



# Apache Cassandra™ 2.1

## Documentation

July 10, 2015

**Apache, Apache Cassandra, Apache Hadoop, Hadoop and the eye logo are trademarks of the Apache Software Foundation**

# Contents

<b>About Apache Cassandra.....</b>	<b>9</b>
<b>What's new in Cassandra 2.1.....</b>	<b>11</b>
<b>CQL.....</b>	<b>12</b>
<b>Understanding the architecture.....</b>	<b>13</b>
Architecture in brief.....	13
Internode communications (gossip).....	15
Failure detection and recovery.....	15
Data distribution and replication.....	16
Consistent hashing.....	16
Virtual nodes.....	17
Data replication.....	18
Partitioners.....	19
Murmur3Partitioner.....	20
RandomPartitioner.....	20
ByteOrderedPartitioner.....	21
Snitches.....	21
Dynamic snitching.....	21
SimpleSnitch.....	22
RackInferringSnitch.....	22
PropertyFileSnitch.....	22
GossipingPropertyFileSnitch.....	23
Ec2Snitch.....	23
Ec2MultiRegionSnitch.....	24
GoogleCloudSnitch.....	26
CloudstackSnitch.....	27
Client requests.....	27
<b>Planning a cluster deployment.....</b>	<b>28</b>
Selecting hardware for enterprise implementations.....	28
Planning an Amazon EC2 cluster.....	31
Calculating usable disk capacity.....	32
Calculating user data size.....	33
Anti-patterns in Cassandra.....	34
<b>Installing.....</b>	<b>37</b>
Installing on RHEL-based systems.....	37
Installing on Debian-based systems.....	38
Installing the binary tarball.....	39
Installing on Windows systems.....	40
Installing prior releases.....	41
Uninstalling Cassandra.....	41
Installing on cloud providers.....	42

Installing on Amazon EC2.....	42
Installing on GoGrid.....	50
Installing Oracle JRE.....	52
Installing the JRE on RHEL-based systems.....	52
Installing the JRE on Debian-based systems.....	53
Recommended production settings.....	54
<b>Initializing a cluster.....</b>	<b>57</b>
Initializing a multiple node cluster (single data center).....	57
Initializing a multiple node cluster (multiple data centers).....	59
<b>Security.....</b>	<b>63</b>
Securing Cassandra.....	63
SSL encryption.....	63
Client-to-node encryption.....	63
Node-to-node encryption.....	64
Using cqlsh with SSL encryption.....	65
Preparing server certificates.....	66
Internal authentication.....	67
Internal authentication.....	67
Configuring authentication.....	67
Logging in using cqlsh.....	68
Internal authorization.....	68
Object permissions.....	69
Configuring internal authorization.....	69
Configuring firewall port access.....	70
Enabling JMX authentication.....	71
<b>Database internals.....</b>	<b>73</b>
Storage engine.....	73
Separate table directories.....	73
Cassandra storage basics.....	73
The write path to compaction.....	74
How Cassandra stores indexes.....	76
About index updates.....	77
The write path of an update.....	77
About deletes.....	77
About hinted handoff writes.....	77
Reads.....	80
About reads.....	80
How off-heap components affect reads.....	81
Reading from a partition.....	82
How write patterns affect reads.....	82
How the row cache affects reads.....	82
About transactions and concurrency control.....	82
Atomicity.....	83
Consistency.....	83
Isolation.....	83
Durability.....	84
Lightweight transactions.....	84
Data consistency.....	85
About data consistency.....	85
About built-in consistency repair features.....	85

Configuring data consistency.....	85
Read requests.....	89
Write requests.....	93
<b>Configuration.....</b>	<b>95</b>
cassandra.yaml configuration file.....	95
Configuring gossip settings.....	111
Configuring the heap dump directory.....	112
Configuring virtual nodes.....	113
Enabling virtual nodes on a new cluster.....	113
Enabling virtual nodes on an existing production cluster.....	113
Using multiple network interfaces.....	114
Configuring logging.....	116
Commit log archive configuration.....	118
Generating tokens.....	119
Hadoop support.....	120
<b>Operations.....</b>	<b>123</b>
Monitoring Cassandra.....	123
Monitoring a Cassandra cluster.....	123
Tuning Bloom filters.....	128
Data caching.....	128
Configuring data caches.....	128
Monitoring and adjusting caching.....	131
Configuring memtable throughput.....	132
Configuring compaction.....	132
Compression.....	133
When to compress data.....	134
Configuring compression.....	134
Testing compaction and compression.....	135
Tuning Java resources.....	135
Purging gossip state on a node.....	137
Repairing nodes.....	138
Adding or removing nodes, data centers, or clusters.....	142
Adding nodes to an existing cluster.....	142
Adding a data center to a cluster.....	144
Replacing a dead node or dead seed node.....	145
Replacing a running node.....	147
Moving a node from one rack to another.....	148
Decommissioning a data center.....	148
Removing a node.....	148
Switching snitches.....	149
Edge cases for transitioning or migrating a cluster.....	150
Adding or replacing single-token nodes.....	151
<b>Backing up and restoring data.....</b>	<b>154</b>
About snapshots.....	154
Taking a snapshot.....	154
Deleting snapshot files.....	155
Enabling incremental backups.....	155
Restoring from a snapshot.....	156
Node restart method.....	157
Restoring a snapshot into a new cluster.....	157

Recovering using JBOD.....	158
<b>Cassandra tools.....</b>	<b>160</b>
The nodetool utility.....	160
cfhistograms.....	160
cfstats.....	161
cleanup.....	167
clearsnapshot.....	168
compact.....	168
compactionhistory.....	169
compactionstats.....	171
decommission.....	172
describecluster.....	172
describing.....	173
disableautocompaction.....	175
disablebackup.....	175
disablebinary.....	176
disablegossip.....	176
disablehandoff.....	177
disablethrift.....	177
drain.....	178
enableautocompaction.....	179
enablebackup.....	179
enablebinary.....	180
enablegossip.....	180
enablehandoff.....	181
enablethrift.....	181
flush.....	181
getcompactionthreshold.....	182
getendpoints.....	183
getlogginglevels.....	183
getsstables.....	184
getstreamthroughput.....	184
gossipinfo.....	185
help.....	185
info.....	186
invalidatekeycache.....	187
invalidaterowcache.....	187
join.....	188
listsnapshots.....	188
move.....	189
netstats.....	190
pausehandoff.....	191
proxyhistograms.....	191
rangekeysample.....	192
rebuild.....	193
rebuild_index.....	193
refresh.....	194
reloadtriggers.....	194
removenode.....	195
repair.....	196
resetlocalschema.....	198
resumehandoff.....	199
ring.....	200
scrub.....	201

setcachecapacity.....	202
setcachekeystosave.....	202
setcompactionthreshold.....	203
setcompactionthroughput.....	204
sethintedhandoffthrottlekb.....	205
setlogginglevel.....	205
setstreamthroughput.....	206
settraceprobability.....	207
snapshot.....	208
status.....	210
statusbackup.....	211
statusbinary.....	212
statusgossip.....	212
statushandoff.....	213
statusthrift.....	213
stop.....	214
stopdaemon.....	214
tpstats.....	215
truncatehints.....	219
upgradesstables.....	219
version.....	220
Cassandra bulk loader (sstableloader).....	221
The cassandra utility.....	223
The cassandra-stress tool.....	226
Using the Daemon Mode.....	230
Interpreting the output of cassandra-stress.....	231
The sstables scrub utility.....	232
The sstablesplit utility.....	233
The sstablekeys utility.....	234
The sstableupgrade tool.....	234
<b>References.....</b>	<b>236</b>
Starting and stopping Cassandra.....	236
Starting Cassandra as a service.....	236
Starting Cassandra as a stand-alone process.....	236
Stopping Cassandra as a service.....	236
Stopping Cassandra as a stand-alone process.....	237
Clearing the data as a service.....	237
Clearing the data as a stand-alone process.....	237
Install locations.....	238
Tarball installation directories.....	238
Package installation directories.....	238
Cassandra include file.....	239
Cassandra-CLI utility (deprecated).....	239
Table attributes.....	240
<b>Moving data to/from other databases.....</b>	<b>243</b>
<b>Troubleshooting.....</b>	<b>244</b>
Peculiar Linux kernel performance problem on NUMA systems.....	244
Reads are getting slower while writes are still fast.....	244
Nodes seem to freeze after some period of time.....	244
Nodes are dying with OOM errors.....	245

## Contents

Nodetool or JMX connections failing on remote nodes.....	245
Handling schema disagreements.....	245
View of ring differs between some nodes.....	246
Java reports an error saying there are too many open files.....	246
Insufficient user resource limits errors.....	246
Cannot initialize class org.xerial.snappy.Snappy.....	248
Firewall idle connection timeout causing nodes to lose communication.....	248
<b>Release notes.....</b>	<b>250</b>
<b>Using the docs.....</b>	<b>252</b>



## About Apache Cassandra

Documentation for developers and administrators on installing, configuring, and using the features and capabilities of Apache Cassandra scalable open source NoSQL database.

Apache Cassandra™ is a massively scalable open source NoSQL database. Cassandra is perfect for managing large amounts of structured, semi-structured, and unstructured data across multiple data centers and the cloud. Cassandra delivers continuous availability, linear scalability, and operational simplicity across many commodity servers with no single point of failure, along with a powerful dynamic data model designed for maximum flexibility and fast response times.

### How does Cassandra work?

Cassandra's built-for-scale architecture means that it is capable of handling petabytes of information and thousands of concurrent users/operations per second.

<b>Cassandra is a partitioned row store database</b>	Cassandra's architecture allows any <b>authorized user</b> to connect to any node in any data center and access data using the CQL language. For ease of use, CQL uses a similar syntax to SQL. The most basic way to interact with Cassandra is using the CQL shell, <b>cqlsh</b> . Using <b>cqlsh</b> , you can create keyspaces and tables, insert and query tables, plus much more. If you prefer a graphical tool, you can use <b>DataStax DevCenter</b> . For production, DataStax supplies a number <b>drivers</b> so that CQL statements can be passed from client to cluster and back. Other administrative tasks can be accomplished using <b>OpsCenter</b> .
<b>Automatic data distribution</b>	Cassandra provides automatic data distribution across all nodes that participate in a <i>ring</i> or database cluster. There is nothing programmatic that a developer or administrator needs to do or code to distribute data across a cluster because data is transparently partitioned across all nodes in a cluster.
<b>Built-in and customizable replication</b>	Cassandra also provides built-in and customizable replication, which stores redundant copies of data across nodes that participate in a Cassandra ring. This means that if any node in a cluster goes down, one or more copies of that node's data is available on other machines in the cluster. Replication can be configured to work across one data center, many data centers, and multiple cloud availability zones.
<b>Cassandra supplies linear scalability</b>	Cassandra supplies linear scalability, meaning that capacity may be easily added simply by adding new nodes online. For example, if 2 nodes can handle 100,000 transactions per second, 4 nodes will support 200,000 transactions/sec and 8 nodes will tackle 400,000 transactions/sec:

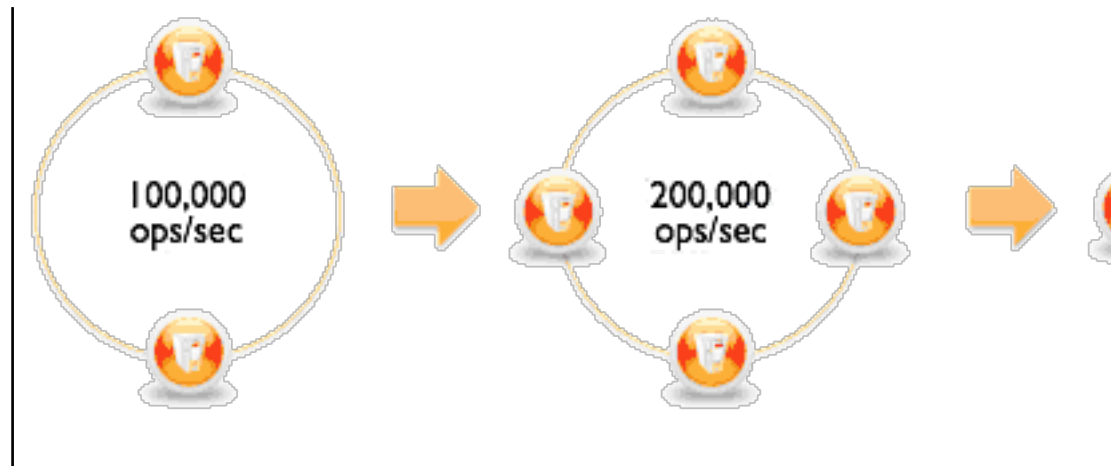

## What's new in Cassandra 2.1

An overview of new features in Cassandra.

New features:

- [User-defined types](#)
- [Collection indexes](#)
- Better [implementation of counters](#) that makes them safer, simpler, and typically faster
- New [listsnapshots](#) and [reloadtriggers](#) nodetool commands
- Improved metrics reporting through the use of the metrics-core library

Performance improvements:

- [Faster reads and writes](#) than previous releases
- [Improved row cache](#)
- [Reduced heap](#) used by memtables
- New [counters implementation](#)

Compaction and repair improvements:

- [Post-compaction read performance](#)
- A configurable percentage of cold SSTables can be ignored
- [Incremental node repair](#)

Other notable changes:

- [Improved Hadoop support](#)
- [Unique table IDs](#)
- [Improved logging](#) using logback
- New [configuration options](#) for allocating and managing memtable memory
- [Improvements to bootstrapping](#) a node that ensure data consistency
- Bundled JNA
- A number of other [CQL and cqlsh](#) changes

[Release notes](#) cover key changes in Cassandra 2.1. For a detailed list of changes, see the [change log](#).

# CQL

Cassandra Query Language (CQL) is the default and primary interface into the Cassandra DBMS.

Cassandra Query Language (CQL) is the default and primary interface into the Cassandra DBMS. Using CQL is similar to using SQL (Structured Query Language). CQL and SQL share the same abstract idea of a table constructed of columns and rows. The main difference from SQL is that Cassandra does not support joins or subqueries. Instead, Cassandra emphasizes denormalization through CQL features like [collections and clustering](#) specified at the schema level.

CQL is the recommended way to interact with Cassandra. Performance and the simplicity of reading and using CQL is an advantage of modern Cassandra over older Cassandra APIs.

The [CQL documentation](#) contains a data modeling section, examples, and command reference. The [cqlsh utility](#) for using CQL interactively on the command line is also covered.

# Understanding the architecture

Important topics for understanding Cassandra.

## Architecture in brief

Essential information for understanding and using Cassandra.

Cassandra is designed to handle big data workloads across multiple nodes with no single point of failure. Its architecture is based on the understanding that system and hardware failures can and do occur. Cassandra addresses the problem of failures by employing a peer-to-peer distributed system across homogeneous nodes where data is distributed among all nodes in the cluster. Each node exchanges information across the cluster every second. A sequentially written commit log on each node captures write activity to ensure data durability. Data is then indexed and written to an in-memory structure, called a memtable, which resembles a write-back cache. Once the memory structure is full, the data is written to disk in an **SSTable** data file. All writes are automatically partitioned and replicated throughout the cluster. Using a process called **compaction** Cassandra periodically consolidates SSTables, discarding obsolete data and **tombstones** (an indicator that data was deleted).

Cassandra is a row-oriented database. Cassandra's architecture allows any **authorized user** to connect to any node in any data center and access data using the CQL language. For ease of use, CQL uses a similar syntax to SQL. From the CQL perspective the database consists of tables. Typically, a cluster has one keyspace per application. Developers can access CQL through `cqlsh` as well as via drivers for application languages.

Client read or write requests can be sent to any node in the cluster. When a client connects to a node with a request, that node serves as the **coordinator** for that particular client operation. The coordinator acts as a proxy between the client application and the nodes that own the data being requested. The coordinator determines which nodes in the ring should get the request based on how the cluster is configured. For more information, see **Client requests**.

### Key structures

- Node
 

Where you store your data. It is the basic infrastructure component of Cassandra.
- Data center
 

A collection of related nodes. A data center can be a physical data center or virtual data center. Different workloads should use separate data centers, either physical or virtual. Replication is set by data center. Using separate data centers prevents Cassandra transactions from being impacted by other workloads and keeps requests close to each other for lower latency. Depending on the replication factor, data can be written to multiple data centers. However, data centers should never span physical locations.
- Cluster
 

A cluster contains one or more data centers. It can span physical locations.
- Commit log
 

All data is written first to the commit log for durability. After all its data has been flushed to SSTables, it can be archived, deleted, or recycled.
- Table
 

A collection of ordered columns fetched by row. A row consists of columns and have a primary key. The first part of the key is a column name.
- SSTable

## Understanding the architecture

A sorted string table (SSTable) is an immutable data file to which Cassandra writes memtables periodically. SSTables are append only and stored on disk sequentially and maintained for each Cassandra table.

### Key components for configuring Cassandra

- **Gossip**

A peer-to-peer communication protocol to discover and share location and state information about the other nodes in a Cassandra cluster. Gossip information is also persisted locally by each node to use immediately when a node restarts.

- **Partitioner**

A partitioner determines how to distribute the data across the nodes in the cluster and which node to place the first copy of data on. Basically, a partitioner is a hash function for computing the token of a partition key. Each row of data is uniquely identified by a partition key and distributed across the cluster by the value of the token. The **Murmur3Partitioner** is the default partitioning strategy for new Cassandra clusters and the right choice for new clusters in almost all cases.

You must set the partitioner and assign the node a **num\_tokens** value for each node. The number of tokens you assign depends on the **hardware capabilities** of the system. If not using virtual nodes (vnodes), use the **initial\_token** setting instead.

- **Replication factor**

The total number of replicas across the cluster. A replication factor of 1 means that there is only one copy of each row on one node. A replication factor of 2 means two copies of each row, where each copy is on a different node. All replicas are equally important; there is no primary or master replica. You define the replication factor for each data center. Generally you should set the replication strategy greater than one, but no more than the number of nodes in the cluster.

- **Replica placement strategy**

Cassandra stores copies (replicas) of data on multiple nodes to ensure reliability and fault tolerance. A replication strategy determines which nodes to place replicas on. The first replica of data is simply the first copy; it is not unique in any sense. The **NetworkTopologyStrategy** is highly recommended for most deployments because it is much easier to expand to multiple data centers when required by future expansion.

When creating a keyspace, you must define the replica placement strategy and the number of replicas you want.

- **Snitch**

A snitch defines groups of machines into data centers and racks (the topology) that the replication strategy uses to place replicas.

You must configure a **snitch** when you create a cluster. All snitches use a dynamic snitch layer, which monitors performance and chooses the best replica for reading. It is enabled by default and recommended for use in most deployments. Configure dynamic snitch thresholds for each node in the `cassandra.yaml` configuration file.

The default **SimpleSnitch** does not recognize data center or rack information. Use it for single-data center deployments or single-zone in public clouds. The **GossipingPropertyFileSnitch** is recommended for production. It defines a node's data center and rack and uses **gossip** for propagating this information to other nodes.

- **The `cassandra.yaml` configuration file**

The main configuration file for setting the initialization properties for a cluster, caching parameters for tables, properties for tuning and resource utilization, timeout settings, client connections, backups, and security.

By default, a node is configured to store the data it manages in a directory set in the `cassandra.yaml` file.

- Package installations: `/var/lib/cassandra`
- Tarball installations: `install_location/data/data`

In a production cluster deployment, you can change the `commitlog-directory` to a different disk drive from the `data_file_directories`.

- **System keyspace table properties**

You set storage configuration attributes on a per-keyspace or per-table basis programmatically or using a client application, such as CQL.

## Internode communications (gossip)

Cassandra uses a protocol called gossip to discover location and state information about the other nodes participating in a Cassandra cluster.

Gossip is a peer-to-peer communication protocol in which nodes periodically exchange state information about themselves and about other nodes they know about. The gossip process runs every second and exchanges state messages with up to three other nodes in the cluster. The nodes exchange information about themselves and about the other nodes that they have gossiped about, so all nodes quickly learn about all other nodes in the cluster. A gossip message has a version associated with it, so that during a gossip exchange, older information is overwritten with the most current state for a particular node.

To prevent problems in gossip communications, use the same list of seed nodes for all nodes in a cluster. This is most critical the first time a node starts up. By default, a node remembers other nodes it has gossiped with between subsequent restarts. The seed node designation has no purpose other than bootstrapping the gossip process for new nodes joining the cluster. Seed nodes are *not* a single point of failure, nor do they have any other special purpose in cluster operations beyond the bootstrapping of nodes.

**Attention:** In multiple data-center clusters, the seed list should include at least one node from each data center (replication group). More than a single seed node per data center is recommended for fault tolerance. Otherwise, gossip has to communicate with another data center when bootstrapping a node. Making every node a seed node is **not** recommended because of increased maintenance and reduced gossip performance. Gossip optimization is not critical, but it is recommended to use a small seed list (approximately three nodes per data center).

## Failure detection and recovery

A method for locally determining from gossip state and history if another node in the system is down or has come back up.

Failure detection is a method for locally determining from gossip state and history if another node in the system is down or has come back up. Cassandra uses this information to avoid routing client requests to unreachable nodes whenever possible. (Cassandra can also avoid routing requests to nodes that are alive, but performing poorly, through the `dynamic snitch`.)

The gossip process tracks state from other nodes both directly (nodes gossiping directly to it) and indirectly (nodes communicated about secondhand, third-hand, and so on). Rather than have a fixed threshold for marking failing nodes, Cassandra uses an accrual detection mechanism to calculate a per-node threshold that takes into account network performance, workload, and historical conditions. During gossip exchanges, every node maintains a sliding window of inter-arrival times of gossip messages from other nodes in the cluster. Configuring the `phi_convict_threshold` property adjusts the sensitivity of the failure detector. Lower values increase the likelihood that an unresponsive node will be marked as down, while higher values decrease the likelihood that transient failures causing node failure. Use the default value for most situations, but increase it to 10 or 12 for Amazon EC2 (due to frequently encountered network congestion). In unstable network environments (such as EC2 at times), raising the value to 10 or 12 helps prevent false failures. Values higher than 12 and lower than 5 are not recommended.

## Understanding the architecture

Node failures can result from various causes such as hardware failures and network outages. Node outages are often transient but can last for extended periods. Because a node outage rarely signifies a permanent departure from the cluster it does not automatically result in permanent removal of the node from the ring. Other nodes will periodically try to re-establish contact with failed nodes to see if they are back up. To permanently change a node's membership in a cluster, administrators must explicitly add or remove nodes from a Cassandra cluster using the [nodetool utility](#) or OpsCenter.

When a node comes back online after an outage, it may have missed writes for the replica data it maintains. Once the failure detector marks a node as down, missed writes are stored by other replicas for a period of time providing [hinted handoff](#) is enabled. If a node is down for longer than [max\\_hint\\_window\\_in\\_ms](#) (3 hours by default), hints are no longer saved. Nodes that die may have stored undelivered hints. Run a repair after recovering a node that has been down for an extended period. Moreover, you should routinely run [nodetool repair](#) on all nodes to ensure they have consistent data.

For more explanation about hint storage, see [Modern hinted handoff](#).

## Data distribution and replication

How data is distributed and factors influencing replication.

In Cassandra, data distribution and replication go together. Data is organized by table and identified by a primary key, which determines which node the data is stored on. Replicas are copies of rows. When data is first written, it is also referred to as a replica.

Factors influencing replication include:

- [Virtual nodes](#): assigns data ownership to physical machines.
- [Partitioner](#): partitions the data across the cluster.
- [Replication strategy](#): determines the replicas for each row of data.
- [Snitch](#): defines the topology information that the replication strategy uses to place replicas.

## Consistent hashing

Consistent hashing allows distribution of data across a cluster to minimize reorganization when nodes are added or removed.

Consistent hashing allows distribution of data across a cluster to minimize reorganization when nodes are added or removed. Consistent hashing partitions data based on the partition key. (For an explanation of partition keys and primary keys, see the [Data modeling example](#) in *CQL for Cassandra 2.0*.)

For example, if you have the following data:

name	age	car	gender
jim	36	camaro	M
carol	37	bmw	F
johnny	12		M
suzy	10		F

Cassandra assigns a hash value to each partition key:

Partition key	Murmur3 hash value
jim	-2245462676723223822
carol	7723358927203680754
johnny	-6723372854036780875



Partition key	Murmur3 hash value
suzy	1168604627387940318

Each node in the cluster is responsible for a range of data based on the hash value:

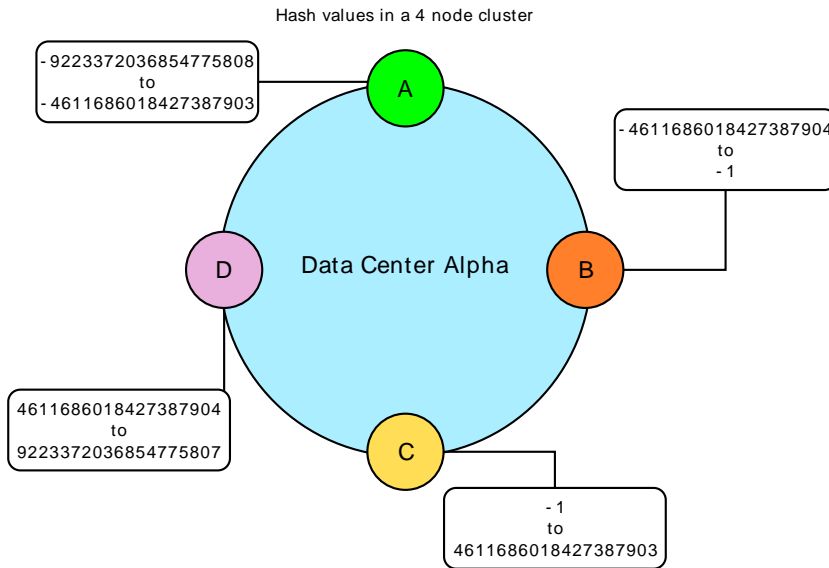

Cassandra places the data on each node according to the value of the partition key and the range that the node is responsible for. For example, in a four node cluster, the data in this example is distributed as follows:

Node	Start range	End range	Partition key	Hash value
A	-9223372036854775808	-4611686018427387903	johnny	-6723372854036780875
B	-4611686018427387904	-1	jim	-2245462676723223822
C	0	4611686018427387903	suzy	1168604627387940318
D	4611686018427387904	9223372036854775807	carol	7723358927203680754

## Virtual nodes

Overview of virtual nodes (vnodes).

Vnodes simplify many tasks in Cassandra:

- You no longer have to calculate and assign tokens to each node.
- Rebalancing a cluster is no longer necessary when adding or removing nodes. When a node joins the cluster, it assumes responsibility for an even portion of data from the other nodes in the cluster. If a node fails, the load is spread evenly across other nodes in the cluster.
- Rebuilding a dead node is faster because it involves every other node in the cluster.
- Improves the use of heterogeneous machines in a cluster. You can assign a proportional number of vnodes to smaller and larger machines.

For more information, see the article [Virtual nodes in Cassandra 1.2](#) and [Enabling virtual nodes on an existing production cluster](#).

To convert an existing cluster to vnodes, see [Enabling virtual nodes on an existing production cluster](#).

## Understanding the architecture

### How data is distributed across a cluster (using virtual nodes)

Vnodes use consistent hashing to distribute data without requiring new token generation and assignment.

Prior to version 1.2, you had to calculate and assign a single **token** to each node in a cluster. Each token determined the node's position in the ring and its portion of data according to its hash value. Starting in version 1.2, Cassandra allows many tokens per node. The new paradigm is called virtual nodes (vnodes). Vnodes allow each node to own a large number of small **partition ranges** distributed throughout the cluster. Vnodes also use consistent hashing to distribute data but using them doesn't require token generation and assignment.

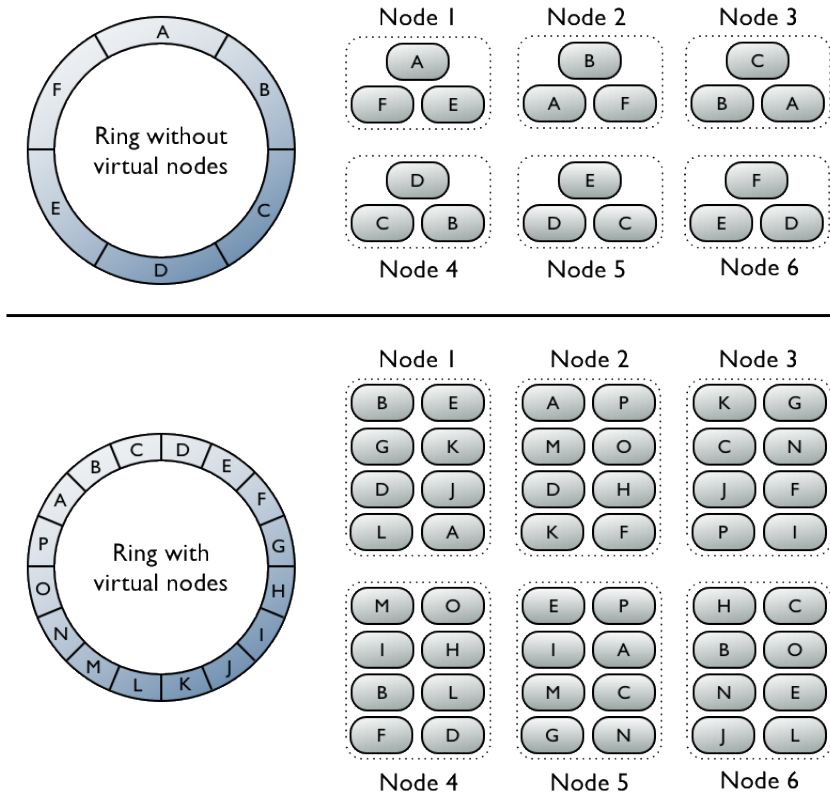

**Figure 1: Virtual vs single-token architecture**

The top portion of the graphic shows a cluster without vnodes. In this paradigm, each node is assigned a single token that represents a location in the ring. Each node stores data determined by mapping the **partition key** to a token value within a range from the previous node to its assigned value. Each node also contains copies of each row from other nodes in the cluster. For example, range E replicates to nodes 5, 6, and 1. Notice that a node owns exactly one contiguous partition range in the ring space.

The bottom portion of the graphic shows a ring with vnodes. Within a cluster, virtual nodes are randomly selected and non-contiguous. The placement of a row is determined by the hash of the partition key within many smaller partition ranges belonging to each node.

### Data replication

Cassandra stores replicas on multiple nodes to ensure reliability and fault tolerance. A replication strategy determines the nodes where replicas are placed.

Cassandra stores replicas on multiple nodes to ensure reliability and fault tolerance. A replication strategy determines the nodes where replicas are placed. The total number of replicas across the cluster is referred to as the replication factor. A replication factor of 1 means that there is only one copy of each row on one node. A replication factor of 2 means two copies of each row, where each copy is on a different node. All replicas are equally important; there is no primary or master replica. As a general rule, the replication factor

should not exceed the number of nodes in the cluster. However, you can increase the replication factor and then add the desired number of nodes later.

Two replication strategies are available:

- `SimpleStrategy`: Use for a single **data center** only. If you ever intend more than one data center, use the `NetworkTopologyStrategy`.
- `NetworkTopologyStrategy`: Highly recommended for most deployments because it is much easier to expand to multiple data centers when required by future expansion.

### SimpleStrategy

Use only for a single data center. `SimpleStrategy` places the first replica on a node determined by the partitioner. Additional replicas are placed on the next nodes clockwise in the ring without considering topology (rack or data center location).

### NetworkTopologyStrategy

Use `NetworkTopologyStrategy` when you have (or plan to have) your cluster deployed across multiple data centers. This strategy specifies how many replicas you want in each data center.

`NetworkTopologyStrategy` places replicas in the same data center by walking the ring clockwise until reaching the first node in another rack. `NetworkTopologyStrategy` attempts to place replicas on distinct racks because nodes in the same rack (or similar physical grouping) often fail at the same time due to power, cooling, or network issues.

When deciding how many replicas to configure in each data center, the two primary considerations are (1) being able to satisfy reads locally, without incurring cross data-center latency, and (2) failure scenarios. The two most common ways to configure multiple data center clusters are:

- Two replicas in each data center: This configuration tolerates the failure of a single node per replication group and still allows local reads at a consistency level of `ONE`.
- Three replicas in each data center: This configuration tolerates either the failure of a one node per replication group at a strong consistency level of `LOCAL_QUORUM` or multiple node failures per data center using consistency level `ONE`.

Asymmetrical replication groupings are also possible. For example, you can have three replicas in one data center to serve real-time application requests and use a single replica elsewhere for running analytics.

### Choosing keyspace replication options

Options to set replication strategy.

To set the replication strategy for a keyspace, see [CREATE KEYSPACE](#).

When you use `NetworkTopologyStrategy`, during creation of the keyspace, you use the data center names defined for the **snitch** used by the cluster. To place replicas in the correct location, Cassandra requires a keyspace definition that uses the snitch-configured data center names. For example, if the cluster uses the `PropertyFileSnitch`, create the keyspace using the user-defined data center and rack names in the `cassandra-topologies.properties` file. If the cluster uses the `Ec2Snitch`, create the keyspace using EC2 data center and rack names. If the cluster uses the `GoogleCloudSnitch`, create the keyspace using GoogleCloud data center and rack names.

## Partitioners

A partitioner determines how data is distributed across the nodes in the cluster (including replicas).

A partitioner determines how data is distributed across the nodes in the cluster (including replicas). Basically, a partitioner is a function for deriving a token representing a row from its partition key, typically by hashing. Each row of data is then distributed across the cluster by the value of the token.

Both the `Murmur3Partitioner` and `RandomPartitioner` use tokens to help assign equal portions of data to each node and evenly distribute data from all the tables throughout the ring or other grouping, such as a keyspace. This is true even if the tables use different **partition keys**, such as usernames or

## Understanding the architecture

timestamps. Moreover, the read and write requests to the cluster are also evenly distributed and load balancing is simplified because each part of the hash range receives an equal number of rows on average. For more detailed information, see [Consistent hashing](#).

Cassandra offers the following partitioners:

- `Murmur3Partitioner` (default): uniformly distributes data across the cluster based on `MurmurHash` hash values.
- `RandomPartitioner`: uniformly distributes data across the cluster based on MD5 hash values.
- `ByteOrderedPartitioner`: keeps an ordered distribution of data lexically by key bytes

The `Murmur3Partitioner` is the default partitioning strategy for new Cassandra clusters and the right choice for new clusters in almost all cases.

Set the partitioner in the `cassandra.yaml` file:

- `Murmur3Partitioner`: `org.apache.cassandra.dht.Murmur3Partitioner`
- `RandomPartitioner`: `org.apache.cassandra.dht.RandomPartitioner`
- `ByteOrderedPartitioner`: `org.apache.cassandra.dht.ByteOrderedPartitioner`

**Note:** If using virtual nodes (vnodes), you do **not** need to calculate the tokens. If not using vnodes, you **must** calculate the tokens to assign to the `initial_token` parameter in the `cassandra.yaml` file. See [Generating tokens](#) and use the method for the type of partitioner you are using.

The location of the `cassandra.yaml` file depends on the type of installation:

Package installations	<code>/etc/cassandra/cassandra.yaml</code>
Tarball installations	<code>install_location/resources/cassandra/conf/cassandra.yaml</code>

### Murmur3Partitioner

The `Murmur3Partitioner` provides faster hashing and improved performance than the previous default partitioner.

The `Murmur3Partitioner` provides faster hashing and improved performance than the previous default partitioner (`RandomPartitioner`). You can only use `Murmur3Partitioner` for new clusters; you cannot change the partitioner in existing clusters. The `Murmur3Partitioner` uses the `MurmurHash` function. This hashing function creates a 64-bit hash value of the partition key. The possible range of hash values is from  $-2^{63}$  to  $+2^{63}-1$ .

When using the `Murmur3Partitioner`, you can page through all rows using the `token function` in a CQL query.

### RandomPartitioner

The default partitioner prior to Cassandra 1.2.

The `RandomPartitioner` was the default partitioner prior to Cassandra 1.2. It is included for backwards compatibility. You can use it in later versions of Cassandra, even when using virtual nodes (vnodes). However, if you don't use vnodes, you must calculate the tokens, as described in [Generating tokens](#).

The `RandomPartitioner` distributes data evenly across the nodes using an MD5 hash value of the row key. The possible range of hash values is from 0 to  $2^{127}-1$ .

When using the `RandomPartitioner`, you can page through all rows using the `token function` in a CQL query.

## ByteOrderedPartitioner

Cassandra provides this partitioner for ordered partitioning. It is included for backwards compatibility.

Cassandra provides the `ByteOrderedPartitioner` for ordered partitioning. It is included for backwards compatibility. This partitioner orders rows lexically by key bytes. You calculate tokens by looking at the actual values of your partition key data and using a hexadecimal representation of the leading character(s) in a key. For example, if you wanted to partition rows alphabetically, you could assign an A token using its hexadecimal representation of 41.

Using the ordered partitioner allows ordered scans by primary key. This means you can scan rows as though you were moving a cursor through a traditional index. For example, if your application has user names as the partition key, you can scan rows for users whose names fall between Jake and Joe. This type of query is not possible using randomly partitioned partition keys because the keys are stored in the order of their MD5 hash (not sequentially).

Although having the capability to do range scans on rows sounds like a desirable feature of ordered partitioners, there are ways to achieve the same functionality using [table indexes](#).

Using an ordered partitioner is not recommended for the following reasons:

### Difficult load balancing

More administrative overhead is required to load balance the cluster. An ordered partitioner requires administrators to manually calculate [partition ranges](#) based on their estimates of the partition key distribution. In practice, this requires actively moving node tokens around to accommodate the actual distribution of data once it is loaded.

### Sequential writes can cause hot spots

If your application tends to write or update a sequential block of rows at a time, then the writes are not be distributed across the cluster; they all go to one node. This is frequently a problem for applications dealing with timestamped data.

### Uneven load balancing for multiple tables

If your application has multiple tables, chances are that those tables have different row keys and different distributions of data. An ordered partitioner that is balanced for one table may cause hot spots and uneven distribution for another table in the same cluster.

## Snitches

A snitch determines which data centers and racks nodes belong to.

A snitch determines which data centers and racks nodes belong to. They inform Cassandra about the network topology so that requests are routed efficiently and allows Cassandra to distribute replicas by grouping machines into data centers and racks. Specifically, the replication strategy places the replicas based on the information provided by the new snitch. All nodes must return to the same rack and data center. Cassandra does its best not to have more than one replica on the same rack (which is not necessarily a physical location).

**Note:** If you change snitches, you may need to perform additional steps because the snitch affects where replicas are placed. See [Switching snitches](#).

## Dynamic snitching

Monitors the performance of reads from the various replicas and chooses the best replica based on this history.

By default, all snitches also use a dynamic snitch layer that monitors read latency and, when possible, routes requests away from poorly-performing nodes. The dynamic snitch is enabled by default and is recommended for use in most deployments. For information on how this works, see [Dynamic snitching in Cassandra: past, present, and future](#). Configure dynamic snitch thresholds for each node in the `cassandra.yaml` configuration file.

## Understanding the architecture

For more information, see the properties listed under [Failure detection and recovery](#).

The location of the `cassandra.yaml` file depends on the type of installation:

Package installations	<code>/etc/cassandra/cassandra.yaml</code>
Tarball installations	<code>install_location/resources/cassandra/conf/cassandra.yaml</code>

## SimpleSnitch

The SimpleSnitch is used only for single-data center deployments.

The SimpleSnitch (default) is used only for single-data center deployments. It does not recognize data center or rack information and can be used only for single-data center deployments or single-zone in public clouds. It treats strategy order as proximity, which can improve cache locality when disabling read repair.

Using a SimpleSnitch, you [define the keyspace](#) to use SimpleStrategy and specify a replication factor.

## RackInferringSnitch

Determines the location of nodes by rack and data center corresponding to the IP addresses.

The RackInferringSnitch determines the proximity of nodes by rack and data center, which are assumed to correspond to the 3rd and 2nd octet of the node's IP address, respectively. This snitch is best used as an example for writing a custom snitch class (unless this happens to match your deployment conventions).

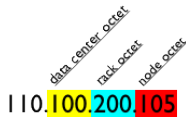

## PropertyFileSnitch

Determines the location of nodes by rack and data center.

### About this task

This snitch determines proximity is determined by rack and data center. It uses the network details located in the `cassandra-topology.properties` file. When using this snitch, you can define your data center names to be whatever you want. Make sure that the data center names correlate to the name of your data centers in the [keyspace definition](#). Every node in the cluster should be described in the `cassandra-topology.properties` file, and this file should be exactly the same on every node in the cluster.

The location of the `cassandra-topology.properties` file depends on the type of installation:

Package installations	<code>/etc/cassandra/cassandra-topology.properties</code>
Tarball installations	<code>install_location/conf/cassandra-topology.properties</code>

## Procedure

If you had non-uniform IPs and two physical data centers with two racks in each, and a third logical data center for replicating analytics data, the `cassandra-topology.properties` file might look like this:

**Note:** Data center and rack names are case-sensitive.

```
# Data Center One
```

```

175.56.12.105=DC1:RAC1
175.50.13.200=DC1:RAC1
175.54.35.197=DC1:RAC1

120.53.24.101=DC1:RAC2
120.55.16.200=DC1:RAC2
120.57.102.103=DC1:RAC2

# Data Center Two

110.56.12.120=DC2:RAC1
110.50.13.201=DC2:RAC1
110.54.35.184=DC2:RAC1

50.33.23.120=DC2:RAC2
50.45.14.220=DC2:RAC2
50.17.10.203=DC2:RAC2

# Analytics Replication Group

172.106.12.120=DC3:RAC1
172.106.12.121=DC3:RAC1
172.106.12.122=DC3:RAC1

# default for unknown nodes default =DC3:RAC1

```

## GossipingPropertyFileSnitch

Automatically updates all nodes using gossip when adding new nodes and is recommended for production.

This snitch is recommended for production. It uses rack and data center information for the local node defined in the `cassandra-rackdc.properties` file and propagates this information to other nodes via gossip.

The `cassandra-rackdc.properties` file defines the default data center and rack used by this snitch:

**Note:** Data center and rack names are case-sensitive.

```

dc=DC1
rack=RAC1

```

To save bandwidth, add the `prefer_local=true` option. This option tells Cassandra to use the local IP address when communication is not across different data centers.

To allow migration from the PropertyFileSnitch, the GossipingPropertyFileSnitch uses the `cassandra-topology.properties` file when present.

The location of the `cassandra-rackdc.properties` file depends on the type of installation:

Package installations	<code>/etc/cassandra/cassandra-rackdc.properties</code>
Tarball installations	<code>install_location/conf/cassandra-rackdc.properties</code>

## Ec2Snitch

Use the Ec2Snitch with Amazon EC2 in a single region.

Use the Ec2Snitch for simple cluster deployments on Amazon EC2 where all nodes in the cluster are within a single region.



## Understanding the architecture

In EC2 deployments, the region name is treated as the data center name and availability zones are treated as racks within a data center. For example, if a node is in the us-east-1 region, us-east is the data center name and 1 is the rack location. (Racks are important for distributing replicas, but not for data center naming.) Because private IPs are used, this snitch does not work across multiple regions.

If you are using only a single data center, you do not need to specify any properties.

If you need multiple data centers, set the `dc_suffix` options in the `cassandra-rackdc.properties` file. Any other lines are ignored.

For example, for each node within the us-east region, specify the data center in its `cassandra-rackdc.properties` file:

**Note:** Data center names are case-sensitive.

- **node0**  
`dc_suffix=_1_cassandra`
- **node1**  
`dc_suffix=_1_cassandra`
- **node2**  
`dc_suffix=_1_cassandra`
- **node3**  
`dc_suffix=_1_cassandra`
- **node4**  
`dc_suffix=_1_analytics`
- **node5**  
`dc_suffix=_1_search`

This results in three data centers for the region:

```
us-east_1_cassandra
us-east_1_analytics
us-east_1_search
```

**Note:** The data center naming convention in this example is based on the workload. You can use other conventions, such as DC1, DC2 or 100, 200.

### Keyspace strategy options

When defining your **keyspace strategy options**, use the EC2 region name, such as us-east, as your data center name.

The location of the `cassandra-rackdc.properties` file depends on the type of installation:

Package installations	<code>/etc/cassandra/cassandra-rackdc.properties</code>
Tarball installations	<code>install_location/conf/cassandra-rackdc.properties</code>

## Ec2MultiRegionSnitch

Use the `Ec2MultiRegionSnitch` for deployments on Amazon EC2 where the cluster spans multiple regions.

Use the `Ec2MultiRegionSnitch` for deployments on Amazon EC2 where the cluster spans multiple regions.

You must configure settings in both the `cassandra.yaml` file and the property file (`cassandra-rackdc.properties`) used by the `Ec2MultiRegionSnitch`.



### Configuring cassandra.yaml for cross-region communication

The Ec2MultiRegionSnitch uses public IP designated in the `broadcast_address` to allow cross-region connectivity. Configure each node as follows:

1. In the `cassandra.yaml`, set the `listen_address` to the *private* IP address of the node, and the `broadcast_address` to the *public* IP address of the node.

This allows Cassandra nodes in one EC2 region to bind to nodes in another region, thus enabling multiple data center support. For intra-region traffic, Cassandra switches to the private IP after establishing a connection.

2. Set the addresses of the seed nodes in the `cassandra.yaml` file to that of the *public* IP. Private IP are not routable between networks. For example:

```
seeds: 50.34.16.33, 60.247.70.52
```

To find the public IP address, from each of the seed nodes in EC2:

```
$ curl http://instance-data/latest/meta-data/public-ipv4
```

**Note:** Do not make all nodes seeds, see [Internode communications \(gossip\)](#).

3. Be sure that the `storage_port` or `ssl_storage_port` is open on the public IP firewall.

### Configuring the snitch for cross-region communication

In EC2 deployments, the region name is treated as the data center name and availability zones are treated as racks within a data center. For example, if a node is in the `us-east-1` region, `us-east` is the data center name and `1` is the rack location. (Racks are important for distributing replicas, but not for data center naming.)

For each node, specify its data center in the `cassandra-rackdc.properties`. The `dc_suffix` option defines the data centers used by the snitch. Any other lines are ignored.

In the example below, there are two Cassandra data centers and each data center is named for its workload. The data center naming convention in this example is based on the workload. You can use other conventions, such as `DC1`, `DC2` or `100`, `200`. (Data center names are case-sensitive.)

Region: us-east	Region: us-west
Node and data center: <ul style="list-style-type: none"> <li>• <b>node0</b> dc_suffix=_1_cassandra</li> <li>• <b>node1</b> dc_suffix=_1_cassandra</li> <li>• <b>node2</b> dc_suffix=_2_cassandra</li> <li>• <b>node3</b> dc_suffix=_2_cassandra</li> <li>• <b>node4</b> dc_suffix=_1_analytics</li> <li>• <b>node5</b> dc_suffix=_1_search</li> </ul> This results in four us-east data centers:  us-east_1_cassandra	Node and data center: <ul style="list-style-type: none"> <li>• <b>node0</b> dc_suffix=_1_cassandra</li> <li>• <b>node1</b> dc_suffix=_1_cassandra</li> <li>• <b>node2</b> dc_suffix=_2_cassandra</li> <li>• <b>node3</b> dc_suffix=_2_cassandra</li> <li>• <b>node4</b> dc_suffix=_1_analytics</li> <li>• <b>node5</b> dc_suffix=_1_search</li> </ul> This results in four us-west data centers:  us-west_1_cassandra

## Understanding the architecture

Region: us-east	Region: us-west
us-east_2_cassandra us-east_1_analytics us-east_1_search	us-west_2_cassandra us-west_1_analytics us-west_1_search

### Keyspace strategy options

When defining your **keyspace strategy options**, use the EC2 region name, such as us-east, as your data center name.

The location of the `cassandra-rackdc.properties` file depends on the type of installation:

Package installations	<code>/etc/cassandra/cassandra-rackdc.properties</code>
Tarball installations	<code>install_location/conf/cassandra-rackdc.properties</code>

The location of the `cassandra.yaml` file depends on the type of installation:

Package installations	<code>/etc/cassandra/cassandra.yaml</code>
Tarball installations	<code>install_location/resources/cassandra/conf/cassandra.yaml</code>

## GoogleCloudSnitch

Use the GoogleCloudSnitch for Cassandra deployments on Google Cloud Platform across one or more regions.

Use the GoogleCloudSnitch for Cassandra deployments on **Google Cloud Platform** across one or more regions. The region is treated as a data center and the availability zones are treated as racks within the data center. All communication occurs over private IP addresses within the same logical network.

The region name is treated as the data center name and zones are treated as racks within a data center. For example, if a node is in the us-central1-a region, us-central1 is the data center name and a is the rack location. (Racks are important for distributing replicas, but not for data center naming.) This snitch can work across multiple regions without additional configuration.

If you are using only a single data center, you do not need to specify any properties.

If you need multiple data centers, set the `dc_suffix` options in the `cassandra-rackdc.properties` file. Any other lines are ignored.

For example, for each node within the us-central1 region, specify the data center in its `cassandra-rackdc.properties` file:

**Note:** Data center names are case-sensitive.

- **node0**  
`dc_suffix=_a_cassandra`
- **node1**  
`dc_suffix=_a_cassandra`
- **node2**  
`dc_suffix=_a_cassandra`
- **node3**  
`dc_suffix=_a_cassandra`

- **node4**  
dc\_suffix=\_a\_analytics
- **node5**  
dc\_suffix=\_a\_search

**Note:** Data center and rack names are case-sensitive.

## CloudstackSnitch

Use the CloudstackSnitch for Apache Cloudstack environments.

Use the CloudstackSnitch for **Apache Cloudstack** environments. Because zone naming is free-form in Apache Cloudstack, this snitch uses the widely-used <country> <location> <az> notation.

## Client requests

Client read or write requests can be sent to any node in the cluster because all nodes in Cassandra are peers.

Client read or write requests can be sent to any node in the cluster because all nodes in Cassandra are peers. When a client connects to a node and issues a read or write request, that node serves as the **coordinator** for that particular client operation.

The job of the coordinator is to act as a proxy between the client application and the nodes (or replicas) that own the data being requested. The coordinator determines which nodes in the ring should get the request based on the cluster configured **partitioner** and **replica placement** strategy.

# Planning a cluster deployment

Vital information about successfully deploying a Cassandra cluster.

When planning a Cassandra cluster deployment, you should have a good idea of the initial volume of data you plan to store and a good estimate of your typical application workload. The following topics provide information for planning your cluster:

## Selecting hardware for enterprise implementations

Choosing appropriate hardware depends on selecting the right balance of the following resources: memory, CPU, disk type, number of nodes, and network.

Choosing appropriate hardware depends on selecting the right balance of the following resources: memory, CPU, disk type, number of nodes, and network. [Anti-patterns in Cassandra](#) also contains important information about hardware, particularly SAN storage, NAS devices, and NFS.

**Caution:** Do not use a machine suited for development for load testing or production. Failure may result.

### Memory

The more memory a Cassandra node has, the better read performance. More RAM also allows memory tables (memtables) to hold more recently written data. Larger memtables lead to a fewer number of SSTables being flushed to disk and fewer files to scan during a read. The ideal amount of RAM depends on the anticipated size of your hot data.

For both dedicated hardware and virtual environments:

- Production: 16GB to 64GB; the minimum is 8GB.
- Development in non-loading testing environments: no less than 4GB.
- For setting Java heap space, see [Tuning Java resources](#).

### CPU

Insert-heavy workloads are CPU-bound in Cassandra before becoming memory-bound. (All writes go to the commit log, but Cassandra is so efficient in writing that the CPU is the limiting factor.) Cassandra is highly concurrent and uses as many CPU cores as available:

- Production environments:
  - For dedicated hardware, 8-core CPU processors are the current price-performance sweet spot.
  - For virtual environments, 4 to 8-core CPU processors.
- Development in non-loading testing environments:
  - For dedicated hardware, 2-core CPU processors.
  - For virtual environments, 2-core CPU processors.

### Spinning disks versus Solid State Drives

SSDs are recommended for Cassandra. The NAND Flash chips that power SSDs provide extremely low-latency response times for random reads while supplying ample sequential write performance for compaction operations. In recent years, drive manufacturers have improved overall endurance, usually in conjunction with spare (unexposed) capacity. Additionally, because PBW/DWPD ratings are probabilistic estimates based on worst case scenarios, such as random write workloads, and Cassandra does only large sequential writes, drives significantly exceed their endurance ratings. However, it is important to

plan for drive failures and have spares available. A large variety of SSDs are available on the market from server vendors and third-party drive manufacturers.

For purchasing SSDs, the best recommendation is to make SSD endurance decisions not based on workload, but on how difficult it is to change drives when they fail. Remember, your data is protected because Cassandra replicates data across the cluster. Buying strategies include:

- If drives are quickly available, buy the cheapest drives that provide the performance you want.
- If it is more challenging to swap the drives, consider higher endurance models, possibly starting in the mid range, and then choose replacements of higher or lower endurance based on the failure rates of the initial model chosen.
- Always buy cheap SSDs and keep several spares online and unused in the servers until the initial drives fail. This way you can replace the drives without touching the server.

DataStax customers that need help in determining the most cost-effective option for a given deployment and workload, should contact their Solutions Engineer or Architect.

### Disk space

Disk space depends on usage, so it's important to understand the mechanism. Cassandra writes data to disk when appending data to the **commit log** for durability and when flushing **memtable** to **SSTable** data files for persistent storage. The commit log has a different access pattern (read/writes ratio) than the pattern for accessing data from SSTables. This is more important for spinning disks than for SSDs (solid state drives).

SSTables are periodically compacted. Compaction improves performance by merging and rewriting data and discarding old data. However, depending on the type of **compaction strategy** and size of the compactions, during compaction disk utilization and data directory volume temporarily increases. For this reason, you should leave an adequate amount of free disk space available on a node. For large compactions, leave an adequate amount of free disk space available on a node: 50% (worst case) for **SizeTieredCompactionStrategy** and **DateTieredCompactionStrategy**, and 10% for **LeveledCompactionStrategy**. For more information about compaction, see:

- [Compaction](#)
- [The Apache Cassandra storage engine](#)
- [Leveled Compaction in Apache Cassandra](#)
- [When to Use Leveled Compaction](#)
- [DateTieredCompactionStrategy: Compaction for Time Series Data](#) and [Getting Started with Time Series Data Modeling](#)

For information on calculating disk size, see [Calculating usable disk capacity](#).

### Recommendations:

#### Capacity per node

Most workloads work best with a capacity under 500GB to 1TB per node depending on I/O. Maximum recommended capacity for Cassandra 1.2 and later is 3 to 5TB per node for uncompressed data. For Cassandra 1.1, it is 500 to 800GB per node. Be sure to account for **replication**.

#### Capacity and I/O

When choosing disks, consider both capacity (how much data you plan to store) and I/O (the write/read throughput rate). Some workloads are best served by using less expensive SATA disks and scaling disk capacity and I/O by adding more nodes (with more RAM).

#### Number of disks - SATA

Ideally Cassandra needs at least two disks, one for the commit log and the other for the data directories. At a minimum the commit log should be on its own partition.

#### Commit log disk - SATA

The disk need not be large, but it should be fast enough to receive all of your writes as appends (sequential I/O).

## Planning a cluster deployment

### Commit log disk - SSD

Unlike spinning disks, it's all right to store both commit logs and SSTables on the same mount point.

### Data disks

Use one or more disks and make sure they are large enough for the data volume and fast enough to both satisfy reads that are not cached in memory and to keep up with compaction.

### RAID on data disks

It is generally not necessary to use RAID for the following reasons:

- Data is replicated across the cluster based on the replication factor you've chosen.
- Starting in version 1.2, Cassandra includes a JBOD (Just a bunch of disks) feature to take care of disk management. Because Cassandra properly reacts to a disk failure either by stopping the affected node or by blacklisting the failed drive, you can deploy Cassandra nodes with large disk arrays without the overhead of RAID 10. You can configure Cassandra to stop the affected node or blacklist the drive according to your availability/consistency requirements. You can also [recover a disk using JBOD](#).

### RAID on the commit log disk

Generally RAID is not needed for the commit log disk. Replication adequately prevents data loss. If you need extra redundancy, use RAID 1.

### Extended file systems

DataStax recommends deploying Cassandra on XFS or ext4. On ext2 or ext3, the maximum file size is 2TB even using a 64-bit kernel. On ext4 it is 16TB.

Because Cassandra can use almost half your disk space for a single file when using [SizeTieredCompactionStrategy](#), use XFS when using large disks, particularly if using a 32-bit kernel. XFS file size limits are 16TB max on a 32-bit kernel, and essentially unlimited on 64-bit.

### Number of nodes

Prior to version 1.2, the recommended size of disk space per node was 300 to 500GB. Improvement to Cassandra 1.2, such as JBOD support, virtual nodes (vnodes), off-heap Bloom filters, and parallel leveled compaction (SSD nodes only), allow you to use few machines with multiple terabytes of disk space.

### Network

Since Cassandra is a distributed data store, it puts load on the network to handle read/write requests and replication of data across nodes. Be sure that your network can handle traffic between nodes without bottlenecks. You should bind your interfaces to separate Network Interface Cards (NIC). You can use public or private depending on your requirements.

- Recommended bandwidth is 1000 Mbit/s (gigabit) or greater.
- Thrift/native protocols use the [rpc\\_address](#).
- Cassandra's internal storage protocol uses the [listen\\_address](#).

Cassandra efficiently routes requests to replicas that are geographically closest to the coordinator node and chooses a replica in the same rack if possible; it always chooses replicas located in the same data center over replicas in a remote data center.

### Firewall

If using a firewall, make sure that nodes within a cluster can reach each other. See [Configuring firewall port access](#).

## Planning an Amazon EC2 cluster

Important information for deploying a production Cassandra cluster on Amazon EC2.

Before planning an Amazon EC2 cluster, please see the [User guide](#) in the *Amazon Elastic Compute Cloud Documentation*.

### DataStax AMI deployments

The [DataStax AMI](#) is intended only for a single region and availability zone. For an EC2 cluster that spans multiple regions and availability zones, see [EC2 clusters spanning multiple regions and availability zones](#).

### Use AMIs from trusted sources

Use only AMIs from a trusted source. Random AMI's pose a security risk and may perform slower than expected due to the way the EC2 install is configured. The following are examples of trusted AMIs:

- [Ubuntu Amazon EC2 AMI Locator](#)
- [Debian AmazonEC2Image](#)
- [CentOS-6 images on Amazon's EC2 Cloud](#)

### EC2 clusters spanning multiple regions and availability zones

When creating an EC2 cluster that spans multiple regions and availability zones, use OpsCenter to set up your cluster. You can use any of the [supported platforms](#). It is best practice to use the same platform on all nodes. If your cluster was instantiated using the DataStax AMI, use Ubuntu for the additional nodes. Configure the cluster as a [multiple data center cluster](#) using the [Ec2MultiRegionSnitch](#). The following topics describe OpsCenter provisioning:

- [Provisioning a new cluster](#)
- [Adding an existing cluster](#)
- [Adding nodes to a cluster](#)

### Production Cassandra clusters on EC2

For production Cassandra clusters on EC2, use these guidelines for choosing the instance types:

- Development and light production: **m3.large**
- Moderate production: **m3.xlarge**
- SSD production with light data: **c3.2xlarge**
- Largest heavy production: **m3.2xlarge** (PV) or **i2.2xlarge** (HVM)

**Note:** The main difference between **m1** and **m3** instance types for use with Cassandra is that **m3** instance types have faster, smaller SSD drives and **m1** instance types have slower, larger rotational drives. Use **m1** instance types when you have higher tolerance for latency SLAs and you require smaller cluster sizes, or both. For more aggressive workloads use **m3** instance types with appropriately sized clusters.

### EBS volumes are not recommended

EBS volumes are not recommended for Cassandra data storage volumes for the following reasons:

- EBS volumes contend directly for network throughput with standard packets. This contention means that EBS throughput is likely to fail if you saturate a network link.
- EBS volumes have unreliable performance. I/O performance can be exceptionally slow, causing the system to back load reads and writes until the entire cluster becomes unresponsive.

## Planning a cluster deployment

- Adding capacity by increasing the number of EBS volumes per host does not scale. You can easily surpass the ability of the system to keep effective buffer caches and concurrently serve requests for all of the data it is responsible for managing.

**Note:** Use only ephemeral **instance-store** devices for Cassandra data storage.

For more information and graphs related to ephemeral versus EBS performance, see the blog article [Systematic Look at EC2 I/O](#).

### Disk Performance Optimization

To ensure high disk performance to mounted drives, it is recommended that you pre-warm your drives by writing once to every drive location before production use. Depending on EC2 conditions, you can get moderate to enormous increases in throughput. See [Optimizing Disk Performance](#) in the *Amazon Elastic Compute Cloud Documentation*.

### Storage recommendations for Cassandra 1.2 and later

Cassandra 1.2 and later supports JBOD (just a bunch of disks). JBOD excels at tolerating partial failures in a disk array. Configure using the `disk_failure_policy` in the `cassandra.yaml` file. Additional information is available in the [Handling Disk Failures In Cassandra 1.2](#) blog and [Recovering using JBOD](#).

**Note:** Cassandra JBOD support allows you to use standard disks. However, RAID0 may provide better throughput because it splits every block to be on another device. This means that writes are written in parallel fashion instead of written serially on disk.

The location of the `cassandra.yaml` file depends on the type of installation:

Package installations	<code>/etc/cassandra/cassandra.yaml</code>
Tarball installations	<code>install_location/resources/cassandra/conf/cassandra.yaml</code>

### Storage recommendations for Cassandra 1.1 and earlier

RAID 0 the ephemeral disks. Then put both the data directory and the commit log on that volume. This has proved to be better in practice than putting the commit log on the root volume, which is also a shared resource. For more data redundancy, consider deploying your Cassandra cluster across multiple availability zones or using EBS volumes to store your Cassandra backup files.

## Calculating usable disk capacity

Determining how much data your Cassandra nodes can hold.

### About this task

To calculate how much data your Cassandra nodes can hold, calculate the usable disk capacity per node and then multiply that by the number of nodes in your cluster. Remember that in a production cluster, you will typically have your commit log and data directories on different disks.

### Procedure

1. Start with the raw capacity of the physical disks:

```
raw_capacity = disk_size * number_of_data_disks
```



2. Calculate the formatted disk space as follows:

```
formatted_disk_space = (raw_capacity * 0.9)
```

During normal operations, Cassandra routinely requires disk capacity for compaction and repair operations. For optimal performance and cluster health, DataStax recommends not filling your disks to capacity, but running at 50% to 80% capacity depending on the **compaction strategy** and size of the compactions.

3. Calculate the usable disk space accounting for file system formatting overhead (roughly 10 percent):

```
usable_disk_space = formatted_disk_space * (0.5 to 0.8)
```

## Calculating user data size

Accounting for storage overhead in determining user data size.

### About this task

The size of your raw data may be larger or smaller once it is loaded into Cassandra due to storage overhead. How much depends on how well it compresses and the characteristics of your data and tables. The following calculations account for data persisted to disk, not for data stored in memory.

### Procedure

- Determine column overhead:

```
regular_total_column_size = column_name_size + column_value_size + 15
```

```
counter - expiring_total_column_size = column_name_size +
column_value_size + 23
```

Every column in Cassandra incurs 15 bytes of overhead. Since each row in a table can have different column names as well as differing numbers of columns, metadata is stored for each column. For counter columns and expiring columns, you should add an additional 8 bytes (23 bytes total).

- Account for row overhead.  
Every row in Cassandra incurs 23 bytes of overhead.
- Estimate primary key index size:

```
primary_key_index = number_of_rows * ( 32 + average_key_size )
```

Every table also maintains a partition index. This estimation is in bytes.

- Determine replication overhead:

```
replication_overhead = total_data_size * ( replication_factor - 1 )
```

The replication factor plays a role in how much disk capacity is used. For a replication factor of 1, there is no overhead for replicas (as only one copy of data is stored in the cluster). If replication factor is greater than 1, then your total data storage requirement will include replication overhead.

### Anti-patterns in Cassandra

Implementation or design patterns that are ineffective and/or counterproductive in Cassandra production installations. Correct patterns are suggested in most cases.

Implementation or design patterns that are ineffective and/or counterproductive in Cassandra production installations. Correct patterns are suggested in most cases.

#### Storage area network

SAN storage is **not** recommended for on-premises deployments. DataStax does not support SAN-backed deployments.

**Note:** Storage in clouds works very differently. Customers should contact DataStax for questions.

Although used frequently in Enterprise IT environments, SAN storage has proven to be a difficult and expensive architecture to use with distributed databases for a variety of reasons, including:

- SAN ROI does not scale along with that of Cassandra, in terms of capital expenses and engineering resources.
- In distributed architectures, SAN generally introduces a bottleneck and single point of failure because Cassandra's IO frequently surpasses the array controller's ability to keep up.
- External storage, even when used with a high-speed network and SSD, adds latency for all operations.
- Heap pressure is increased because pending I/O operations take longer.
- When the SAN transport shares operations with internal and external Cassandra traffic, it can saturate the network and lead to network availability problems.

Taken together these factors can create problems that are difficult to resolve in production. In particular, new users deploying Cassandra with SAN must first develop adequate methods and allocate sufficient engineering resources to identify these issues before they become a problem in production. For example, methods are needed for all key scaling factors, such as operational rates and SAN fiber saturation.

**Impact of Shared Storage on Cassandra** details metrics on how severely performance can be affected.

#### Network attached storage

Storing SSTables on a network attached storage (NAS) device is not recommended. Using a NAS device often results in network related bottlenecks resulting from high levels of I/O wait time on both reads and writes. The causes of these bottlenecks include:

- Router latency.
- The Network Interface Card (NIC) in the node.
- The NIC in the NAS device.

If you are required to use NAS for your environment, please contact a technical resource from DataStax for assistance.

#### Shared network file systems

Shared network file systems (NFS) have the same limitations as NAS. The temptation with NFS implementations is to place all SSTables in a node into one NFS. Doing this deprecates one of Cassandra's strongest features: No Single Point of Failure (SPOF). When all SSTables from all nodes are stored onto a single NFS, the NFS becomes a SPOF. To best use Cassandra, avoid using NFS.

#### Excessive heap space size

DataStax recommends using the default heap space size for most use cases. Exceeding this size can impair the Java virtual machine's (JVM) ability to perform fluid garbage collections (GC). The following table shows a comparison of heap space performances reported by a Cassandra user:

Heap	CPU utilization	Queries per second	Latency
40 GB	50%	750	1 second
8 GB	5%	8500 (not maxed out)	10 ms

For information on heap sizing, see [Tuning Java resources](#).

### Cassandra's rack feature

This information applies only to single-token architecture, not to [virtual nodes](#).

Defining one rack for the entire cluster is the simplest and most common implementation. Multiple racks should be avoided for the following reasons:

- Most users tend to ignore or forget rack requirements that racks should be organized in an alternating order. This order allows the data to get distributed safely and appropriately.
- Many users are not using the rack information effectively. For example, setting up with as many racks as nodes (or similar non-beneficial scenarios).
- Expanding a cluster when using racks can be tedious. The procedure typically involves several node moves and must ensure that racks are distributing data correctly and evenly. When clusters need immediate expansion, racks should be the last concern.

To use racks correctly:

- Use the same number of nodes in each rack.
- Use one rack and place the nodes in different racks in an alternating pattern. This allows you to still get the benefits of Cassandra's rack feature, and allows for quick and fully functional cluster expansions. Once the cluster is stable, you can swap nodes and make the appropriate moves to ensure that nodes are placed in the ring in an alternating fashion with respect to the racks.

Also see [About Replication in Cassandra](#) in the Cassandra 1.1 documentation.

### SELECT ... IN or index lookups

SELECT ... IN and index lookups (formerly secondary indexes) should be avoided except for specific scenarios. See *When not to use IN* in [SELECT](#) and *When not to use an index* in [Indexing in CQL for Cassandra 2.0](#).

### Using the Byte Ordered Partitioner

The Byte Ordered Partitioner (BOP) is not recommended.

Use [virtual nodes](#) (vnodes) and use either the [Murmur3Partitioner](#) (default) or the [RandomPartitioner](#). Vnodes allow each node to own a large number of small ranges distributed throughout the cluster. Using vnodes saves you the effort of generating tokens and assigning tokens to your nodes. If not using vnodes, these partitioners are recommended because all writes occur on the hash of the key and are therefore spread out throughout the ring amongst tokens range. These partitioners ensure that your cluster evenly distributes data by placing the key at the correct token using the key's hash value.

### Reading before writing

Reads take time for every request, as they typically have multiple disk hits for uncached reads. In work flows requiring reads before writes, this small amount of latency can affect overall throughput. All write I/O in Cassandra is sequential so there is very little performance difference regardless of data size or key distribution.

## Planning a cluster deployment

### Load balancers

Cassandra was designed to avoid the need for load balancers. Putting load balancers between Cassandra and Cassandra clients is harmful to performance, cost, availability, debugging, testing, and scaling. All high-level clients, such as the [Java](#) and [Python](#) drivers for Cassandra, implement load balancing directly.

### Insufficient testing

Be sure to test at scale and production loads. This the best way to ensure your system will function properly when your application goes live. The information you gather from testing is the best indicator of what throughput per node is needed for future expansion calculations.

To properly test, set up a small cluster with production loads. There will be a maximum throughput associated with each node count before the cluster can no longer increase performance. Take the maximum throughput at this cluster size and apply it linearly to a cluster size of a different size. Next extrapolate (graph) your results to predict the correct cluster sizes for required throughputs for your production cluster. This allows you to predict the correct cluster sizes for required throughputs in the future. The [Netflix case study](#) shows an excellent example for testing.

### Too many keyspaces or tables

Each Cassandra keyspace has a certain amount of overhead space that uses JVM memory. Each table uses approximately 1MB of memory. For example, 3,500 tables would use about 3.5TB of JVM memory. Using too many tables, or by extension, too many keyspaces will bloat the memory requirements. A good rule of thumb is to keep the number of tables within a cluster to 1,000 at most, and aim for 500 or less.

### Lack of familiarity with Linux

Linux has a great collection of tools. Become familiar with the Linux built-in tools. It will help you greatly and ease operation and management costs in normal, routine functions. The essential list of tools and techniques to learn are:

- Parallel SSH and Cluster SSH: The pssh and cssh tools allow SSH access to multiple nodes. This is useful for inspections and cluster wide changes.
- Passwordless SSH: SSH authentication is carried out by using public and private keys. This allows SSH connections to easily hop from node to node without password access. In cases where more security is required, you can implement a bastion host and/or VPN.
- Useful common command-line tools include:
  - dstat: Shows all system resources instantly. For example, you can compare disk usage in combination with interrupts from your IDE controller, or compare the network bandwidth numbers directly with the disk throughput (in the same interval).
  - top: Provides an ongoing look at CPU processor activity in real time.
  - System performance tools: Tools such as iostat, mpstat, iftop, sar, lsof, netstat, htop, vmstat, and similar can collect and report a variety of metrics about the operation of the system.
  - vmstat: Reports information about processes, memory, paging, block I/O, traps, and CPU activity.
  - iftop: Shows a list of network connections. Connections are ordered by bandwidth usage, with the pair of hosts responsible for the most traffic at the top of list. This tool makes it easier to identify the hosts causing network congestion.

### Running without the recommended settings

Be sure to use the [recommended settings](#) in the Cassandra documentation.

Also be sure to consult the [Planning a Cassandra cluster deployment](#) documentation, which discusses hardware and other recommendations before making your final hardware purchases.

### More anti-patterns

For more about anti-patterns, visit [Matt Dennis` slideshare](#).

# Installing DataStax Community

Various installation methods.

## Installing DataStax Community on RHEL-based systems

Install using Yum repositories on RHEL, CentOS, and Oracle Linux.

### About this task

Use these steps to install Cassandra using Yum repositories on RHEL, CentOS, and Oracle Linux.

**Note:** To install on SUSE, use the [Cassandra binary tarball distribution](#).

For a complete list of supported platforms, see [DataStax Community – Supported Platforms](#).

### Before you begin

- Yum Package Management application installed.
- Root or sudo access to the install machine.
- Latest version of Oracle Java SE Runtime Environment (JRE) 8 (recommended) or [OpenJDK 7](#).
- Python 2.6+ (needed if installing OpsCenter).

### About this task

The packaged releases create a `cassandra` user. When starting Cassandra as a service, the service runs as this user. The following utilities are included in a separate package: `sstable2json`, `sstablelevelreset`, `sstablemetadata`, `json2sstable`, `sstable repairedset`, `sstablesplit`, and `token-generator`.

### Procedure

In a terminal window:

1. Check which version of Java is installed by running the following command:

```
$ java -version
```

It is recommended to use the latest version of Oracle Java 8 on all nodes. (Oracle Java 7 is also supported.)

See [Installing the JRE on RHEL-based systems](#).

2. Add the DataStax Community repository to the `/etc/yum.repos.d/datastax.repo`:

```
[datastax]
name = DataStax Repo for Apache Cassandra
baseurl = http://rpm.datastax.com/community
enabled = 1
gpgcheck = 0
```

3. Install the packages:

```
$ sudo yum install dsc21
$ sudo yum install cassandra21-tools ## Installs optional utilities.
```

The DataStax Community distribution of Cassandra is ready for configuration.

## Installing DataStax Community

### What to do next

- Initializing a multiple node cluster (single data center)
- Initializing a multiple node cluster (multiple data centers)
- Recommended production settings
- Installing OpsCenter
- Key components for configuring Cassandra
- Starting Cassandra as a service
- Package installation directories

## Installing DataStax Community on Debian-based systems

Install using APT repositories on Debian and Ubuntu.

### About this task

Use these steps to install Cassandra using APT repositories on Debian and Ubuntu Linux.

For a complete list of supported platforms, see [DataStax Community – Supported Platforms](#).

### Before you begin

- Advanced Package Tool is installed.
- Root or sudo access to the install machine.
- Python 2.6+ (needed if installing OpsCenter).
- Latest version of Oracle Java SE Runtime Environment (JRE) 8 (recommended) or [OpenJDK 7](#).

### About this task

The packaged releases create a `cassandra` user. When starting Cassandra as a service, the service runs as this user. The following utilities are included in a separate package: `sstable2json`, `sstablelevelreset`, `sstablemetadata`, `json2sstable`, `sstablerepairedset`, `sstablesplit`, and `token-generator`.

### Procedure

In a terminal window:

1. Check which version of Java is installed by running the following command:

```
$ java -version
```

It is recommended to use the latest version of Oracle Java 8 on all nodes. (Oracle Java 7 is also supported.)

See [Installing the JRE on RHEL-based systems](#).

2. Add the DataStax Community repository to the `/etc/apt/sources.list.d/cassandra.sources.list`

```
$ echo "deb http://debian.datastax.com/community stable main" | sudo tee -a /etc/apt/sources.list.d/cassandra.sources.list
```

3. Debian systems only:

- a) In `/etc/apt/sources.list`, find the line that describes your source repository for Debian and add `contrib non-free` to the end of the line. For example:

```
deb http://some.debian.mirror/debian/ $distro main contrib non-free
```

This allows installation of the Oracle JVM instead of the OpenJDK JVM.

b) Save and close the file when you are done adding/editing your sources.

4. Add the DataStax repository key to your aptitude trusted keys.

```
$ curl -L http://debian.datastax.com/debian/repo_key | sudo apt-key add -
```

5. Install the latest package:

```
$ sudo apt-get update
$ sudo apt-get install dsc21
$ sudo apt-get install cassandra-tools ## Optional utilities
```

This installs the DataStax Community distribution of Cassandra .

6. Because the Debian packages start the Cassandra service automatically, you must stop the server and clear the data:

Doing this removes the default `cluster_name` (Test Cluster) from the system table. All nodes must use the same cluster name.

```
$ sudo service cassandra stop
$ sudo rm -rf /var/lib/cassandra/data/system/*
```

The DataStax Community distribution of Cassandra is ready for configuration.

### What to do next

- [Initializing a multiple node cluster \(single data center\)](#)
- [Initializing a multiple node cluster \(multiple data centers\)](#)
- [Recommended production settings](#)
- [Installing OpsCenter](#)
- [Key components for configuring Cassandra](#)
- [Starting Cassandra as a service](#)
- [Package installation directories](#)

## Installing DataStax Community on any Linux-based platform

Install on all Linux-based platforms using a binary tarball.

### About this task

Use these steps to install Cassandra on all Linux-based platforms using a binary tarball.

### About this task

Use this install for Mac OS X and platforms without package support, or if you do not have or want a root installation.

For a complete list of supported platforms, see [DataStax Community – Supported Platforms](#).

### Before you begin

- Latest version of Oracle Java SE Runtime Environment (JRE) 8 (recommended) or [OpenJDK 7](#).
- Python 2.6+ (needed if installing OpsCenter).
- If you are using an older RHEL-based Linux distribution, such as CentOS-5, you may see the following error: `GLIBCXX_3.4.9 not found`. You must replace the Snappy compression/decompression library (`snappy-java-1.0.5.jar`) with the [snappy-java-1.0.4.1.jar](#).

## Installing DataStax Community

### About this task

The binary tarball runs as a stand-alone process.

### Procedure

In a terminal window:

1. Check which version of Java is installed by running the following command:

```
$ java -version
```

It is recommended to use the latest version of Oracle Java 8 on all nodes. (Oracle Java 7 is also supported.)

See [Installing the JRE on RHEL-based systems](#).

2. Download the DataStax Community:

```
$ curl -L http://downloads.datastax.com/community/dsc.tar.gz | tar xz
```

You can also download from [Planet Cassandra](#).

3. Go to the install directory:

```
$ cd dsc-cassandra-2.1.x
```

The DataStax Community distribution of Cassandra is ready for configuration.

4. Go to the install directory:

```
$ cd install_location/apache-cassandra-2.1.x
```

Cassandra is ready for configuration.

### What to do next

- [Initializing a multiple node cluster \(single data center\)](#)
- [Initializing a multiple node cluster \(multiple data centers\)](#)
- [Recommended production settings](#)
- [Installing OpsCenter](#)
- [Key components for configuring Cassandra](#)
- [Tarball installation directories](#)
- [Starting Cassandra as a stand-alone process](#)

## Installing DataStax Community on Windows systems

About installing on Windows systems.

### About this task

To install or uninstall DataStax Community on Windows systems, see [Cassandra and DataStax Enterprise Essentials](#).



## Installing prior releases of DataStax Community

Steps for installing the same version as other nodes in your cluster.

### About this task

How to install the same version as other nodes in your cluster.

Follow the install instructions in the [relevant documentation](#) and specify the specific version in the install command.

### Installing the packages on RHEL-based platforms

Examples:

```
$ sudo yum install dsc21-2.1.2.1 cassandra21-2.1.2-1
$ sudo yum install dsc21-2.1.2.1 cassandra21-2.1.2-1 cassandra21-tools-2.1.2-1
## Optional
```

### Installing the packages on Debian-based platforms

Examples:

```
$ sudo apt-get install dsc21=2.1.2-1 cassandra=2.1.2
$ sudo apt-get install dsc21=2.1.2-1 cassandra=2.1.2 cassandra-tools=2.1.2 ##
Optional
```

### Installing from the binary tarball

1. Download the tarball using the URL for the prior version.

Cassandra 2.1.0 example:

```
http://downloads.datastax.com/community/dsc-cassandra-2.1.0-bin.tar.gz
```

Cassandra 2.1.3 example:

```
http://downloads.datastax.com/community/dsc-cassandra-2.1.3-bin.tar.gz
```

2. Unpack the distribution. For example:

```
$ tar -xzvf dsc-cassandra-2.1.3-bin.tar.gz
```

The files are extracted into the dsc-cassandra-2.1.3 directory.

## Uninstalling DataStax Community

Steps for uninstalling Cassandra by install type.

### About this task

Select the uninstall method for your type of installation.

### Uninstalling Debian- and RHEL-based packages

Use this method when you have installed DataStax Community using [APT](#) or [Yum](#).

1. Stop the Cassandra and DataStax Agent services:

## Installing DataStax Community

```
$ sudo service cassandra stop
```

2. Make sure all services are stopped:

```
$ ps auwx | grep cassandra
$ ps auwx | grep datastax-agent ## If the DataStax Agent was installed.
```

3. If services are still running, use the PID to kill the service:

```
$ sudo kill cassandra_pid
$ sudo kill datastax_agent_pid ## If the DataStax Agent was installed.
```

4. Remove the library and log directories:

```
$ sudo rm -r /var/lib/cassandra
$ sudo rm -r /var/log/cassandra
```

5. Remove the installation directories:

### RHEL-based packages:

```
$ sudo yum remove "cassandra-*" "datastax-*" ## datastax-x required if the
DataStax Agent was installed.
```

### Debian-based packages:

```
$ sudo apt-get purge "cassandra-*" "datastax-*" ## datastax-x required if
the DataStax Agent was installed..
```

## Uninstalling the binary tarball

Use this method when you have installed DataStax Community using the [binary tarball](#).

1. Stop the node:

```
$ ps auwx | grep cassandra
$ sudo kill <pid>
```

2. Stop the DataStax Agent if installed:

```
$ sudo kill datastax_agent_pid
```

3. Remove the installation directory.

## Installing on cloud providers

Installation methods for the supported cloud providers.

### Installing a Cassandra cluster on Amazon EC2

A step-by-step guide for installing the DataStax Community AMI (Amazon Machine Image).

#### About this task

The DataStax AMI allows you to set up a simple DataStax Community cluster using the [Amazon Web Services EC2 Management Console](#). Installing via the AMI allows you to quickly deploy a Cassandra cluster within a single availability zone.

The AMI does the following:

- Installs the latest version of Cassandra with an Ubuntu 12.04 LTS (Precise Pangolin), image (Ubuntu Cloud 20140227 release), Kernel 3.8+.
- Installs Oracle Java 7.
- Install metrics tools such as dstat, ethtool, make, gcc, and s3cmd.

- Uses RAID0 ephemeral disks for data storage and commit logs.
- Choice of PV (Para-virtualization) or HVM (Hardware-assisted Virtual Machine) instance types. See [Amazon documentation](#).
- Launches EBS-backed instances for faster start-up, **not** database storage.
- Uses the private interface for intra-cluster communication.
- Sets the seed nodes cluster-wide.
- Installs OpsCenter (by default).

**Note:** When creating an EC2 cluster that spans multiple regions and availability zones, use OpsCenter to set up your cluster. See [EC2 clusters spanning multiple regions and availability zones](#).

Because Amazon changes the EC2 console intermittently, these instructions have been generalized. For details on each step, see the [User guide](#) in the *Amazon Elastic Compute Cloud Documentation*.

To install a Cassandra cluster from the DataStax AML, complete the following tasks:

### Creating an EC2 security group

An EC2 Security Group acts as a firewall for designation which protocols and ports are open in your cluster.

#### About this task

An [EC2 Security Group](#) acts as a firewall that allows you to choose which protocols and ports are open in your cluster. You must specify a security group in the same region as your instances.

You can specify the protocols and ports either by a range of IP addresses or by security group. To protect your cluster, you should define a security group. Be aware that specifying a Source IP of 0.0.0.0/0 allows every IP address access by the specified protocol and port range.

#### Procedure

If you need more help, click an informational icon or a link to the *Amazon EC2 User Guide*.

1. Sign in to the [AWS console](#).
2. From the Amazon EC2 console navigation bar, select the same region as where you will launch the DataStax Community AML.

[Step 1](#) in [Launch instances](#) provides a list of the available regions.

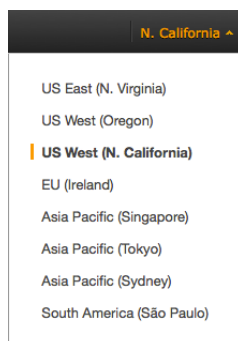

3. Open the **Security Groups** page.
4. Create a security group with a name and description of your choice, then save it. It is recommended that you include the region name in the description.

**Note:** Creating and saving the securing group allows you to create rules based on the group. After the security group is saved it is available in the **Source** field drop-list.

5. Create rules for the security group using the following table:

**Table 1: Ports**

Port number	Type	Protocol	Source	Description
<i>Public ports</i>				
22	SSH	TCP	0.0.0.0/0	SSH port
8888	Custom TCP Rule	TCP	0.0.0.0/0	OpsCenter website. The opscenterd daemon listens on this port for HTTP requests coming directly from the browser.
<i>Cassandra inter-node ports</i>				
1024 - 65355	Custom TCP Rule	TCP	Your security group	<i>Cassandra 1.2 or earlier only.</i> Because JMX connects on port 7199, handshakes, and then uses any port within the 1024+ range, use SSH to execute commands remotely to connect to JMX locally or use the DataStax OpsCenter.
7000	Custom TCP Rule	TCP	Your security group	Cassandra inter-node cluster communication.
7001	Custom TCP Rule	TCP	Your security group	Cassandra SSL inter-node cluster communication.
7199	Custom TCP Rule	TCP	Your security group	Cassandra JMX monitoring port.
<i>Cassandra client ports</i>				
9042	Custom TCP Rule	TCP	0.0.0.0/0	Cassandra client port.
9160	Custom TCP Rule	TCP	0.0.0.0/0	Cassandra client port (Thrift).
<i>OpsCenter inter-node ports</i>				
61620	Custom TCP Rule	TCP	Your security group	OpsCenter monitoring port. The opscenterd daemon listens on this port for TCP traffic coming from the agent.
61621	Custom TCP Rule	TCP	Your security group	OpsCenter agent port. The agents listen on this port for SSL traffic initiated by OpsCenter.

The completed port rules should look similar to this:

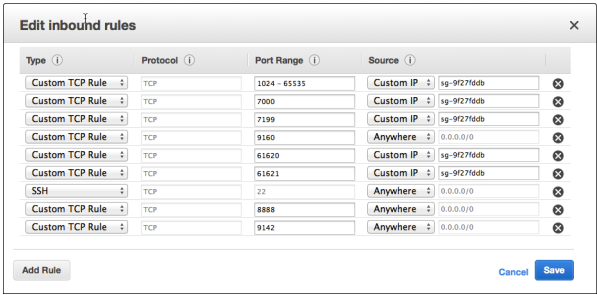

**Warning:** The security configuration shown in this example opens up all externally accessible ports to incoming traffic from any IP address (0.0.0.0/0). The risk of data loss is high. If you desire a more secure configuration, see the Amazon EC2 help on security groups.

**Creating a key pair**

Amazon EC2 uses public-key cryptography to encrypt and decrypt login information.

**About this task**

Amazon EC2 uses public-key cryptography to encrypt and decrypt login information. Public-key cryptography uses a public key to encrypt data and the recipient uses the private key to decrypt the data. The public and private keys are known as a *key pair*.

**Procedure**

You must create a key pair for each region you use.

1. From the Amazon EC2 console navigation bar, select the same region as where you will launch the DataStax Community AMI.

Step 1 in **Launch instances** provides a list of the available regions.

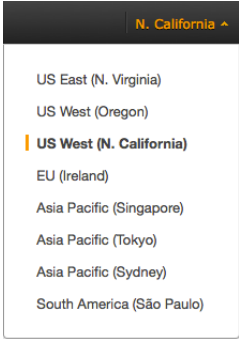

2. Create the key pair and save it to your home directory.
3. Set the permissions of your private key file so that only you can read it.

```
$ chmod 400 my-key-pair.pem
```

**Launching the DataStax Community AMI**

Launching your Cassandra Amazon Machine Images.

**About this task**

After creating the security group, you can launch your AMI instances.

**Procedure**

If you need more help, click an informational icon or a link to the *Amazon EC2 User Guide*.

1. Launch the AMI using the links in the following table:

Amazon EC2 offers a number of [geographic regions](#) for launching the AMI. Factors for choosing a region include: reduce latency, cost, or regulatory requirements.

Region	AMI
<i>HVM instances</i> (Hardware-assisted Virtual Machine - see <a href="#">Amazon documentation</a> .)	
us-east-1	<a href="#">ami-ada2b6c4</a>
us-west-1	<a href="#">ami-3cf7c979</a>
us-west-2	<a href="#">ami-1cff962c</a>
eu-west-1	<a href="#">ami-7f33cd08</a>
ap-southeast-1	<a href="#">ami-b47828e6</a>
ap-southeast-2	<a href="#">ami-55d54d6f</a>
ap-northeast-1	<a href="#">ami-714a3770</a>
sa-east-1	<a href="#">ami-1dda7800</a>
<i>PV instances</i> (Paravirtualization - see <a href="#">Amazon documentation</a> .)	
us-east-1	<a href="#">ami-f9a2b690</a>
us-west-1	<a href="#">ami-32f7c977</a>
us-west-2	<a href="#">ami-16ff9626</a>
eu-west-1	<a href="#">ami-8932ccfe</a>
ap-southeast-1	<a href="#">ami-8c7828de</a>
ap-southeast-2	<a href="#">ami-57d54d6d</a>
ap-northeast-1	<a href="#">ami-6b4a376a</a>
sa-east-1	<a href="#">ami-15da7808</a>

2. In **Step 2: Choose an Instance Type**, choose the appropriate type.

The recommended instances are:

- Development and light production: **m3.large**
- Moderate production: **m3.xlarge**
- SSD production with light data: **c3.2xlarge**
- Largest heavy production: **m3.2xlarge** (PV) or **i2.2xlarge** (HVM)
- Micro, small, and medium types are not supported.

**Note:** The main difference between **m1** and **m3** instance types for use with Cassandra is that **m3** instance types have faster, smaller SSD drives and **m1** instance types have slower, larger rotational drives. Use **m1** instance types when you have higher tolerance for latency SLAs and you require smaller cluster sizes, or both. For more aggressive workloads use **m3** instance types with appropriately sized clusters.

When the instance is selected, its specifications are displayed:

Currently selected: m3.large (6.5 ECUs, 2 vCPUs, 2.5 GHz, Intel Xeon E5-2670v2, 7.5 GiB memory, 1 x 32 GiB Storage Capacity)

Because Amazon updates instance types periodically, see the following docs to help you determine your hardware and storage requirements:

- [Planning a cluster deployment](#)
- [User guide](#) in the *Amazon Elastic Compute Cloud Documentation*
- [What is the story with AWS storage](#)
- [Get in the Ring with Cassandra and EC2](#)

3. Click **Next: Configure Instance Details** and configure the instances to suit your requirements:

- **Number of instances**
- **Network** - Select **Launch into EC2-Classical**.
- **Advanced Details** - Open and add the following options (as text) to the **User Data** section.

Option	Description
<code>--clustername name</code>	Required. The name of the cluster.
<code>--totalnodes #_nodes</code>	Required. The total number of nodes in the cluster.
<code>--version community</code>	Required. The version of the cluster. Use <code>community</code> to install the latest version of DataStax Community.
<code>--opscenter [no]</code>	Optional. By default, DataStax OpsCenter is installed on the first instance. Specify <code>no</code> to disable.
<code>--reflector url</code>	Optional. Allows you to use your own reflector. Default: <code>http://reflector2.datastax.com/reflector2.php</code>

For example: `--clustername myDSCcluster --totalnodes 6 --version community`

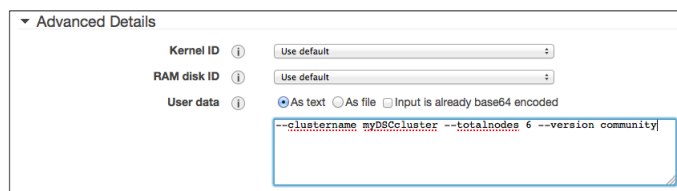

4. Click **Next: Add Storage**, and add volumes as needed.

The number of instance store devices available to the machine depends on the instance type. EBS volumes are **not** recommended for database storage.

5. Click **Next: Tag Instance** and give a name to your DSE instance, such as `workload-dsc`.

Tags enable you to categorize your AWS resources in different ways, such as purpose, owner, or environment.

6. Click **Next: Configure Security Group** and configure as follows:

- Choose **Select an existing security group**.
- Select the Security Group you created earlier.
- Click **Review and Launch**.

7. On the **Step 7: Review Instance Launch** page, make any needed changes.

8. Click **Launch** and then in the **Select an existing key pair or create a new key pair** dialog, do one of the following:

- Select an existing key pair from the **Select a key pair** drop list.

## Installing DataStax Community

- If you need to create a new key pair, click **Choose an existing key pair** drop list and select **Create a new key pair**. Then create the new key pair as described in [Create key pair](#).

### 9. Click **Launch Instances**.

The AMI image configures your cluster and starts Cassandra services. The **Launch Status** page is displayed.

### 10. Click **View Instances**.

## Connecting to your DataStax Community EC2 instance

Connect to your Cassandra EC2 instances from a terminal or SSH client.

### About this task

Once the cluster is launched, you can connect to it from a terminal or SSH client, such as PuTTY. Connect as user `ubuntu` rather than as `root`.

### Procedure

#### 1. If necessary, from the **EC2 Dashboard**, click **Running Instances**.

You can connect to any node in the cluster. However, one node (Node0) runs OpsCenter and is the **Cassandra seed** node.

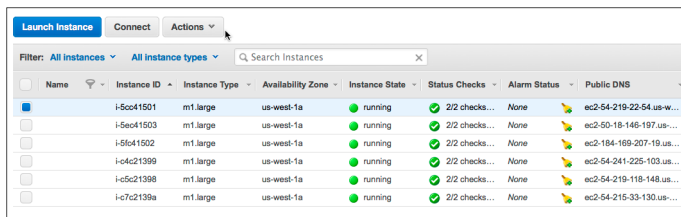

Name	Instance ID	Instance Type	Availability Zone	Instance State	Status Checks	Alarm Status	Public DNS
	i-5c041501	m1.large	us-west-1a	running	2/2 checks...	None	ec2-54-219-22-54-us-w...
	i-5e041503	m1.large	us-west-1a	running	2/2 checks...	None	ec2-50-18-146-197-us...
	i-5f041502	m1.large	us-west-1a	running	2/2 checks...	None	ec2-184-169-207-19.us...
	i-04c21399	m1.large	us-west-1a	running	2/2 checks...	None	ec2-54-241-325-103.us...
	i-c5c21398	m1.large	us-west-1a	running	2/2 checks...	None	ec2-54-219-118-148.us...
	i-c7c2139a	m1.large	us-west-1a	running	2/2 checks...	None	ec2-54-215-33-130.us...

#### 2. To find which instance is Node0:

- Select an instance.
- Select the **Description** tab.
- Scroll down the description information until you see **AMI launch index**.

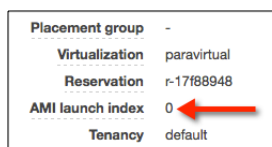

- Repeat until you find Node0.

#### 3. To get the public DNS name of a node, select the node you want to connect to, and then click **Connect**.

#### 4. In **Connect To Your Instance**, select **A standalone SSH client**.

#### 5. Copy the Example command line and change the user from `root` to `ubuntu`, then paste it into your SSH client.



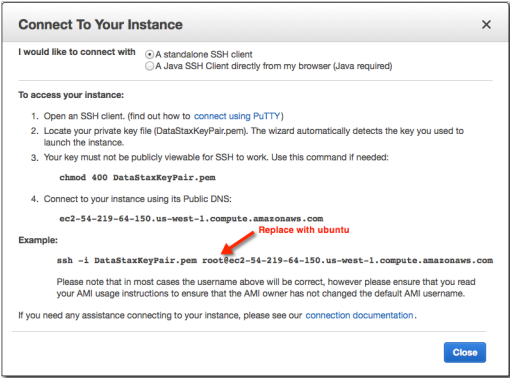

The AMI image configures your cluster and starts the Cassandra services.

- 6. After you have logged into a node and the AMI has completed installing and setting up the nodes, the status is displayed:

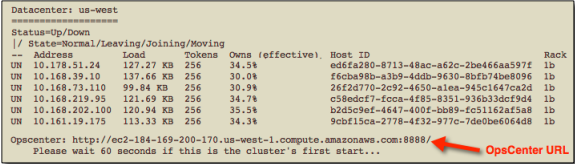

The URL for the OpsCenter is displayed when you connect to the node containing it; otherwise it is not displayed.

- 7. If you installed OpsCenter, allow 60 to 90 seconds after the cluster has finished initializing for OpsCenter to start. You can launch OpsCenter using the URL: `http://public_dns_of_first_instance:8888/`

The Dashboard should show that the agents are connected.

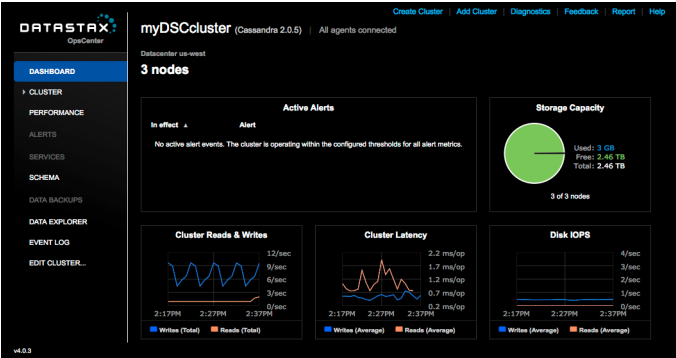

- 8. If the agents have not automatically connected:
  - a) Click the **Fix** link located near the top left of the **Dashboard**.



- b) When prompted for credentials for the agent nodes, use the username `ubuntu` and copy and paste the entire contents from your private key (`.pem`).

## Installing DataStax Community

The Dashboard shows the agents are connected.

### Clearing the data for an AMI restart

Clearing the data for an Amazon Machine Image restart.

#### About this task

Use these steps to clear the data for an Amazon Machine Image (AMI) restart. The logs for AMIs are stored in the same location as the data. To preserve the log files, you need to delete everything except the log directory.

#### Procedure

To clear the data from the **default** directories:

After **stopping** the service, run the following command:

```
$ sudo rm -rf /var/lib/cassandra/commitlog
$ sudo rm -rf /var/lib/cassandra/data
$ sudo rm -rf /var/lib/cassandra/saved_caches
```

### Expanding a Cassandra AMI cluster

Adding nodes to a Cassandra AMI cluster.

#### About this task

The best way to expand your EC2 implementations is to use OpsCenter:

- [Provisioning a new cluster](#)
- [Adding an existing cluster](#)
- [Adding nodes to a cluster](#)

## Installing and deploying a Cassandra cluster using GoGrid

Steps for installing and deploying a developer (3-node) or production (5-node) Cassandra cluster using GoGrid's 1-Button Deploy.

#### About this task

You can use GoGrid's 1-Button Deploy for installing and deploying a developer (3-node) or production (5-node) Cassandra cluster. Additional introductory documentation is available from GoGrid at:

- [GoGrid Cassandra Wiki](#)
- [Getting Started](#)

The 1-Button Deploy of Cassandra does the following:

- Installs the latest version of Cassandra on X-Large SSD Cloud Servers running Debian 7.2.
- Installs OpsCenter.
- Installs Oracle JDK 7.
- Installs Python Driver.
- Enables the Firewall Service - All services are blocked except SSH (22) and ping for public traffic.
- Deploys Cassandra using **virtual nodes** (vnodes).

#### Procedure

1. [Register](#) with GoGrid.
2. Fill out the registration form and complete the account verification.
3. Access the [management console](#) with the login credentials you received in your email.

Your cluster automatically starts deploying. A green status indicator shows that a server is up and running.

Hover over any item to view its details or right-click to display a context menu.

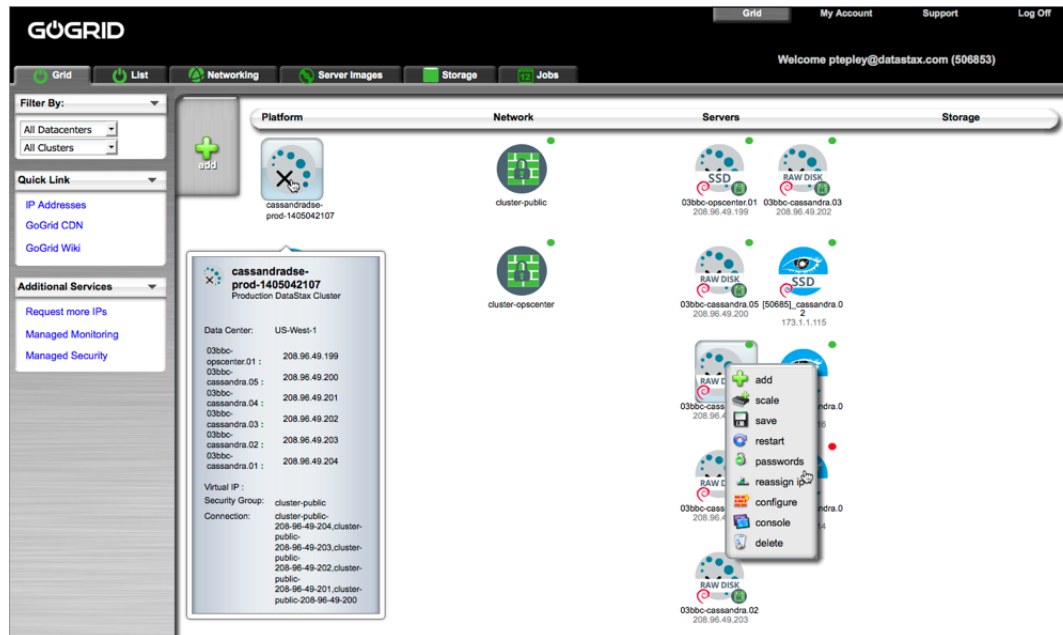

#### 4. Login to one of the servers and validate that the servers are configured and communicating:

**Note:** You can login to any member of the cluster either with SSH, a third-party client (like PuTTY), or through the GoGrid Console service.

- To find your server credentials, right-click the server and select **Passwords**.
- From your secure Data connection client, login to the server with the proper credentials. For example from SSH:

```
$ ssh root@ip_address
```

- Validate that the cluster is running:

```
$ nodestool status
```

Each node should be listed and its status and state should be UN (Up Normal):

```
Datacenter: datacenter1
=====
Status=Up/Down | / State=Normal/Leaving/Joining/Moving
-- Address          Load          Tokens Owns (effective)  Host ID
              Rack
UN 10.110.94.2      71.46 KB      256    65.9%
    3ed072d6-49cb-4713-bd55-ea4de25576a9  rack1
UN 10.110.94.5      40.91 KB      256    66.7%
    d5d982bc-6e30-40a0-8fe7-e46d6622c1d5  rack1
UN 10.110.94.4      73.33 KB      256    67.4%
    d9e5-43c8-85fa-5420db785052  rack1
```

### What to do next

The following provides information about using and configuring Cassandra, OpsCenter, GoGrid, and the Cassandra Query Language (CQL):

- [About Apache Cassandra](#)

## Installing DataStax Community

- [OpsCenter documentation](#)
- [GoGrid documentation](#)
- [CQL for Cassandra 2.x](#)

## Installing the Oracle JRE

Instructions for various platforms.

### Installing Oracle JRE on RHEL-based Systems

You must configure your operating system to use the Oracle JRE 7 or 8, or OpenJDK 7.

#### About this task

Configure your operating system to use the latest version of [Oracle Java SE Runtime Environment 8](#) or [OpenJDK 7](#).

**Note:** After installing the JRE, you may need to set `JAVA_HOME` to your profile:

For shell or bash: `export JAVA_HOME=path_to_java_home`

For csh (C shell): `setenv JAVA_HOME=path_to_java_home`

#### Procedure

1. Check which version of the JRE your system is using:

```
$ java -version
```

If Oracle Java is used, the results should look like:

```
java version "1.8.0_45"  
Java(TM) SE Runtime Environment (build 1.8.0_45-b14)  
Java HotSpot(TM) 64-Bit Server VM (build 25.45-b02, mixed mode)
```

2. If necessary, go to [Oracle Java SE Downloads](#), accept the license agreement, and download the installer for your distribution.

**Note:** If installing the Oracle JRE in a cloud environment, accept the license agreement, download the installer to your local client, and then use `scp` (secure copy) to transfer the file to your cloud machines.

3. From the directory where you downloaded the package, run the install:

```
$ sudo rpm -ivh jre-8uversion-linux-x64.rpm
```

The RPM installs the JRE into the `/usr/java/` directory.

4. Use the `alternatives` command to add a symbolic link to the Oracle JRE installation so that your system uses the Oracle JRE instead of the OpenJDK JRE:

```
$ sudo alternatives --install /usr/bin/java java /usr/java/  
jre1.8.0_version/bin/java 200000
```

If you have any problems, set the `PATH` and `JAVA_HOME` variables:

```
export PATH="$PATH:/usr/java/latest/bin"  
set JAVA_HOME=/usr/java/latest
```

5. Make sure your system is now using the correct JRE. For example:

```
$ java -version
```

```
java version "1.8.0_45"
Java(TM) SE Runtime Environment (build 1.8.0_45-b14)
Java HotSpot(TM) 64-Bit Server VM (build 25.45-b02, mixed mode)
```

6. If the OpenJDK JRE is still being used, use the `alternatives` command to switch it. For example:

```
$ sudo alternatives --config java
```

There are 2 programs which provide java.

Selection	Command
1	/usr/lib/jvm/jre-1.7.0-openjdk.x86_64/bin/java
*+ 2	/usr/java/jre1.8.0_45/bin/java

Enter to keep the current selection [+ ], or type selection number:

## Installing Oracle JRE on Debian or Ubuntu Systems

Steps for installing Oracle Java on Debian-based systems.

### About this task

Configure your operating system to use the latest version of [Oracle Java SE Runtime Environment 8](#) or [OpenJDK 7](#).

**Note:** After installing the JRE, you may need to set `JAVA_HOME` to your profile:

For shell or bash: `export JAVA_HOME=path_to_java_home`

For csh (C shell): `setenv JAVA_HOME=path_to_java_home`

### About this task

The Oracle Java Runtime Environment (JRE) has been removed from the official software repositories of Ubuntu and only provides a binary (`.bin`) version. You can get the JRE from the [Java SE Downloads](#).

### Procedure

1. Check which version of the JRE your system is using:

```
$ java -version
```

If Oracle Java is used, the results should look like:

```
java version "1.8.0_45"
Java(TM) SE Runtime Environment (build 1.8.0_45-b14)
Java HotSpot(TM) 64-Bit Server VM (build 25.45-b02, mixed mode)
```

2. If necessary, go to [Oracle Java SE Downloads](#), accept the license agreement, and download the installer for your distribution.

**Note:** If installing the Oracle JRE in a cloud environment, accept the license agreement, download the installer to your local client, and then use `scp` (secure copy) to transfer the file to your cloud machines.

## Installing DataStax Community

3. Make a directory for the JRE:

```
$ sudo mkdir -p /usr/lib/jvm
```

4. Unpack the tarball and install the JRE:

```
$ sudo tar zxvf jre-7u25-linux-x64.tar.gz -C /usr/lib/jvm
```

The JRE files are installed into a directory called `/usr/lib/jvm/jre-7u_version`.

5. Tell the system that there's a new Java version available:

```
$ sudo update-alternatives --install "/usr/bin/java" "java" "/usr/lib/jvm/jre1.8.0_version/bin/java" 1
```

If updating from a previous version that was removed manually, execute the above command twice, because you'll get an error message the first time.

6. Set the new JRE as the default:

```
$ sudo update-alternatives --set java /usr/lib/jvm/jre1.8.0_version/bin/java
```

7. Make sure your system is now using the correct JRE. For example:

```
$ java -version
```

```
java version "1.8.0_45"  
Java(TM) SE Runtime Environment (build 1.8.0_45-b14)  
Java HotSpot(TM) 64-Bit Server VM (build 25.45-b02, mixed mode)
```

## Recommended production settings

Recommendations for production environments.

Recommendations for production environments; adjust them accordingly for your implementation.

### Optimizing SSDs

For the majority of Linux distributions, SSDs are not configured optimally by default. The following steps ensures best practice settings for SSDs:

1. Ensure that the SysFS rotational flag is set to false (zero).

This overrides any detection by the operating system to ensure the drive is considered an SSD.

2. Repeat for any block devices created from SSD storage, such as mdarrays.

3. Set the IO scheduler to either deadline or noop:

- The noop scheduler is the right choice when the target block device is an array of SSDs behind a high-end IO controller that performs IO optimization.
- The deadline scheduler optimizes requests to minimize IO latency. If in doubt, use the deadline scheduler.

4. Set the read-ahead value for the block device to 8KB.

This setting tells the operating system not to read extra bytes, which can increase IO time and pollute the cache with bytes that weren't requested by the user.

For example, if the SSD is `/dev/sda`, in `/etc/rc.local`:

```
echo deadline > /sys/block/sda/queue/scheduler
```

```
#OR...
#echo noop > /sys/block/sda/queue/scheduler
#echo 0 > /sys/class/block/sda/queue/rotational
#echo 8 > /sys/class/block/sda/queue/read_ahead_kb
```

### Disable zone\_reclaim\_mode on NUMA systems

The Linux kernel can be inconsistent in enabling/disabling zone\_reclaim\_mode. This can result in odd performance problems.

To ensure that zone\_reclaim\_mode is disabled:

```
$ echo 0 > /proc/sys/vm/zone_reclaim_mode
```

For more information, see [Peculiar Linux kernel performance problem on NUMA systems](#).

### User resource limits

You can view the current limits using the `ulimit -a` command. Although limits can also be temporarily set using this command, DataStax recommends making the changes permanent:

Packaged installs: Ensure that the following settings are included in the `/etc/security/limits.d/cassandra.conf` file:

```
cassandra - memlock unlimited
cassandra - nofile 100000
cassandra - nproc 32768
cassandra - as unlimited
```

Tarball installs: Ensure that the following settings are included in the `/etc/security/limits.conf` file:

```
* - memlock unlimited
* - nofile 100000
* - nproc 32768
* - as unlimited
```

If you run Cassandra as root, some Linux distributions such as Ubuntu, require setting the limits for root explicitly instead of using `*`:

```
root - memlock unlimited
root - nofile 100000
root - nproc 32768
root - as unlimited
```

For CentOS, RHEL, OEL systems, also set the nproc limits in `/etc/security/limits.d/90-nproc.conf`:

```
* - nproc 32768
```

For all installations, add the following line to `/etc/sysctl.conf`:

```
vm.max_map_count = 131072
```

To make the changes take effect, reboot the server or run the following command:

```
$ sudo sysctl -p
```

To confirm the limits are applied to the Cassandra process, run the following command where `pid` is the process ID of the currently running Cassandra process:

```
$ cat /proc/<pid>/limits
```

## Installing DataStax Community

For more information, see [Insufficient user resource limits errors](#).

### Disable swap

You must disable swap entirely. Failure to do so can severely lower performance. Because Cassandra has multiple replicas and transparent failover, it is preferable for a replica to be killed immediately when memory is low rather than go into swap. This allows traffic to be immediately redirected to a functioning replica instead of continuing to hit the replica that has high latency due to swapping. If your system has a lot of DRAM, swapping still lowers performance significantly because the OS swaps out executable code so that more DRAM is available for caching disks.

If you insist on using swap, you can set `vm.swappiness=1`. This allows the kernel swap out the absolute least used parts.

```
$ sudo swapoff --all
```

To make this change permanent, remove all swap file entries from `/etc/fstab`.

For more information, see [Nodes seem to freeze after some period of time](#).

### Synchronize clocks

The clocks on all nodes should be synchronized. You can use NTP (Network Time Protocol) or other methods.

This is required because columns are only overwritten if the timestamp in the new version of the column is more recent than the existing column.

### Optimum blockdev --setra settings for RAID

Typically, a readahead of 128 is recommended, especially on Amazon EC2 RAID0 devices.

Check to ensure setra is not set to 65536:

```
$ sudo blockdev --report /dev/<device>
```

To set setra:

```
$ sudo blockdev --setra 128 /dev/<device>
```

### Java Virtual Machine

The latest 64-bit version of Java 8 is recommended or [OpenJDK 7](#).



# Initializing a cluster

Topics for deploying a cluster.

## Initializing a multiple node cluster (single data center)

A deployment scenario for a Cassandra cluster with a single data center.

### About this task

This topic contains information for deploying a Cassandra cluster with a single data center. If you're new to Cassandra, and haven't set up a cluster, see [Cassandra and DataStax Enterprise Essentials](#) or [10 Minute Cassandra Walkthrough](#).

### Before you begin

Each node must be correctly configured before starting the cluster. You must determine or perform the following before starting the cluster:

- A good understanding of how Cassandra works. Be sure to read at least [Understanding the architecture](#), [Data replication](#), and [Cassandra's rack feature](#).
- Install Cassandra on each node.
- Choose a name for the cluster.
- Get the IP address of each node.
- Determine which nodes will be seed nodes. **Do not make all nodes seed nodes.** Please read [Internode communications \(gossip\)](#).
- Determine the [snitch](#) and [replication strategy](#). The [GossipingPropertyFileSnitch](#) and [NetworkTopologyStrategy](#) are recommended for production environments.
- If using multiple data centers, determine a naming convention for each data center and rack, for example: DC1, DC2 or 100, 200 and RAC1, RAC2 or R101, R102. Choose the name carefully; renaming a data center is not possible.
- Other possible configuration settings are described in [cassandra.yaml configuration file](#) and property files such as `cassandra-rackdc.properties`.

### About this task

This example describes installing a 6 node cluster spanning 2 racks in a single data center. Each node is configured to use the [GossipingPropertyFileSnitch](#) and 256 virtual nodes (vnodes).

In Cassandra, the term data center is a grouping of nodes. Data center is synonymous with replication group, that is, a grouping of nodes configured together for replication purposes.

### Procedure

1. Suppose you install Cassandra on these nodes:

```
node0 110.82.155.0 (seed1)
node1 110.82.155.1
node2 110.82.155.2
node3 110.82.156.3 (seed2)
node4 110.82.156.4
node5 110.82.156.5
```

**Note:** It is a best practice to have more than one seed node per data center.

## Initializing a cluster

2. If you have a firewall running in your cluster, you must open certain ports for communication between the nodes. See [Configuring firewall port access](#).

3. If Cassandra is running, you must stop the server and clear the data:

Doing this removes the default `cluster_name` (Test Cluster) from the system table. All nodes must use the same cluster name.

Package installations:

- a) Stop Cassandra:

```
$ sudo service cassandra stop
```

- b) Clear the data:

```
$ sudo rm -rf /var/lib/cassandra/data/system/*
```

Tarball installations:

- a) Stop Cassandra:

```
$ ps auwx | grep cassandra  
$ sudo kill pid
```

- b) Clear the data:

```
$ sudo rm -rf /var/lib/cassandra/data/system/*
```

4. Set the properties in the `cassandra.yaml` file for each node:

**Note:** After making any changes in the `cassandra.yaml` file, you must restart the node for the changes to take effect.

Properties to set:

- `num_tokens`: *recommended value: 256*
- `-seeds`: *internal IP address of each seed node*

Seed nodes do not **bootstrap**, which is the process of a new node joining an existing cluster. For new clusters, the bootstrap process on seed nodes is skipped.

- `listen_address`:  
If not set, Cassandra asks the system for the local address, the one associated with its hostname. In some cases Cassandra doesn't produce the correct address and you must specify the `listen_address`.
- `endpoint_snitch`: *name of snitch* (See [endpoint\\_snitch](#).) If you are changing snitches, see [Switching snitches](#).
- `auto_bootstrap`: `false` (Add this setting **only** when initializing a fresh cluster with no data.)

**Note:** If the nodes in the cluster are identical in terms of disk layout, shared libraries, and so on, you can use the same copy of the `cassandra.yaml` file on all of them.

Example:

```
cluster_name: 'MyCassandraCluster'  
num_tokens: 256  
seed_provider:  
  - class_name: org.apache.cassandra.locator.SimpleSeedProvider  
    parameters:  
      - seeds: "110.82.155.0,110.82.155.3"  
listen_address:  
rpc_address: 0.0.0.0  
endpoint_snitch: GossipingPropertyFileSnitch
```

- In the `cassandra-rackdc.properties` file, assign the data center and rack names you determined in the Prerequisites. For example:

```
# indicate the rack and dc for this node
dc=DC1
rack=RAC1
```

- After you have installed and configured Cassandra on all nodes, start the seed nodes one at a time, and then start the rest of the nodes.

**Note:** If the node has restarted because of automatic restart, you must first stop the node and clear the data directories, as described [above](#).

Package installations:

```
$ sudo service cassandra start
```

Tarball installations:

```
$ cd install_location
$ bin/cassandra
```

- To check that the ring is up and running, run:

Package installations:

```
$ nodetool status
```

Tarball installations:

```
$ cd install_location
$ bin/nodetool status
```

Each node should be listed and it's status and state should be UN (Up Normal).

```
paul@ubuntu:~/cassandra-2.1.0$ bin/nodetool status
Datacenter: datacenter1
=====
Status=Up/Down
--/ State=Normal/Leaving/Joining/Moving
-- Address          Load        Tokens      Owns    Host ID                               Rack
UN  10.194.171.160    53.98 KB    256         0.8%    a9fa31c7-f3c0-44d1-b8e7-a2628867840c rack1
UN  10.196.14.48      93.62 KB    256         9.9%    f5bb146c-db51-475c-a44f-9facf2f1ad6e rack1
UN  10.196.14.239    83.98 KB    256         8.2%    b8e6748f-ec11-410d-c94f-b8e7d88a28e7 rack1
...

```

The location of the `cassandra.yaml` file depends on the type of installation:

Package installations	<code>/etc/cassandra/cassandra.yaml</code>
Tarball installations	<code>install_location/resources/cassandra/conf/cassandra.yaml</code>

## Initializing a multiple node cluster (multiple data centers)

A deployment scenario for a Cassandra cluster with multiple data centers.

### About this task

This topic contains information for deploying a Cassandra cluster with multiple data centers. If you're new to Cassandra, and haven't set up a cluster, see [Cassandra and DataStax Enterprise Essentials](#) or [10 Minute Cassandra Walkthrough](#).

## Initializing a cluster

This example describes installing a six node cluster spanning two data centers. Each node is configured to use the [GossipingPropertyFileSnitch](#) (multiple rack aware) and 256 virtual nodes (vnodes).

In Cassandra, the term data center is a grouping of nodes. Data center is synonymous with replication group, that is, a grouping of nodes configured together for replication purposes.

### Before you begin

Each node must be correctly configured before starting the cluster. You must determine or perform the following before starting the cluster:

- A good understanding of how Cassandra works. Be sure to read at least [Understanding the architecture](#), [Data replication](#), and [Cassandra's rack feature](#).
- Install Cassandra on each node.
- Choose a name for the cluster.
- Get the IP address of each node.
- Determine which nodes will be seed nodes. **Do not make all nodes seed nodes.** Please read [Internode communications \(gossip\)](#).
- Determine the [snitch](#) and [replication strategy](#). The [GossipingPropertyFileSnitch](#) and [NetworkTopologyStrategy](#) are recommended for production environments.
- If using multiple data centers, determine a naming convention for each data center and rack, for example: DC1, DC2 or 100, 200 and RAC1, RAC2 or R101, R102. Choose the name carefully; renaming a data center is not possible.
- Other possible configuration settings are described in [cassandra.yaml configuration file](#) and property files such as `cassandra-rackdc.properties`.

### Procedure

1. Suppose you install Cassandra on these nodes:

```
node0 10.168.66.41 (seed1)
node1 10.176.43.66
node2 10.168.247.41
node3 10.176.170.59 (seed2)
node4 10.169.61.170
node5 10.169.30.138
```

**Note:** It is a best practice to have more than one seed node per data center.

2. If you have a firewall running in your cluster, you must open certain ports for communication between the nodes. See [Configuring firewall port access](#).
3. If Cassandra is running, you must stop the server and clear the data:

Doing this removes the default `cluster_name` (Test Cluster) from the system table. All nodes must use the same cluster name.

Package installations:

- a) Stop Cassandra:

```
$ sudo service cassandra stop
```

- b) Clear the data:

```
$ sudo rm -rf /var/lib/cassandra/data/system/*
```

Tarball installations:

- a) Stop Cassandra:

```
$ ps auwx | grep cassandra
$ sudo kill pid
```

b) Clear the data:

```
$ sudo rm -rf /var/lib/cassandra/data/system/*
```

4. Set the properties in the `cassandra.yaml` file for each node:

**Note:** After making any changes in the `cassandra.yaml` file, you must restart the node for the changes to take effect.

Properties to set:

- `num_tokens`: *recommended value: 256*
- `-seeds`: *internal IP address of each seed node*

Seed nodes do not **bootstrap**, which is the process of a new node joining an existing cluster. For new clusters, the bootstrap process on seed nodes is skipped.

- `listen_address`:

If not set, Cassandra asks the system for the local address, the one associated with its hostname. In some cases Cassandra doesn't produce the correct address and you must specify the `listen_address`.

- `endpoint_snitch`: *name of snitch* (See [endpoint\\_snitch](#).) If you are changing snitches, see [Switching snitches](#).
- `auto_bootstrap`: `false` (Add this setting **only** when initializing a fresh cluster with no data.)

**Note:** If the nodes in the cluster are identical in terms of disk layout, shared libraries, and so on, you can use the same copy of the `cassandra.yaml` file on all of them.

Example:

```
cluster_name: 'MyCassandraCluster'
num_tokens: 256
seed_provider:
  - class_name: org.apache.cassandra.locator.SimpleSeedProvider
    parameters:
      - seeds: "10.168.66.41,10.176.170.59"
listen_address:
endpoint_snitch: GossipingPropertyFileSnitch
```

**Note:** Include at least one node from *each* data center.

5. In the `cassandra-rackdc.properties` file, assign the data center and rack names you determined in the Prerequisites. For example:

#### Nodes 0 to 2

```
# indicate the rack and dc for this node
dc=DC1
rack=RAC1
```

#### Nodes 3 to 5

```
# indicate the rack and dc for this node
dc=DC2
rack=RAC1
```

6. After you have installed and configured Cassandra on all nodes, start the seed nodes one at a time, and then start the rest of the nodes.

**Note:** If the node has restarted because of automatic restart, you must first stop the node and clear the data directories, as described [above](#).

Package installations:

## Initializing a cluster

```
$ sudo service cassandra start
```

Tarball installations:

```
$ cd install_location
$ bin/cassandra
```

7. To check that the ring is up and running, run:

Package installations:

```
$ nodetool status
```

Tarball installations:

```
$ cd install_location
$ bin/nodetool status
```

Each node should be listed and its status and state should be UN (Up Normal).

```
paul@ubuntu:~/cassandra-2.1.0$ bin/nodetool status
Datacenter: datacenter1
=====
Status=Up/Down
|/ State=Normal/Leaving/Joining/Moving
--  Address            Load           Tokens  Owns    Host ID                               Rack
UN  10.194.171.160      53.98 KB      256     0.8%   a9fa31c7-f3c0-44d1-b8e7-a2628867840c rack1
UN  10.196.14.48        93.62 KB      256     9.9%   f5bb146c-db51-475c-a44f-9facf2f1ad6e rack1
UN  10.196.14.239      83.98 KB      256     8.2%   b8e6748f-ec11-410d-c94f-b8e7d88a28e7 rack1
..
```

The location of the `cassandra.yaml` file depends on the type of installation:

Package installations	<code>/etc/cassandra/cassandra.yaml</code>
Tarball installations	<code><i>install_location</i>/resources/cassandra/conf/cassandra.yaml</code>

# Security

Topics for securing Cassandra.

## Securing Cassandra

Cassandra provides various security features to the open source community.

Cassandra provides these security features to the open source community.

- **Client-to-node encryption**

Cassandra includes an optional, secure form of communication from a client machine to a database cluster. Client to server SSL ensures data in flight is not compromised and is securely transferred back/forth from client machines.

- **Authentication based on internally controlled login accounts/passwords**

Administrators can create users who can be authenticated to Cassandra database clusters using the CREATE USER command. Internally, Cassandra manages user accounts and access to the database cluster using passwords. User accounts may be altered and dropped using the [Cassandra Query Language \(CQL\)](#).

- **Object permission management**

Once authenticated into a database cluster using either internal authentication, the next security issue to be tackled is permission management. What can the user do inside the database? Authorization capabilities for Cassandra use the familiar GRANT/REVOKE security paradigm to manage object permissions.

## SSL encryption

Topics for using SSL in Cassandra.

### Client-to-node encryption

Client-to-node encryption protects data in flight from client machines to a database cluster using SSL (Secure Sockets Layer).

#### About this task

Client-to-node encryption protects data in flight from client machines to a database cluster using SSL (Secure Sockets Layer). It establishes a secure channel between the client and the coordinator node.

The location of the `cassandra.yaml` file depends on the type of installation:

Package installations	<code>/etc/cassandra/cassandra.yaml</code>
Tarball installations	<code>install_location/resources/cassandra/conf/cassandra.yaml</code>

#### Before you begin

All nodes must have all the relevant SSL certificates on all nodes. See [Preparing server certificates](#).

#### About this task

To enable client-to-node SSL, you must set the `client_encryption_options` in the `cassandra.yaml` file.

### Procedure

On each node under `client_encryption_options`:

- Enable encryption.
- Set the appropriate paths to your `.keystore` and `.truststore` files.
- Provide the required passwords. The passwords must match the passwords used when generating the keystore and truststore.
- To enable client certificate authentication, set `require_client_auth` to `true`. (Available starting with Cassandra 1.2.3.)

### Example

```
client_encryption_options:  
  enabled: true  
  keystore: conf/.keystore ## The path to your .keystore file  
  keystore_password: <keystore password> ## The password you used when  
    generating the keystore.  
  truststore: conf/.truststore  
  truststore_password: <truststore password>  
  require_client_auth: <true or false>
```

## Node-to-node encryption

Node-to-node encryption protects data transferred between nodes in a cluster, including gossip communications, using SSL (Secure Sockets Layer).

### About this task

Node-to-node encryption protects data transferred between nodes in a cluster, including gossip communications, using SSL (Secure Sockets Layer).

### Before you begin

All nodes must have all the relevant SSL certificates on all nodes. See [Preparing server certificates](#).

### About this task

To enable node-to-node SSL, you must set the `server_encryption_options` in the `cassandra.yaml` file.

The location of the `cassandra.yaml` file depends on the type of installation:

Package installations	<code>/etc/cassandra/cassandra.yaml</code>
Tarball installations	<code>install_location/resources/cassandra/conf/cassandra.yaml</code>

### Procedure

On each node under `server_encryption_options`:

- Enable `internode_encryption`.  
The available options are:
  - `all`
  - `none`
  - `dc`: Cassandra encrypts the traffic between the data centers.
  - `rack`: Cassandra encrypts the traffic between the racks.
- Set the appropriate paths to your `.keystore` and `.truststore` files.



- Provide the required passwords. The passwords must match the passwords used when generating the keystore and truststore.
- To enable client certificate authentication, set `require_client_auth` to `true`. (Available starting with Cassandra 1.2.3.)

### Example

```
server_encryption_options:
  internode_encryption: <internode_option>
  keystore: resources/dse/conf/.keystore
  keystore_password: <keystore password>
  truststore: resources/dse/conf/.truststore
  truststore_password: <truststore password>
  require_client_auth: <true or false>
```

## Using cqlsh with SSL encryption

Using a `cqlshrc` file with SSL encryption.

### About this task

Using a `cqlshrc` file means you don't have to override the `SSL_CERTFILE` environmental variables every time.

### Procedure

1. To run `cqlsh` with SSL encryption, create a `.cassandra/cqlshrc` file in your home or client program directory.

Sample files are available in the following directories:

- Package installations: `/etc/cassandra`
- Tarball installations: `install_location/conf`

2. Start `cqlsh` with the `--ssl` option.

```
$ cqlsh --ssl ## Package installations
$ install_location/bin/cqlsh -ssl ## Tarball installations
```

### Example

```
[authentication]
username = fred
password = !!bang!!$

[connection]
hostname = 127.0.0.1
port = 9042

[ssl]
certfile = ~/keys/cassandra.cert
validate = true ## Optional, true by default
userkey = ~/key.pem ## Provide when require_client_auth=true
usercert = ~/cert.pem ## Provide when require_client_auth=true

[certfiles] ## Optional section, overrides the default certfile in the
[ssl] section
192.168.1.3 = ~/keys/cassandra01.cert
192.168.1.4 = ~/keys/cassandra02.cert
```

**Note:** When `validate` is enabled, the host in the certificate is compared to the host of the machine that it is connected to. The SSL certificate must be provided either in the configuration file or as an environment variable. The environment variables (`SSL_CERTFILE` and `SSL_VALIDATE`) override any options set in this file.

### Preparing server certificates

Steps to generate SSL certificates for client-to-node encryption or node-to-node encryption.

#### About this task

How to generate SSL certificates for client-to-node encryption or node-to-node encryption. If you generate the certificates for one type of encryption, you do not need to generate them again for the other: the same certificates are used for both. All nodes must have all the relevant SSL certificates on all nodes. A keystore contains private keys. The truststore contains SSL certificates for each node and doesn't require signing by a trusted and recognized public certification authority.

#### Procedure

1. Generate the private and public key pair for the nodes of the cluster.

A prompt for the new keystore and key password appears.

2. Leave key password the same as the keystore password.
3. Repeat steps 1 and 2 on each node using a different alias for each one.

```
keytool -genkey -keyalg RSA -alias <cassandra_node0> -keystore .keystore
```

4. Export the public part of the certificate to a separate file and copy these certificates to all other nodes.

```
keytool -export -alias cassandra -file cassandranode0.cer -keystore .keystore
```

5. Add the certificate of each node to the truststore of each node, so nodes can verify the identity of other nodes.

```
keytool -import -v -trustcacerts -alias <cassandra_node0> -file <cassandra_node0>.cer -keystore .truststore
keytool -import -v -trustcacerts -alias <cassandra_nodel> -file <cassandra_nodel>.cer -keystore .truststore
. . .
```

6. Distribute the `.keystore` and `.truststore` files to all Cassandra nodes.
7. Make sure `.keystore` is readable only to the Cassandra daemon and not by any user of the system.

#### Adding new trusted users

Add new users when client certificate authentication is enabled.

#### About this task

How to add new users when client certificate authentication is enabled.

#### Before you begin

The client certificate authentication must be enabled (`require_client_auth=true`).

#### Procedure

1. Generate the certificate as described in [Client-to-node encryption](#).

2. Import the user's certificate into every node's truststore using keytool:

```
keytool -import -v -trustcacerts -alias <username> -file <certificate
file> -keystore .truststore
```

## Internal authentication

Topics for internal authentication.

### Internal authentication

Internal authentication is based on Cassandra-controlled login accounts and passwords.

Like [object permission management](#) using internal authorization, internal authentication is based on Cassandra-controlled login accounts and passwords. Internal authentication works for the following clients when you provide a user name and password to start up the client:

- Astyanax
- `cassandra-cli`
- `cqlsh`
- [DataStax drivers](#) - produced and certified by DataStax to work with Cassandra.
- Hector
- `ycassa`

Internal authentication stores usernames and bcrypt-hashed passwords in the `system_auth.credentials` table.

`PasswordAuthenticator` is an `IAuthenticator` implementation that you can use to configure Cassandra for internal authentication out-of-the-box.

### Configuring authentication

Steps for configuring authentication.

#### About this task

To configure Cassandra to use internal authentication, first make a change to the `cassandra.yaml` file and increase the replication factor of the `system_auth` keyspace, as described in this procedure. Next, start up Cassandra using the default user name and password (`cassandra/cassandra`), and start `cqlsh` using the same credentials. Finally, use these CQL statements to set up user accounts to authorize users to access the database objects:

- `ALTER USER`
- `CREATE USER`
- `DROP USER`
- `LIST USERS`

**Note:** To configure authorization, see [Configuring internal authorization](#).

The location of the `cassandra.yaml` file depends on the type of installation:

Package installations	<code>/etc/cassandra/cassandra.yaml</code>
Tarball installations	<code>install_location/resources/cassandra/conf/cassandra.yaml</code>

#### Procedure

1. Change the authenticator option in the `cassandra.yaml` file to `PasswordAuthenticator`.

## Security

By default, the authenticator option is set to AllowAllAuthenticator.

```
authenticator: PasswordAuthenticator
```

2. **Increase the replication factor** for the `system_auth` keyspace to N (number of nodes).

If you use the default, 1, and the node with the lone replica goes down, you will not be able to log into the cluster because the `system_auth` keyspace was not replicated.

3. Restart the Cassandra client.

The default **superuser** name and password that you use to start the client is stored in Cassandra.

```
<client startup string> -u cassandra -p cassandra
```

4. Start `cqlsh` using the superuser name and password.

```
./cqlsh -u cassandra -p cassandra
```

5. Create another superuser, not named `cassandra`. This step is optional but highly recommended.
6. Log in as that new superuser.
7. Change the `cassandra` user password to something long and incomprehensible, and then forget about it. It won't be used again.
8. Take away the `cassandra` user's superuser status.
9. Use the CQL statements listed previously to set up user accounts and then grant permissions to access the database objects.

## Logging in using `cqlsh`

How to create a `cqlshrc` file to avoid having enter credentials every time you launch `cqlsh`.

### About this task

Typically, after configuring authentication, you log into `cqlsh` using the `-u` and `-p` options to the `cqlsh` command. To avoid having enter credentials every time you launch `cqlsh`, you can create a `cqlshrc` file in the `.cassandra` directory, which is in your home directory. When present, this file passes default login information to `cqlsh`.

**Note:** Sample `cqlshrc` files are available in:

- Package installations: `/etc/cassandra`
- Tarball installations: `install_location/conf`

### Procedure

1. Open a text editor and create a file that specifies a user name and password.

```
[authentication]
username = fred
password = !!bang!!$
```

2. Save the file in your `home/.cassandra` directory and name it `cqlshrc`.
3. Set permissions on the file.

To protect database login information, ensure that the file is secure from unauthorized access.

## Internal authorization

Topics about internal authorization.

## Object permissions

Granting or revoking permissions to access Cassandra data.

Cassandra provides the familiar relational database GRANT/REVOKE paradigm to grant or revoke permissions to access Cassandra data. A **superuser** grants initial permissions, and subsequently a user may or may not be given the permission to grant/revoke permissions. Object permission management is based on internal authorization.

Read access to these system tables is implicitly given to every authenticated user because the tables are used by most Cassandra tools:

- system.schema\_keyspace
- system.schema\_columns
- system.schema\_columnfamilies
- system.local
- system.peers

## Configuring internal authorization

Steps for adding the CassandraAuthorizer.

### About this task

CassandraAuthorizer is one of many possible IAuthorizer implementations, and the one that stores permissions in the system\_auth.permissions table to support all authorization-related CQL statements. Configuration consists mainly of changing the authorizer option in the cassandra.yaml to use the CassandraAuthorizer.

**Note:** To configure authentication, see [Configuring authentication](#).

The location of the `cassandra.yaml` file depends on the type of installation:

Package installations	<code>/etc/cassandra/cassandra.yaml</code>
Tarball installations	<code>install_location/resources/cassandra/conf/cassandra.yaml</code>

### Procedure

1. In the `cassandra.yaml` file, comment out the default AllowAllAuthorizer and add the CassandraAuthorizer.

```
authorizer: CassandraAuthorizer
```

You can use any authenticator except AllowAll.

2. **Configure the replication factor** for the system\_auth keyspace to increase the replication factor to a number greater than 1.
3. Adjust the validity period for permissions caching by setting the `permissions_validity_in_ms` option in the `cassandra.yaml` file.  
Alternatively, disable permission caching by setting this option to 0.

### Results

CQL supports these authorization statements:

- GRANT
- LIST PERMISSIONS
- REVOKE

## Configuring firewall port access

Which ports to open when nodes are protected by a firewall.

If you have a firewall running on the nodes in your Cassandra cluster, you must open up the following ports to allow communication between the nodes, including certain Cassandra ports. If this isn't done, when you start Cassandra on a node, the node acts as a standalone database server rather than joining the database cluster.

**Table 2: Public ports**

Port number	Description
22	SSH port
8888	OpsCenter website. The opscenterd daemon listens on this port for HTTP requests coming directly from the browser.

**Table 3: Cassandra inter-node ports**

Port number	Description
7000	Cassandra inter-node cluster communication.
7001	Cassandra SSL inter-node cluster communication.
7199	Cassandra JMX monitoring port.

**Table 4: Cassandra client ports**

Port number	Description
9042	Cassandra client port.
9160	Cassandra client port (Thrift).

**Table 5: Cassandra OpsCenter ports**

Port number	Description
61620	OpsCenter monitoring port. The opscenterd daemon listens on this port for TCP traffic coming from the agent.
61621	OpsCenter agent port. The agents listen on this port for SSL traffic initiated by OpsCenter.

## Enabling JMX authentication

The default settings for Cassandra make JMX accessible only from localhost. To enable remote JMX connections, change the LOCAL\_JMX setting in `cassandra-env.sh`.

### About this task

The default settings for Cassandra make JMX accessible only from localhost. If you want to enable remote JMX connections, change the LOCAL\_JMX setting in `cassandra-env.sh` and enable authentication and/or ssl. After you enable JMX authentication, ensure that tools that use JMX, such as nodetool and DataStax OpsCenter, are configured to use authentication.

To use JMX authentication for OpsCenter, follow the steps in [Modifying OpsCenter cluster connections](#).

### Procedure

1. Open the `cassandra-env.sh` file for editing and update or add these lines:

```
JVM_OPTS="$JVM_OPTS -Dcom.sun.management.jmxremote.authenticate=true"
JVM_OPTS="$JVM_OPTS -Dcom.sun.management.jmxremote.password.file=/etc/cassandra/jmxremote.password"
```

If the LOCAL\_JMX setting is in your file:

```
LOCAL_JMX=no
```

2. Copy the `jmxremote.password.template` from `/jre_install_location/lib/management/` to `/etc/cassandra/` and rename it to `jmxremote.password`:

```
cp /<jre_install_dir/lib/management/jmxremote.password.template /etc/cassandra/jmxremote.password
```

3. Change the ownership of `jmxremote.password` to the user you run `cassandra` with and change permission to read only:

```
chown cassandra:cassandra /etc/cassandra/jmxremote.password
chmod 400 /etc/cassandra/jmxremote.password
```

4. Edit `jmxremote.password` and add the user and password for JMX-compliant utilities:

```
monitorRole QED
controlRole R&D
cassandra cassandrapassword
```

**Note:** This `cassandra` user and `cassandra` password is just an example. Specify the user and password for your environment.

5. Add the `cassandra` user with read and write permission to `/jre_install_location/lib/management/jmxremote.access`:

```
monitorRole readonly
cassandra readwrite
controlRole readwrite \
create javax.management.monitor.,javax.management.timer. \
unregister
```

6. Restart Cassandra.
7. Run `nodetool` with the `cassandra` user and password.

```
$ nodetool status -u cassandra -pw cassandra
```

### Results

If you run `nodetool` without user and password, you see an error similar to:

```
root@VM1 cassandra]# nodetool status
```

```
Exception in thread "main" java.lang.SecurityException: Authentication failed!
  Credentials required
  at
    com.sun.jmx.remote.security.JMXPluggableAuthenticator.authenticationFailure(Unknown
      Source)
  at com.sun.jmx.remote.security.JMXPluggableAuthenticator.authenticate(Unknown
      Source)
  at sun.management.jmxremote.ConnectorBootstrap
    $AccessFileCheckerAuthenticator.authenticate(Unknown Source)
  at javax.management.remote.rmi.RMIServerImpl.doNewClient(Unknown Source)
  at javax.management.remote.rmi.RMIServerImpl.newClient(Unknown Source)
  at sun.reflect.NativeMethodAccessorImpl.invoke0(Native Method)
  at sun.reflect.NativeMethodAccessorImpl.invoke(Unknown Source)
  at sun.reflect.DelegatingMethodAccessorImpl.invoke(Unknown Source)
  at java.lang.reflect.Method.invoke(Unknown Source)
  at sun.rmi.server.UnicastServerRef.dispatch(Unknown Source)
  at sun.rmi.transport.Transport$1.run(Unknown Source)
  at sun.rmi.transport.Transport$1.run(Unknown Source)
  at java.security.AccessController.doPrivileged(Native Method)
  at sun.rmi.transport.Transport.serviceCall(Unknown Source)
  at sun.rmi.transport.tcp.TCPTransport.handleMessages(Unknown Source)
  at sun.rmi.transport.tcp.TCPTransport$ConnectionHandler.run0(Unknown Source)
  at sun.rmi.transport.tcp.TCPTransport$ConnectionHandler.run(Unknown Source)
  at java.util.concurrent.ThreadPoolExecutor.runWorker(Unknown Source)
  at java.util.concurrent.ThreadPoolExecutor$Worker.run(Unknown Source)
  at java.lang.Thread.run(Unknown Source)
  at sun.rmi.transport.StreamRemoteCall.exceptionReceivedFromServer(Unknown
    Source)
  at sun.rmi.transport.StreamRemoteCall.executeCall(Unknown Source)
  at sun.rmi.server.UnicastRef.invoke(Unknown Source)
  at javax.management.remote.rmi.RMIServerImpl_Stub.newClient(Unknown Source)
  at javax.management.remote.rmi.RMIConnector.getConnection(Unknown Source)
  at javax.management.remote.rmi.RMIConnector.connect(Unknown Source)
  at javax.management.remote.JMXConnectorFactory.connect(Unknown Source)
  at org.apache.cassandra.tools.NodeProbe.connect(NodeProbe.java:146)
  at org.apache.cassandra.tools.NodeProbe.<init>(NodeProbe.java:116)
  at org.apache.cassandra.tools.NodeCmd.main(NodeCmd.java:1099)
```



# Database internals

Topics about the Cassandra database.

## Storage engine

A description about Cassandra's storage structure and engine.

Cassandra uses a storage structure similar to a Log-Structured Merge Tree, unlike a typical relational database that uses a B-Tree. Cassandra avoids reading before writing. Read-before-write, especially in a large distributed system, can produce stalls in read performance and other problems. For example, two clients read at the same time, one overwrites the row to make update A, and then the other overwrites the row to make update B, removing update A. Reading before writing also corrupts caches and increases IO requirements. To avoid a read-before-write condition, the storage engine groups inserts/updates to be made, and sequentially writes only the updated parts of a row in append mode. Cassandra never re-writes or re-reads existing data, and never overwrites the rows in place.

A log-structured engine that avoids overwrites and uses sequential IO to update data is essential for writing to hard disks (HDD) and solid-state disks (SSD). On HDD, writing randomly involves a higher number of seek operations than sequential writing. The seek penalty incurred can be substantial. Using sequential IO, and thereby avoiding **write amplification** and disk failure, Cassandra accommodates inexpensive, consumer SSDs extremely well.

## Separate table directories

Cassandra provides fine-grained control of table storage on disk.

Cassandra provides fine-grained control of table storage on disk, writing tables to disk using separate directories for each table. From the installation directory, data files are stored using this directory and file naming format on default tarball installations:

```
/data/data/ks1/cf1-5be396077b811e3a3ab9dc4b9ac088d/ks1-cf1-hc-1-Data.db
```

On packaged installations, the data files are stored in the same format, but in `/var/lib/cassandra/data` by default. In this example, `ks1` represents the keyspace name to distinguish the keyspace for streaming or bulk loading data. A hexadecimal string, `5be396077b811e3a3ab9dc4b9ac088d` in this example, is appended to table names to represent unique table IDs.

Cassandra creates a subdirectory for each table, which allows you to symlink a table to a chosen physical drive or data volume. This provides the capability to move very active tables to faster media, such as SSD's for better performance, and also divvy up tables across all attached storage devices for better I/O balance at the storage layer.

## Cassandra storage basics

Understanding how Cassandra stores data.

To manage and access data in Cassandra, it is important to understand how Cassandra stores data. The hinted handoff feature and Cassandra conformance and non-conformance to the ACID (atomic, consistent, isolated, durable) database properties are key concepts in this discussion. In Cassandra, consistency refers to how up-to-date and synchronized a row of data is on all of its replicas.

Client utilities and application programming interfaces (APIs) for developing applications for data storage and retrieval are available.

### The write path to compaction

Cassandra processes data at several stages on the write path.

Cassandra processes data at several stages on the write path, starting with the immediate logging of a write and ending in compaction:

- Logging data in the commit log
- Writing data to the memtable
- Flushing data from the memtable
- Storing data on disk in SSTables
- Compaction

#### Logging writes and memtable storage

When a write occurs, Cassandra stores the data in a structure in memory, the memtable, and also appends writes to the commit log on disk, providing configurable durability. The commit log receives every write made to a Cassandra node, and these  **durable writes**  survive permanently even after power failure. The memtable is a write-back cache of data partitions that Cassandra looks up by key. The memtable stores writes until reaching a limit, and then is flushed.

#### Flushing data from the memtable

When memtable contents exceed a  **configurable threshold** , the memtable data, which includes indexes, is put in a queue to be flushed to disk. You can configure the length of the queue by changing  `memtable_flush_queue_size`  in the  `cassandra.yaml` . If the data to be flushed exceeds the queue size, Cassandra blocks writes until the next flush succeeds. You can manually flush a table using the  `nodetool flush`  command. Typically, before restarting nodes, flushing the memtable is recommended to reduce commit log replay time. To flush the data, Cassandra sorts memtables by token and then writes the data to disk sequentially.

#### Storing data on disk in SSTables

Data in the commit log is purged after its corresponding data in the memtable is flushed to an SSTable.

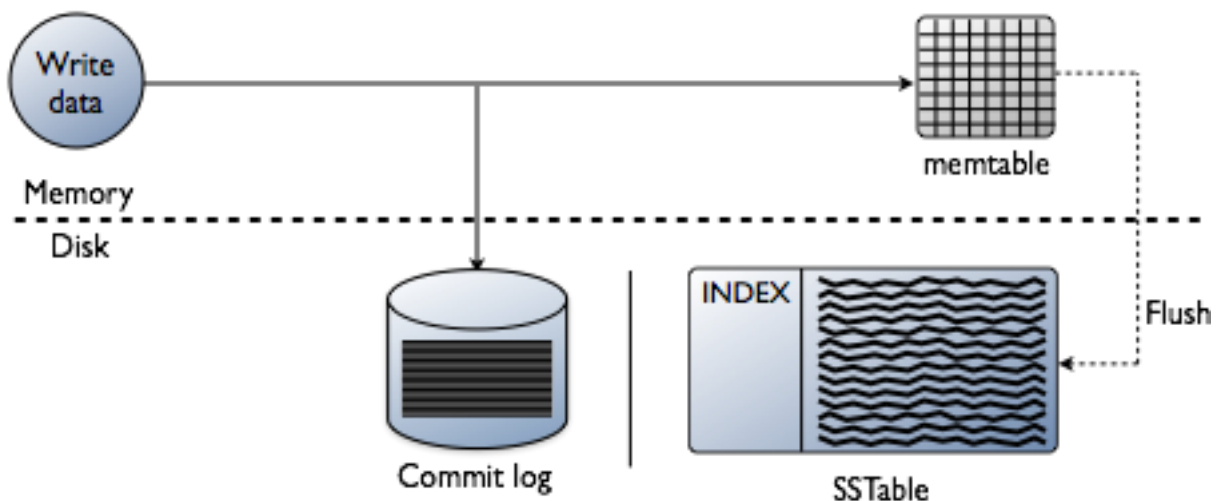

Memtables and SSTables are maintained per table. SSTables are immutable, not written to again after the memtable is flushed. Consequently, a partition is typically stored across multiple SSTable files.

For each SSTable, Cassandra creates these structures:

- Partition index  
A list of partition keys and the start position of rows in the data file (on disk)
- Partition summary (in memory)  
A sample of the partition index.
- Bloom filter

### Compaction

Periodic compaction is essential to a healthy Cassandra database because Cassandra does not insert/update in place. As inserts/updates occur, instead of overwriting the rows, Cassandra writes a new timestamped version of the inserted or updated data in another SSTable. Cassandra manages the accumulation of SSTables on disk using compaction.

Cassandra also does not delete in place because the SSTable is immutable. Instead, Cassandra marks data to be deleted using a **tombstone**. Tombstones exist for a configured time period defined by the **gc\_grace\_seconds** value set on the table.

During compaction, there is a temporary spike in disk space usage and disk I/O because the old and new SSTables co-exist. This diagram depicts the compaction process:

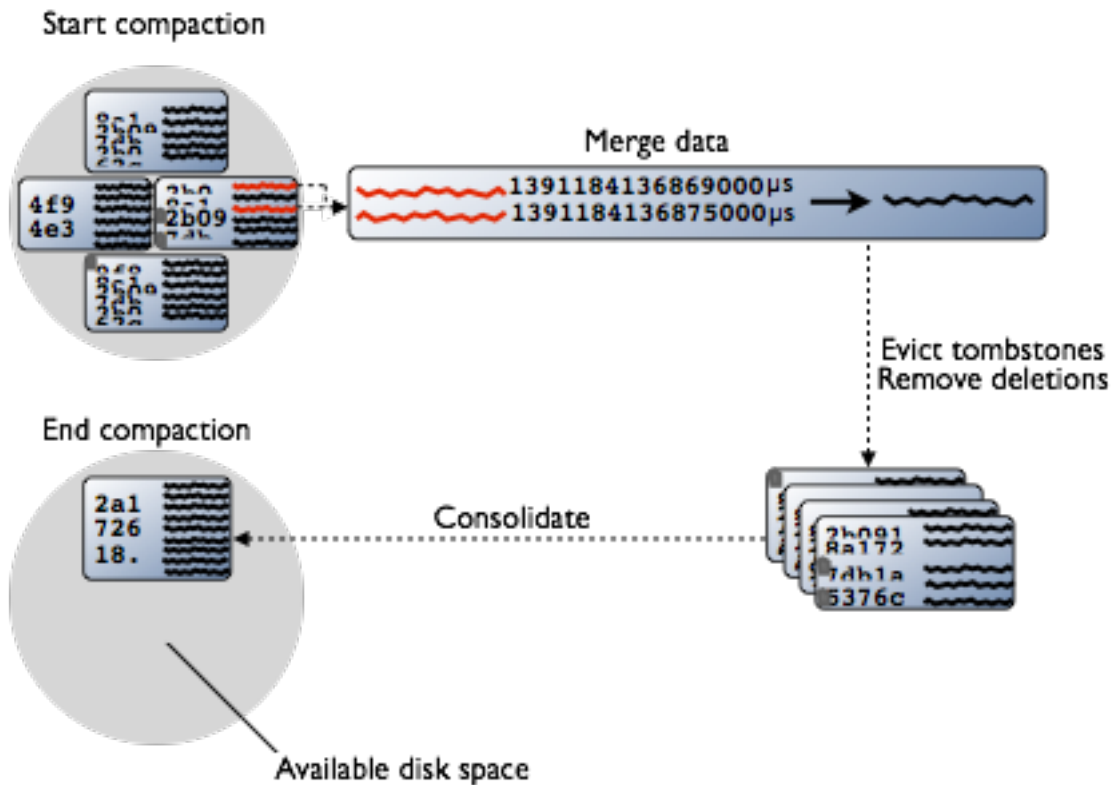

Compaction merges the data in each SSTable by partition key, selecting the latest data for storage based on its timestamp. Cassandra can merge the data performantly, without random IO, because rows are sorted by partition key within each SSTable. After evicting tombstones and removing deleted data, columns, and rows, the compaction process consolidates SSTables into a single file. The old SSTable files are deleted as soon as any pending reads finish using the files. Disk space occupied by old SSTables becomes available for reuse.

Cassandra 2.1 improves read performance after compaction by performing an incremental replacement of compacted SSTables. Instead of waiting for the entire compaction to finish and then throwing away the

## Database internals

old SSTable (and cache), Cassandra can read data directly from the new SSTable even before it finishes writing.

As data is written to the new SSTable and reads are directed to it, the corresponding data in the old SSTables is no longer accessed and is evicted from the page cache. Thus begins an incremental process of caching the new SSTable, while directing reads away from the old one. The dramatic cache miss is gone. Cassandra provides predictable high performance even under heavy load.

### Starting compaction

You can configure these types of compaction to run periodically:

- [SizeTieredCompactionStrategy](#)  
For write-intensive workloads
- [LeveledCompactionStrategy](#)  
For read-intensive workloads
- [DateTieredCompactionStrategy](#)  
For [time series data](#) and [expiring \(TTL\) data](#)

You can manually start compaction using the `nodetool compact` command.

For more information about compaction strategies, see [When to Use Leveled Compaction](#) and [Leveled Compaction in Apache Cassandra](#).

The location of the `cassandra.yaml` file depends on the type of installation:

Package installations	<code>/etc/cassandra/cassandra.yaml</code>
Tarball installations	<code>install_location/resources/cassandra/conf/cassandra.yaml</code>

## How Cassandra stores and distributes indexes

A brief description of how Cassandra stores and distributes indexes.

Internally, a Cassandra index is a data partition. In the example of [a music service](#), the `playlists` table includes an `artist` column and uses a compound partition key: `id` is the partition key and `song_order` is the clustering column.

```
CREATE TABLE playlists (  
  id uuid,  
  song_order int,  
  . . .  
  artist text,  
  PRIMARY KEY (id, song_order) );
```

As shown in the music service example, to filter the data based on the artist, create an index on `artist`. Cassandra uses the index to pull out the records in question. An attempt to filter the data before creating the index will fail because the operation would be very inefficient. A sequential scan across the entire `playlists` dataset would be required. After creating the `artist` index, Cassandra can filter the data in the `playlists` table by `artist`, such as `Fu Manchu`.

The partition is the unit of replication in Cassandra. In the music service example, partitions are distributed by hashing the playlist `id` and using the ring to locate the nodes that store the distributed data. Cassandra would generally store playlist information on different nodes, and to find all the songs by `Fu Manchu`, Cassandra would have to visit different nodes. To avoid these problems, each node indexes its own data.

This technique, however, does not guarantee trouble-free indexing, so know [when and when not to use an index](#).

## About index updates

A brief description about index updates.

As with relational databases, keeping indexes up to date is not free, so unnecessary indexes should be avoided. When a column is updated, the index is updated as well. If the old column value was still in the memtable, which typically occurs when updating a small set of rows repeatedly, Cassandra removes the corresponding obsolete index entry; otherwise, the old entry remains to be purged by compaction. If a read sees a stale index entry before compaction purges it, the reader thread invalidates it.

## The write path of an update

A brief description of the write path of an update.

Inserting a duplicate primary key is treated as an **upsert**. Eventually, the updates are streamed to disk using sequential I/O and stored in a new SSTable. During an update, Cassandra time-stamps and writes columns to disk using the **write path**. During the update, if multiple versions of the column exist in the memtable, Cassandra flushes only the newer version of the column to disk, as described in the **Compaction** section.

## About deletes

How Cassandra deletes data and why deleted data can reappear.

The way Cassandra deletes data differs from the way a relational database deletes data. A relational database might spend time scanning through data looking for expired data and throwing it away or an administrator might have to partition expired data by month, for example, to clear it out faster. Data in a Cassandra column can have an optional expiration date called TTL (time to live). Use CQL to **set the TTL** in seconds for data. Cassandra marks TTL data with a **tombstone** after the requested amount of time has expired. A tombstone exists for **gc\_grace\_seconds**. After data is marked with a tombstone, the data is automatically removed during the normal **compaction** process.

Facts about deleted data to keep in mind are:

- Cassandra does not immediately remove data marked for deletion from disk. The deletion occurs during compaction.
- If you use the **size-tiered** or **date-tiered** compaction strategy, you can drop data immediately by **manually starting the compaction process**. Before doing so, understand the documented disadvantages of the process.
- Deleted data can reappear if you do not run **node repair** routinely.

### Why deleted data can reappear

Marking data with a tombstone signals Cassandra to retry sending a delete request to a replica that was down at the time of delete. If the replica comes back up within the grace period of time, it eventually receives the delete request. However, if a node is down longer than the grace period, the node can miss the delete because the tombstone disappears after **gc\_grace\_seconds**. Cassandra always attempts to replay missed updates when the node comes back up again. After a failure, it is a best practice to run node repair to **repair inconsistencies** across all of the replicas when bringing a node back into the cluster. If the node doesn't come back within **gc\_grace\_seconds**, remove the node, wipe it, and bootstrap it again.

## About hinted handoff writes

How hinted handoff works and how it optimizes the cluster.

Hinted handoff is a Cassandra feature that optimizes the cluster **consistency** process and **anti-entropy** when a replica-owning node is not available, due to network issues or other problems, to accept a replica from a successful write operation. Hinted handoff is not a process that guarantees successful write

operations, except when a client application uses a consistency level of ANY. You [enable or disable hinted handoff](#) in the `cassandra.yaml` file.

### How hinted handoff works

During a write operation, when hinted handoff is enabled and consistency can be met, the coordinator stores a hint about dead replicas in the `local_system.hints` table under either of these conditions:

- A replica node for the row is known to be down ahead of time.
- A replica node does not respond to the write request.

When the cluster cannot meet the consistency level specified by the client, Cassandra does not store a hint.

A hint indicates that a write needs to be replayed to one or more unavailable nodes. The hint consists of:

- The location of the replica that is down
- Version metadata
- The actual data being written

By default, hints are saved for three hours after a replica fails because if the replica is down longer than that, it is likely permanently dead. You can configure this interval of time using the `max_hint_window_in_ms` property in the `cassandra.yaml` file. If the node recovers after the save time has elapsed, run a repair to re-replicate the data written during the down time.

After a node discovers from [gossip](#) that a node for which it holds hints has recovered, the node sends the data row corresponding to each hint to the target. Additionally, the node checks every ten minutes for any hints for writes that timed out during an outage too brief for the failure detector to notice through gossip.

For example, in a cluster of two nodes, A and B, having a replication factor (RF) of 1, each row is stored on one node. Suppose node A is down while we write row K to it with consistency level of one. The write fails because reads always reflect the most recent write when:

$W + R > \text{replication factor}$

where  $W$  is the number of nodes to block for writes and  $R$  is the number of nodes to block for reads. Cassandra does not write a hint to B and call the write good because Cassandra cannot read the data at any consistency level until A comes back up and B forwards the data to A.

In a cluster of three nodes, A (the coordinator), B, and C, each row is stored on two nodes in a keyspace having a replication factor of 2. Suppose node C goes down. The client writes row K to node A. The coordinator, replicates row K to node B, and writes the hint for downed node C to node A.

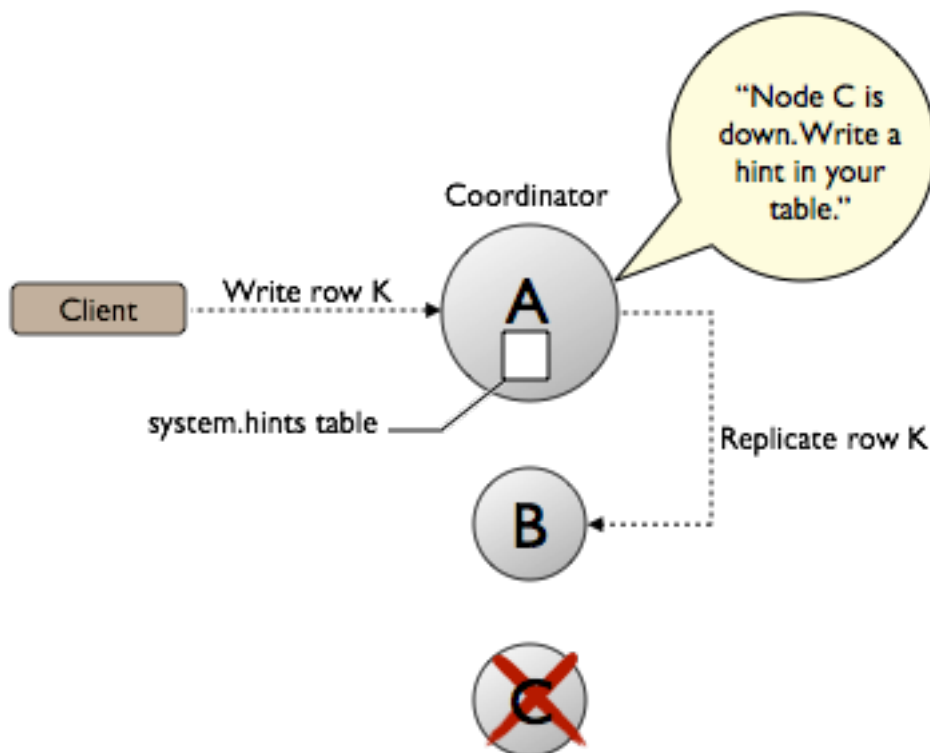

Cassandra, configured with a consistency level of ONE, calls the write good because Cassandra can read the data on node B. When node C comes back up, node A reacts to the hint by forwarding the data to node C. For more information about how hinted handoff works, see "[Modern hinted handoff](#)" by Jonathan Ellis.

### Extreme write availability

For applications that want Cassandra to accept writes even when all the normal replicas are down, when not even consistency level ONE can be satisfied, Cassandra provides consistency level ANY. ANY guarantees that the write is durable and will be readable after an appropriate replica target becomes available and receives the hint replay.

### Performance

By design, hinted handoff inherently forces Cassandra to continue performing the same number of writes even when the cluster is operating at reduced capacity. Pushing your cluster to maximum capacity with no allowance for failures is a bad idea.

Hinted handoff is designed to minimize the extra load on the cluster.

All hints for a given replica are stored under a single [partition key](#), so replaying hints is a simple sequential read with minimal performance impact.

If a replica node is overloaded or unavailable, and the failure detector has not yet marked it down, then expect most or all writes to that node to fail after the timeout triggered by [write\\_request\\_timeout\\_in\\_ms](#), which defaults to 10 seconds.

If this happens on many nodes at once this could become substantial memory pressure on the coordinator. So the coordinator tracks how many hints it is currently writing, and if this number gets too high it will temporarily refuse writes ([withOverloadedException](#)) whose replicas include the misbehaving nodes.



## Database internals

### Removal of hints

When removing a node from the cluster by decommissioning the node or by using the `nodetool removemode` command, Cassandra automatically removes hints targeting the node that no longer exists. Cassandra also removes hints for dropped tables.

### Scheduling repair weekly

At first glance, it seems that hinted handoff eliminates the need for repair, but this is not true because hardware failure is inevitable and has the following ramifications:

- Loss of the historical data necessary to tell the rest of the cluster exactly what data is missing.
- Loss of hints-not-yet-replayed from requests that the failed node coordinated.

The location of the `cassandra.yaml` file depends on the type of installation:

Package installations	<code>/etc/cassandra/cassandra.yaml</code>
Tarball installations	<code>install_location/resources/cassandra/conf/cassandra.yaml</code>

## Reads

How reads work and factors affecting them.

### About reads

How Cassandra combines results from the active memtable and potentially multiple SSTables to satisfy a read.

To satisfy a read, Cassandra must combine results from the active memtable and potentially multiple SSTables.

First, Cassandra checks the **Bloom filter**. Each SSTable has a Bloom filter associated with it that checks the probability of having any data for the requested partition in the SSTable before doing any disk I/O.

If the Bloom filter does not rule out the SSTable, Cassandra checks the **partition key cache** and takes one of these courses of action:

- If an index entry is found in the cache:
  - Cassandra goes to the compression offset map to find the compressed block having the data.
  - Fetches the compressed data on disk and returns the result set.
- If an index entry is not found in the cache:
  - Cassandra searches the **partition summary** to determine the approximate location on disk of the index entry.
  - Next, to fetch the index entry, Cassandra hits the disk for the first time, performing a single seek and a sequential read of columns (a range read) in the SSTable if the columns are contiguous.
  - Cassandra goes to the compression offset map to find the compressed block having the data.
  - Fetches the compressed data on disk and returns the result set.



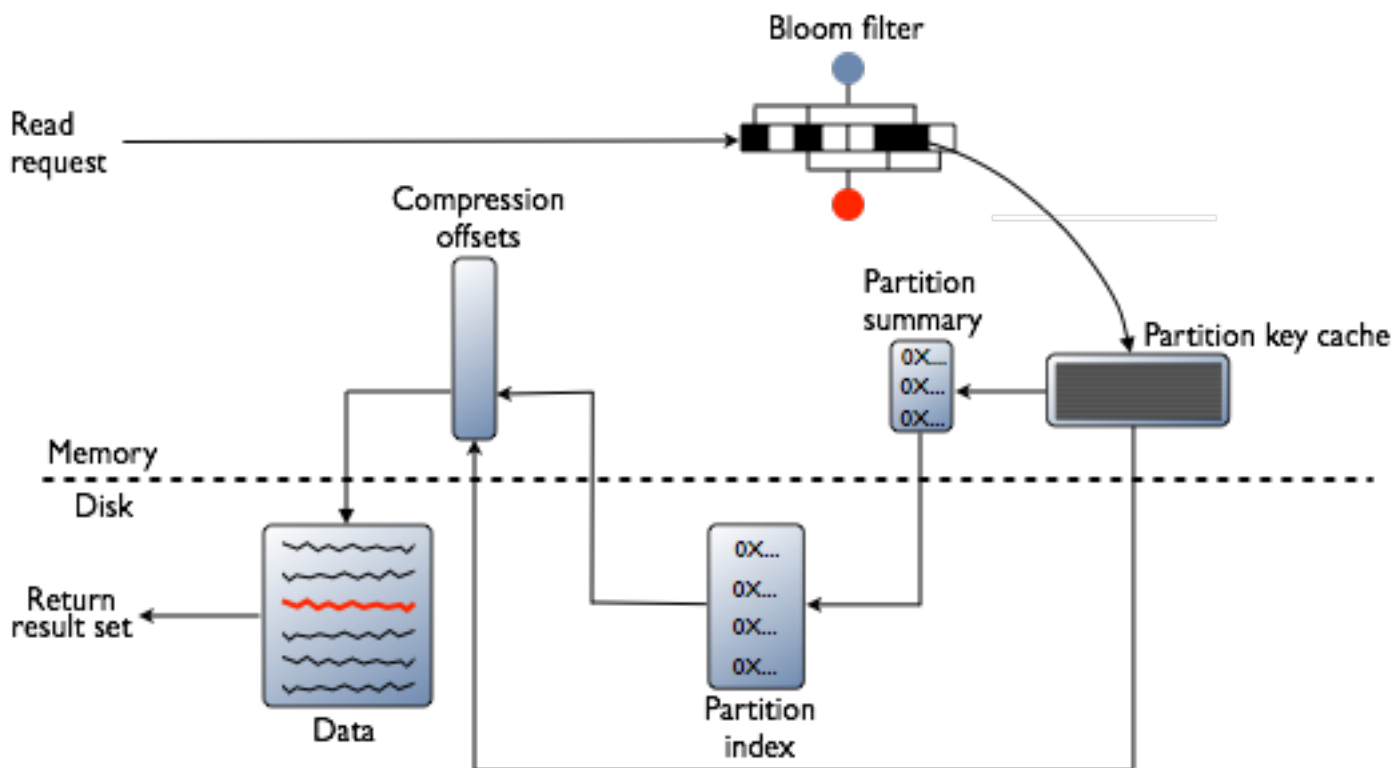

## How off-heap components affect reads

Factors for increasing the data handling capacity per node.

To increase the data handling capacity per node, Cassandra keeps these components off-heap:

- Bloom filter
- Compression offsets map
- Partition summary

Of the components in memory, only the partition key cache is a fixed size. Other components grow as the data set grows.

### Bloom filter

The Bloom filter grows to approximately 1-2 GB per billion partitions. In the extreme case, you can have one partition per row, so you can easily have billions of these entries on a single machine. The Bloom filter is tunable if you want to trade memory for performance.

### Partition summary

By default, the partition summary is a sample of the partition index. You configure sample frequency by changing the `index_interval` property in the [table definition](#), also if you want to trade memory for performance.

### Compression offsets

The compression offset map grows to 1-3 GB per terabyte compressed. The more you compress data, the greater number of compressed blocks you have and the larger the compression offset table. Compression is enabled by default even though going through the compression offset map consumes CPU resources. Having compression enabled makes the page cache more effective, and typically, almost always pays off.

### Reading from a partition

A brief description about reading from a partition.

Within a partition, all rows are not equally expensive to query. The very beginning of the partition—the first rows, **clustered by your key definition**—is slightly less expensive to query because there is no need to consult the partition-level index.

### How write patterns affect reads

A brief description about how write patterns affect reads.

The type of **compaction strategy** Cassandra performs on your data is configurable and can significantly affect read performance. Using the `SizeTieredCompactionStrategy` or `DateTieredCompactionStrategy` tends to cause data fragmentation when rows are frequently updated. The `LeveledCompactionStrategy` (LCS) was designed to prevent fragmentation under this condition. For more information about LCS, see the article, *Leveled Compaction in Apache Cassandra*.

### How the row cache affects reads

A brief description and illustration about how the row cache affects reads.

Typical of any database, reads are fastest when the most in-demand data (or *hot* working set) fits into memory. Although all modern storage systems rely on some form of caching to allow for fast access to hot data, not all of them degrade gracefully when the cache capacity is exceeded and disk I/O is required. Cassandra's read performance benefits from **built-in caching**, shown in the following diagram.

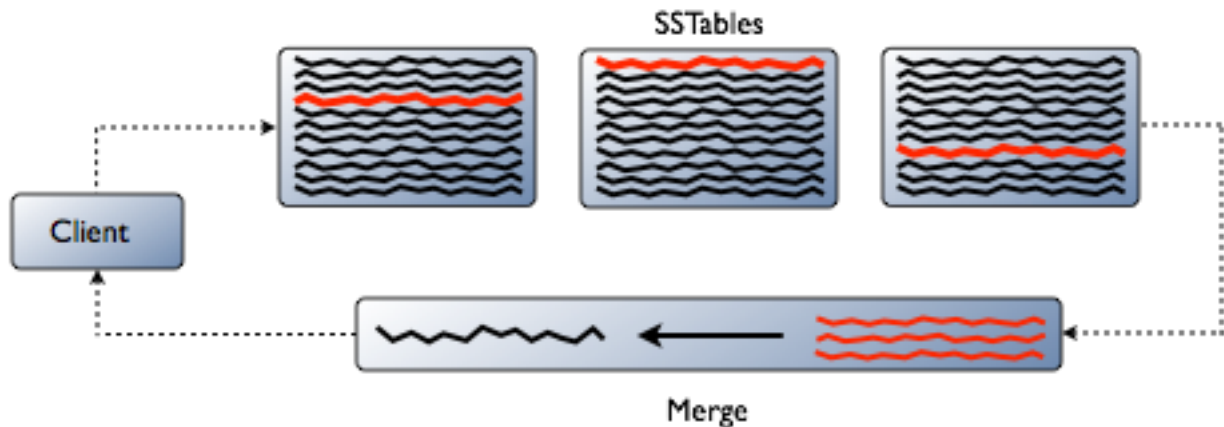

The red lines in the SSTables in this diagram are fragments of a row that Cassandra needs to combine to give the user the requested results. Cassandra caches the merged value, not the raw row fragments. That saves some CPU and disk I/O.

The row cache is not write-through. If a write comes in for the row, the cache for it is invalidated and is not cached again until it is read.

For rows that are accessed frequently, Cassandra 2.1 has improved the built-in partition key cache and an optional row cache.

### About transactions and concurrency control

A brief description about transactions and concurrency control.

Cassandra does not use RDBMS ACID transactions with rollback or locking mechanisms, but instead offers atomic, isolated, and durable transactions with eventual/tunable consistency that lets the user decide how strong or eventual they want each transaction's consistency to be.

As a non-relational database, Cassandra does not support joins or foreign keys, and consequently does not offer consistency in the ACID sense. For example, when moving money from account A to B the total in the accounts does not change. Cassandra supports atomicity and isolation at the row-level, but trades transactional isolation and atomicity for high availability and fast write performance. Cassandra writes are durable.

## Atomicity

Everything in a transaction succeeds or the entire transaction is rolled back.

In Cassandra, a write is atomic at the partition-level, meaning inserting or updating columns in a row is treated as one write operation. A delete operation is also performed atomically. By default, all operations in a batch are performed atomically. Cassandra uses a batch log to ensure all operations in a batch are applied atomically. There is a performance penalty for batch atomicity when a batch spans multiple partitions. If you do not want to incur this penalty, use the **UNLOGGED option**. Using UNLOGGED makes the batch operation atomic only within a single partition.

For example, if using a write consistency level of QUORUM with a replication factor of 3, Cassandra will replicate the write to all nodes in the cluster and wait for acknowledgement from two nodes. If the write fails on one of the nodes but succeeds on the other, Cassandra reports a failure to replicate the write on that node. However, the replicated write that succeeds on the other node is not automatically rolled back.

Cassandra uses timestamps to determine the most recent update to a column. Depending on the version of the Native CQL Protocol, the timestamp is provided by either the client application or the server. The latest timestamp always wins when requesting data, so if multiple client sessions update the same columns in a row concurrently, the most recent update is the one seen by readers.

**Important:** Native CQL Protocol V3 supports client-side timestamps. Be sure to check your client's documentation to ensure that it generates client-side timestamps and that this feature is activated.

## Consistency

A transaction cannot leave the database in an inconsistent state. Cassandra offers different types of consistency.

Cassandra offers two consistency types:

- **Tunable consistency**

Availability and consistency can be tuned, and can be strong in the **CAP** sense--data is made consistent across all the nodes in a distributed database cluster.

- **Linearizable consistency**

In ACID terms, linearizable consistency is a serial (immediate) isolation level for **lightweight transactions**.

In Cassandra, there are no locking or transactional dependencies when concurrently updating multiple rows or tables. Tuning availability and consistency always gives you partition tolerance. A user can pick and choose on a per operation basis how many nodes must receive a DML command or respond to a SELECT query.

For in-depth information about this new consistency level, see the article, *Lightweight transactions in Cassandra*.

To support linearizable consistency, a **consistency level of SERIAL** has been added to Cassandra. **Additions to CQL** have been made to support lightweight transactions.

## Isolation

Transactions cannot interfere with each other.

In early versions of Cassandra, it was possible to see partial updates in a row when one user was updating the row while another user was reading that same row. For example, if one user was writing a row with two

## Database internals

thousand columns, another user could potentially read that same row and see some of the columns, but not all of them if the write was still in progress.

Full row-level isolation is in place, which means that writes to a row are isolated to the client performing the write and are not visible to any other user until they are complete. Delete operations are performed in isolation. All updates in a batch operation belonging to a given partition key are performed in isolation.

## Durability

Completed transactions persist in the event of crashes or server failure.

Writes in Cassandra are durable. All writes to a replica node are recorded both in memory and in a commit log on disk before they are acknowledged as a success. If a crash or server failure occurs before the memtables are flushed to disk, the commit log is replayed on restart to recover any lost writes. In addition to the local durability (data immediately written to disk), the replication of data on other nodes strengthens durability.

You can manage the local durability to suit your needs for consistency using the `commitlog_sync` option in the `cassandra.yaml` file. Set the option to either `periodic` or `batch`.

The location of the `cassandra.yaml` file depends on the type of installation:

Package installations	<code>/etc/cassandra/cassandra.yaml</code>
Tarball installations	<code>install_location/resources/cassandra/conf/cassandra.yaml</code>

## Lightweight transactions

A description about lightweight transactions and when to use them.

Lightweight transactions with linearizable consistency ensure transaction isolation level similar to the serializable level offered by RDBMS's. They are also known as compare and set transactions. You use lightweight transactions instead of durable transactions with eventual/tunable consistency for situations that require nodes in the distributed system to agree on changes to data. For example, two users attempting to create a unique user account in the same cluster could overwrite each other's work. Using a lightweight transaction, the nodes can agree to create only one account.

Cassandra implements lightweight transactions by extending the Paxos consensus protocol, which is based on a quorum-based algorithm. Using this protocol, a distributed system can agree on proposed data additions/modifications without the need for a master database or two-phase commit.

You use extensions in CQL for lightweight transactions.

You can use an `IF` clause in a number of CQL statements, such as `INSERT`, for lightweight transactions. For example, to ensure that an insert into a new accounts table is unique for a new customer, use the `IF NOT EXISTS` clause:

```
INSERT INTO customer_account (customerID, customer_email)
VALUES ('LauraS', 'lauras@gmail.com')
IF NOT EXISTS;
```

DML modifications you make using `UPDATE` can also make use of the `IF` clause by comparing one or more columns to various values:

```
UPDATE customer_account
SET customer_email='laurass@gmail.com'
IF customerID='LauraS';
```

Cassandra 2.1.1 and later support non-equal conditions for lightweight transactions. You can use `<`, `<=`, `>`, `>=`, `!=` and `IN` operators in `WHERE` clauses to query lightweight tables. Behind the scenes, Cassandra is making four round trips between a node proposing a lightweight transaction and any needed replicas

in the cluster to ensure proper execution so performance is affected. Consequently, reserve lightweight transactions for those situations where they are absolutely necessary; Cassandra's normal eventual consistency can be used for everything else.

A **SERIAL consistency level** allows reading the current (and possibly uncommitted) state of data without proposing a new addition or update. If a SERIAL read finds an uncommitted transaction in progress, Cassandra performs a **read repair** as part of the commit.

## Data consistency

Topics about how up-to-date and synchronized a row of data is on all replicas.

### About data consistency

An introduction to how Cassandra extends eventual consistency with tunable consistency.

Consistency refers to how up-to-date and synchronized a row of Cassandra data is on all of its replicas. Cassandra extends the concept of **eventual consistency** by offering tunable consistency. Tunable consistency means for any given read or write operation, the client application decides how consistent the requested data must be.

Even at low consistency levels, Cassandra writes to all replicas of the partition key, even replicas in other data centers. The consistency level determines only the number of replicas that need to acknowledge the write success to the client application. Typically, a client specifies a consistency level that is less than the replication factor specified by the keyspace. This practice ensures that the coordinating server node reports the write successful even if some replicas are down or otherwise not responsive to the write.

The read consistency level specifies how many replicas must respond to a read request before returning data to the client application. Cassandra checks the specified number of replicas for data to satisfy the read request.

The CQL documentation contains a **tutorial** comparing consistency levels using cqlsh tracing.

### About built-in consistency repair features

Built-in repair utilities to ensure that data remains consistent across replicas.

You can use these built-in repair utilities to ensure that data remains consistent across replicas.

- **Read repair**
- **Hinted handoff**
- **Anti-entropy node repair**

### Configuring data consistency

Consistency levels in Cassandra can be configured to manage availability versus data accuracy.

Consistency levels in Cassandra can be configured to manage availability versus data accuracy. You can configure consistency on a cluster, data center, or individual I/O operation basis. Consistency among participating nodes can be set globally and also controlled on a per-operation basis (for example insert or update) using Cassandra's drivers and client libraries.

### Write consistency levels

This table describes the write consistency levels in strongest-to-weakest order.

Table 6: Write Consistency Levels

Level	Description	Usage
ALL	A write must be written to the <b>commit log and memtable</b> on all replica nodes in the cluster for that partition.	Provides the highest consistency and the lowest availability of any other level.
EACH_QUORUM	Strong consistency. A write must be written to the <b>commit log and memtable</b> on a quorum of replica nodes in <i>all data centers</i> .	Used in multiple data center clusters to strictly maintain consistency at the same level in each data center. For example, choose this level if you want a read to fail when a data center is down and the QUORUM cannot be reached on that data center.
QUORUM	A write must be written to the <b>commit log and memtable</b> on a quorum of replica nodes.	Provides strong consistency if you can tolerate some level of failure.
LOCAL_QUORUM	Strong consistency. A write must be written to the <b>commit log and memtable</b> on a quorum of replica nodes in the same data center as the <b>coordinator node</b> . Avoids latency of inter-data center communication.	Used in multiple data center clusters with a rack-aware replica placement strategy ( <b>NetworkTopologyStrategy</b> ) and a properly configured snitch. Fails when using <b>SimpleStrategy</b> . Use to maintain consistency locally (within the single data center).
ONE	A write must be written to the <b>commit log and memtable</b> of at least one replica node.	Satisfies the needs of most users because consistency requirements are not stringent.
TWO	A write must be written to the <b>commit log and memtable</b> of at least two replica nodes.	Similar to ONE.
THREE	A write must be written to the <b>commit log and memtable</b> of at least three replica nodes.	Similar to TWO.
LOCAL_ONE	A write must be sent to, and successfully acknowledged by, at least one replica node in the local datacenter.	In a multiple data center clusters, a consistency level of ONE is often desirable, but cross-DC traffic is not. LOCAL_ONE accomplishes this. For security and quality reasons, you can use this consistency level in an offline datacenter to prevent automatic connection to online nodes in other data centers if an offline node goes down.
ANY	A write must be written to at least one node. If all replica nodes for the given partition key are down, the write can still succeed after a <b>hinted handoff</b> has been written. If all replica nodes are down at write time, an ANY write is not readable until the replica nodes for that partition have recovered.	Provides low latency and a guarantee that a write never fails. Delivers the lowest consistency and highest availability.
SERIAL	Achieves <b>linearizable consistency</b> for lightweight transactions by preventing unconditional updates.	You cannot configure this level as a normal consistency level, configured at the driver level using the consistency level field. You configure this level using the serial

Level	Description	Usage
		consistency field as part of the <b>native protocol operation</b> . See failure scenarios.
LOCAL_SERIAL	Same as SERIAL but confined to the data center. A write must be written conditionally to the <b>commit log and memtable</b> on a quorum of replica nodes in the same data center.	Same as SERIAL. Used for disaster recovery. See failure scenarios.

### SERIAL and LOCAL\_SERIAL write failure scenarios

If one of three nodes is down, the Paxos commit fails under the following conditions:

- CQL query-configured consistency level of ALL
- Driver-configured serial consistency level of SERIAL
- Replication factor of 3

A WriteTimeout with a WriteType of CAS occurs and further reads do not see the write. If the node goes down in the middle of the operation instead of before the operation started, the write is committed, the value is written to the live nodes, and a WriteTimeout with a WriteType of SIMPLE occurs.

Under the same conditions, if two of the nodes are down at the beginning of the operation, the Paxos commit fails and nothing is committed. If the two nodes go down after the Paxos proposal is accepted, the write is committed to the remaining live nodes and written there, but a WriteTimeout with WriteType SIMPLE is returned.

### Read consistency levels

This table describes read consistency levels in strongest-to-weakest order.

**Table 7: Read Consistency Levels**

Level	Description	Usage
ALL	Returns the record after all replicas have responded. The read operation will fail if a replica does not respond.	Provides the highest consistency of all levels and the lowest availability of all levels.
EACH_QUORUM	Not supported for reads.	Not supported for reads.
QUORUM	Returns the record after a quorum of replicas has responded from any <b>data center</b> .	Ensures strong consistency if you can tolerate some level of failure.
LOCAL_QUORUM	Returns the record after a quorum of replicas in the current data center as the <b>coordinator node</b> has reported. Avoids latency of inter-data center communication.	Used in multiple data center clusters with a rack-aware replica placement strategy ( <code>NetworkTopologyStrategy</code> ) and a properly configured snitch. Fails when using <code>SimpleStrategy</code> .
ONE	Returns a response from the closest replica, as determined by the <b>snitch</b> . By default, a <b>read repair</b> runs in the background to make the other replicas consistent.	Provides the highest availability of all the levels if you can tolerate a comparatively high probability of stale data being read. The replicas contacted for reads may not always have the most recent write.
TWO	Returns the most recent data from two of the closest replicas.	Similar to ONE.



Level	Description	Usage
THREE	Returns the most recent data from three of the closest replicas.	Similar to TWO.
LOCAL_ONE	Returns a response from the closest replica in the local data center.	Same usage as described in the table about write consistency levels.
SERIAL	Allows reading the current (and possibly <b>uncommitted</b> ) state of data without proposing a new addition or update. If a SERIAL read finds an uncommitted transaction in progress, it will commit the transaction as part of the read. Similar to QUORUM.	To read the latest value of a column after a user has invoked a <b>lightweight transaction</b> to write to the column, use SERIAL. Cassandra then checks the inflight lightweight transaction for updates and, if found, returns the latest data.
LOCAL_SERIAL	Same as SERIAL, but confined to the data center. Similar to LOCAL_QUORUM.	Used to achieve <b>linearizable consistency</b> for lightweight transactions.

### About the QUORUM levels

The QUORUM level writes to the number of nodes that make up a quorum. A quorum is calculated, and then rounded down to a whole number, as follows:

$$\text{quorum} = (\text{sum\_of\_replication\_factors} / 2) + 1$$

The sum of all the `replication_factor` settings for each data center is the `sum_of_replication_factors`.

$$\text{sum\_of\_replication\_factors} = \text{datacenter1\_RF} + \text{datacenter2\_RF} + \dots + \text{datacentern\_RF}$$

Examples:

- Using a replication factor of 3, a quorum is 2 nodes. The cluster can tolerate 1 replica down.
- Using a replication factor of 6, a quorum is 4. The cluster can tolerate 2 replicas down.
- In a two data center cluster where each data center has a replication factor of 3, a quorum is 4 nodes. The cluster can tolerate 2 replica nodes down.
- In a five data center cluster where two data centers have a replication factor of 3 and three data centers have a replication factor of 2, a quorum is 6 nodes.

The more data centers, the higher number of replica nodes need to respond for a successful operation.

If consistency is a top priority, you can ensure that a read always reflects the most recent write by using the following formula:

$$(\text{nodes\_written} + \text{nodes\_read}) > \text{replication\_factor}$$

For example, if your application is using the QUORUM consistency level for both write and read operations and you are using a replication factor of 3, then this ensures that 2 nodes are always written and 2 nodes are always read. The combination of nodes written and read (4) being greater than the replication factor (3) ensures strong read consistency.

Similar to QUORUM, the LOCAL\_QUORUM level is calculated based on the replication factor of the same data center as the coordinator node. That is, even if the cluster has more than one data center, the quorum is calculated only with local replica nodes.

In EACH\_QUORUM, every data center in the cluster must reach a quorum based on that data center's replication factor in order for the read or write request to succeed. That is, for every data center in the



cluster a quorum of replica nodes must respond to the coordinator node in order for the read or write request to succeed.

### Configuring client consistency levels

You can use a new cqlsh command, `CONSISTENCY`, to set the consistency level for queries from the current cqlsh session. The `WITH CONSISTENCY` clause has been removed from CQL commands. You set the consistency level programmatically (at the driver level). For example, call `QueryBuilder.insertInto` with a `setConsistencyLevel` argument. The consistency level defaults to `ONE` for all write and read operations.

## Read requests

The three types of read requests that a coordinator node can send to a replica.

There are three types of read requests that a `coordinator` can send to a replica:

- A direct read request
- A digest request
- A background read repair request

The coordinator node contacts one replica node with a direct read request. Then the coordinator sends a digest request to a number of replicas determined by the `consistency level` specified by the client. The digest request checks the data in the replica node to make sure it is up to date. Then the coordinator sends a digest request to all remaining replicas. If any replica nodes have out of date data, a background read repair request is sent. Read repair requests ensure that the requested row is made consistent on all replicas.

For a digest request the coordinator first contacts the replicas specified by the consistency level. The coordinator sends these requests to the replicas that are currently responding the fastest. The nodes contacted respond with a digest of the requested data; if multiple nodes are contacted, the rows from each replica are compared in memory to see if they are consistent. If they are not, then the replica that has the most recent data (based on the timestamp) is used by the coordinator to forward the result back to the client.

To ensure that all replicas have the most recent version of frequently-read data, the coordinator also contacts and compares the data from all the remaining replicas that own the row in the background. If the replicas are inconsistent, the coordinator issues writes to the out-of-date replicas to update the row to the most recent values. This process is known as `read repair`. Read repair can be configured per table for non-`QUORUM` consistency levels (using `read_repair_chance`), and is enabled by default.

For illustrated examples of read requests, see the [examples of read consistency levels](#).

### Rapid read protection using `speculative_retry`

Rapid read protection allows Cassandra to still deliver read requests when the originally selected replica nodes are either down or taking too long to respond. If the table has been configured with the `speculative_retry` property, the coordinator node for the read request will retry the request with another replica node if the original replica node exceeds a configurable timeout value to complete the read request.

## Database internals

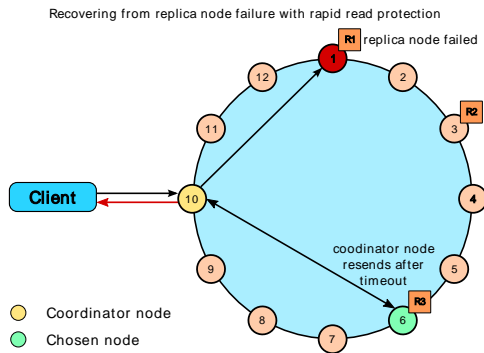

### Examples of read consistency levels

Read request examples with different consistency levels.

The following diagrams show examples of read requests using these consistency levels:

- QUORUM in a single data center
- ONE in a single data center
- QUORUM in two data centers
- LOCAL\_QUORUM in two data centers
- ONE in two data centers
- LOCAL\_ONE in two data centers

Rapid read protection diagram shows how the speculative retry table property affects consistency.

### A single data center cluster with a consistency level of QUORUM

In a single data center cluster with a replication factor of 3, and a read consistency level of QUORUM, 2 of the 3 replicas for the given row must respond to fulfill the read request. If the contacted replicas have different versions of the row, the replica with the most recent version will return the requested data. In the background, the third replica is checked for consistency with the first two, and if needed, a read repair is initiated for the out-of-date replicas.

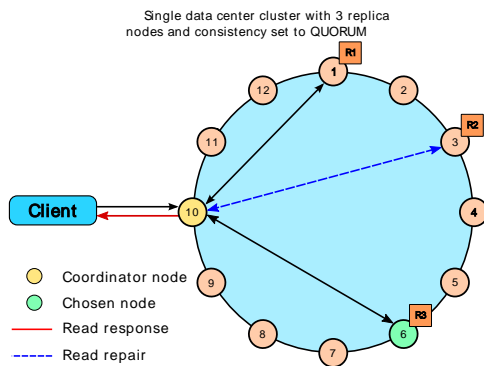

### A single data center cluster with a consistency level of ONE

In a single data center cluster with a replication factor of 3, and a read consistency level of ONE, the closest replica for the given row is contacted to fulfill the read request. In the background a read repair is potentially initiated, based on the `read_repair_chance` setting of the table, for the other replicas.

Single data center cluster with 3 replica nodes and consistency set to ONE

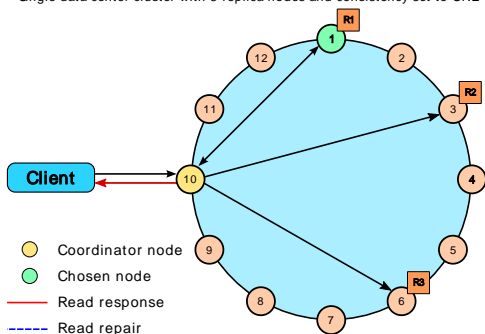

### A two data center cluster with a consistency level of QUORUM

In a two data center cluster with a replication factor of 3, and a read consistency of QUORUM, 4 replicas for the given row must respond to fulfill the read request. The 4 replicas can be from any data center. In the background, the remaining replicas are checked for consistency with the first four, and if needed, a read repair is initiated for the out-of-date replicas.

Multiple data center cluster with 3 replica nodes and consistency set to QUORUM

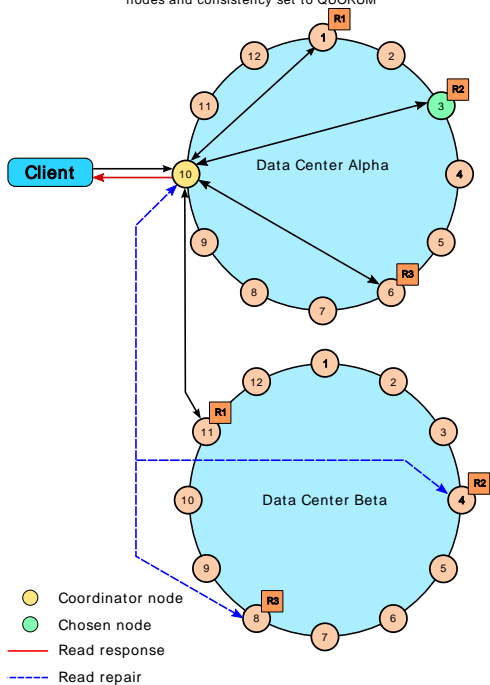

### A two data center cluster with a consistency level of LOCAL\_QUORUM

In a multiple data center cluster with a replication factor of 3, and a read consistency of LOCAL\_QUORUM, 2 replicas in the same data center as the coordinator node for the given row must respond to fulfill the read request. In the background, the remaining replicas are checked for consistency with the first 2, and if needed, a read repair is initiated for the out-of-date replicas.

## Database internals

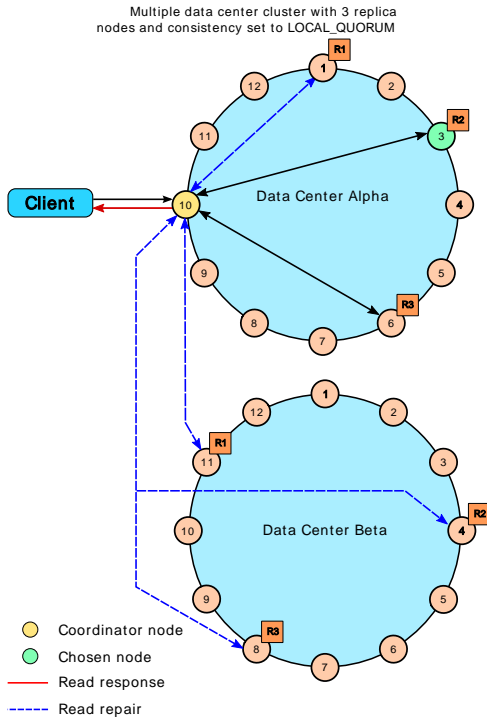

### A two data center cluster with a consistency level of ONE

In a multiple data center cluster with a replication factor of 3, and a read consistency of ONE, the closest replica for the given row, regardless of data center, is contacted to fulfill the read request. In the background a read repair is potentially initiated, based on the `read_repair_chance` setting of the table, for the other replicas.

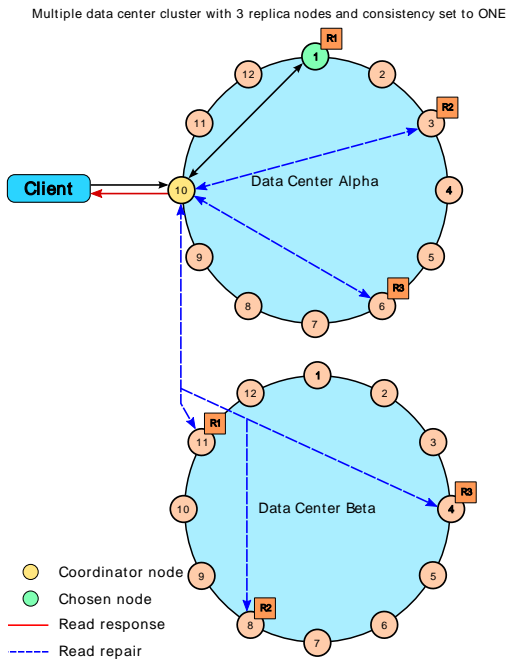

## A two data center cluster with a consistency level of LOCAL\_ONE

In a multiple data center cluster with a replication factor of 3, and a read consistency of LOCAL\_ONE, the closest replica for the given row in the same data center as the coordinator node is contacted to fulfill the read request. In the background a read repair is potentially initiated, based on the `read_repair_chance` setting of the table, for the other replicas.

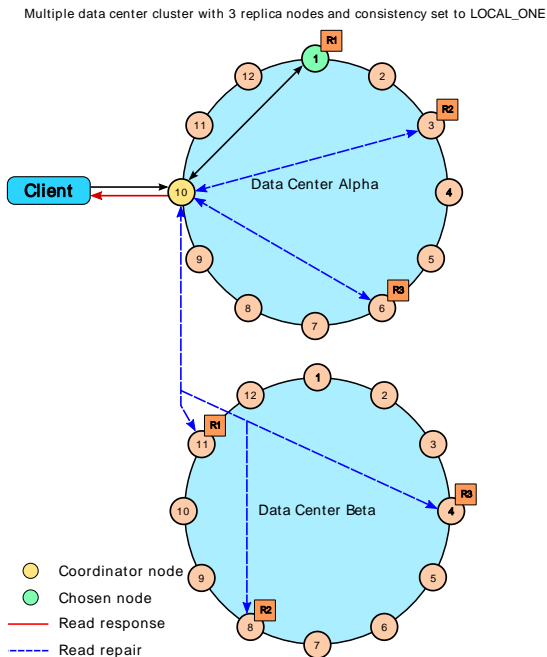

## Write requests

How write requests work.

The coordinator sends a write request to *all* replicas that own the row being written. As long as all replica nodes are up and available, they will get the write regardless of the **consistency level** specified by the client. The write consistency level determines how many replica nodes must respond with a success acknowledgment in order for the write to be considered successful. Success means that the data was written to the commit log and the memtable as described in [About writes](#).

For example, in a single data center 10 node cluster with a replication factor of 3, an incoming write will go to all 3 nodes that own the requested row. If the write consistency level specified by the client is ONE, the first node to complete the write responds back to the coordinator, which then proxies the success message back to the client. A consistency level of ONE means that it is possible that 2 of the 3 replicas could miss the write if they happened to be down at the time the request was made. If a replica misses a write, Cassandra will make the row consistent later using one of its **built-in repair mechanisms**: hinted handoff, read repair, or anti-entropy node repair.

That node forwards the write to all replicas of that row. It responds back to the client once it receives a write acknowledgment from the number of nodes specified by the consistency level.

## Database internals

Single data center cluster with 3 replica nodes and consistency set to ONE

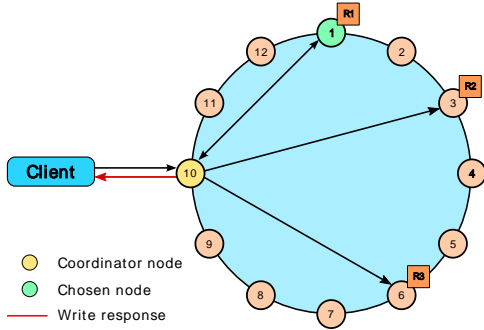

### Multiple data center write requests

How write requests work when using multiple data centers.

In multiple data center deployments, Cassandra optimizes write performance by choosing one coordinator node. The coordinator node contacted by the client application forwards the write request to each replica node in each all the data centers.

If using a **consistency level** of LOCAL\_ONE or LOCAL\_QUORUM, only the nodes in the same data center as the coordinator node must respond to the client request in order for the request to succeed. This way, geographical latency does not impact client request response times.

Multiple data center cluster with 3 replica nodes and consistency set to QUORUM

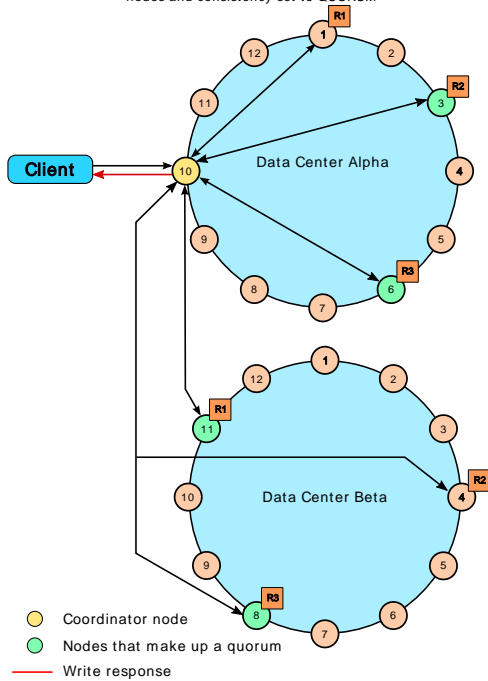

# Configuration

Configuration topics.

## The `cassandra.yaml` configuration file

The `cassandra.yaml` file is the main configuration file for Cassandra.

The `cassandra.yaml` file is the main configuration file for Cassandra.

**Important:** After changing properties in the `cassandra.yaml` file, you must restart the node for the changes to take effect. It is located in the following directories:

- Cassandra package installations: `/etc/cassandra`
- Cassandra tarball installations: `install_location/conf`
- DataStax Enterprise package installations: `/etc/dse/cassandra`
- DataStax Enterprise tarball installations: `install_location/resources/cassandra/conf`

The configuration properties are grouped into the following sections:

- **Quick start**  
The minimal properties needed for configuring a cluster.
- **Commonly used**  
Properties most frequently used when configuring Cassandra.
- **Performance tuning**  
Tuning performance and system resource utilization, including commit log, compaction, memory, disk I/O, CPU, reads, and writes.
- **Advanced**  
Properties for advanced users or properties that are less commonly used.
- **Security**  
Server and client security settings.

**Note:** Values with <sup>note</sup> indicate default values that are defined internally, missing, commented out, or implementation depends on other properties in the `cassandra.yaml` file. Additionally, some commented out values may not match the actual default value; these values are recommended when changing from the default.

### Quick start properties

The minimal properties needed for configuring a cluster.

Related information: [Initializing a multiple node cluster \(single data center\)](#) and [Initializing a multiple node cluster \(multiple data centers\)](#).

#### `cluster_name`

(Default: Test Cluster) The name of the cluster. This setting prevents nodes in one logical cluster from joining another. All nodes in a cluster must have the same value.

#### `listen_address`

(Default: localhost) The IP address or hostname that Cassandra binds to for connecting to other Cassandra nodes. Set this parameter or `listen_interface`, not both. You must change the default setting for multiple nodes to communicate:

## Configuration

- Generally set to empty. If the node is properly configured (host name, name resolution, and so on), Cassandra uses `InetAddress.getLocalHost()` to get the local address from the system.
- For a single node cluster, you can use the default setting (localhost).
- If Cassandra can't find the correct address, you must specify the IP address or host name.
- Never specify 0.0.0.0; it is always wrong.

### listen\_interface

(Default: eth0)<sup>note</sup> The interface that Cassandra binds to for connecting to other Cassandra nodes. Interfaces must correspond to a single address, IP aliasing is not supported. See [listen\\_address](#).

#### *Default directories*

If you have changed any of the default directories during installation, make sure you have root access and set these properties:

### commitlog\_directory

The directory where the commit log is stored. Default locations:

- Package installations: `/var/lib/cassandra/commitlog`
- Tarball installations: `install_location/data/commitlog`

For optimal write performance, place the commit log be on a separate disk partition, or (ideally) a separate physical device from the data file directories. Because the commit log is append only, an HDD for is acceptable for this purpose.

### data\_file\_directories

The directory location where table data (SSTables) is stored. Cassandra distributes data evenly across the location, subject to the granularity of the configured compaction strategy. Default locations:

- Package installations: `/var/lib/cassandra/data`
- Tarball installations: `install_location/data/data`

As a production best practice, use [RAID 0 and SSDs](#).

### saved\_caches\_directory

The directory location where table key and row caches are stored. Default location:

- Package installations: `/var/lib/cassandra/saved_caches`
- Tarball installations: `install_location/data/saved_caches`

## Commonly used properties

Properties most frequently used when configuring Cassandra.

Before starting a node for the first time, you should carefully evaluate your requirements.

#### *Common initialization properties*

**Note:** Be sure to set the properties in the [Quick start section](#) as well.

### commit\_failure\_policy

(Default: stop) Policy for commit disk failures:

- die  
Shut down gossip and Thrift and kill the JVM, so the node can be replaced.
- stop  
Shut down gossip and Thrift, leaving the node effectively dead, but can be inspected using JMX.
- stop\_commit  
Shut down the commit log, letting writes collect but continuing to service reads (as in pre-2.0.5 Cassandra).



- ignore

Ignore fatal errors and let the batches fail.

### disk\_failure\_policy

(Default: stop) Sets how Cassandra responds to disk failure. Recommend settings are stop or best\_effort.

- die

Shut down gossip and Thrift and kill the JVM for any file system errors or single SSTable errors, so the node can be replaced.

- stop\_paranoid

Shut down gossip and Thrift even for single SSTable errors.

- stop

Shut down gossip and Thrift, leaving the node effectively dead, but available for inspection using JMX.

- best\_effort

Stop using the failed disk and respond to requests based on the remaining available SSTables. This means you will see obsolete data at consistency level of ONE.

- ignore

Ignores fatal errors and lets the requests fail; all file system errors are logged but otherwise ignored. Cassandra acts as in versions prior to 1.2.

Related information: [Handling Disk Failures In Cassandra 1.2](#) blog and [Recovering using JBOD](#).

### endpoint\_snitch

(Default: `org.apache.cassandra.locator.SimpleSnitch`) Set to a class that implements the `IEndpointSnitch`. Cassandra uses snitches for locating nodes and routing requests.

- SimpleSnitch

Use for single-data center deployments or single-zone in public clouds. Does not recognize data center or rack information. It treats strategy order as proximity, which can improve cache locality when disabling read repair.

- GossipingPropertyFileSnitch

Recommended for production. The rack and data center for the local node are defined in the `cassandra-rackdc.properties` file and propagated to other nodes via gossip. To allow migration from the PropertyFileSnitch, it uses the `cassandra-topology.properties` file if it is present.

- PropertyFileSnitch

Determines proximity by rack and data center, which are explicitly configured in the `cassandra-topology.properties` file.

- Ec2Snitch

For EC2 deployments in a single region. Loads region and availability zone information from the EC2 API. The region is treated as the data center and the availability zone as the rack. Uses only private IPs. Subsequently it does not work across multiple regions.

- Ec2MultiRegionSnitch

Uses public IPs as the `broadcast_address` to allow cross-region connectivity. This means you must also set `seed` addresses to the public IP and open the `storage_port` or `ssl_storage_port` on the public IP firewall. For intra-region traffic, Cassandra switches to the private IP after establishing a connection.

- RackInferringSnitch:

Proximity is determined by rack and data center, which are assumed to correspond to the 3rd and 2nd octet of each node's IP address, respectively. This snitch is best used as an example for writing a custom snitch class (unless this happens to match your deployment conventions).

Related information: [Snitches](#)

## Configuration

### rpc\_address

(Default: localhost) The listen address for client connections (Thrift RPC service and native transport). Valid values are:

- unset:

Resolves the address using the hostname configuration of the node. If left unset, the hostname must resolve to the IP address of this node using `/etc/hostname`, `/etc/hosts`, or DNS.

- 0.0.0.0:

Listens on all configured interfaces, but you must set the `broadcast_rpc_address` to a value other than 0.0.0.0.

- IP address
- hostname

Related information: [Network](#)

### rpc\_interface

(Default: eth1)<sup>note</sup> The listen address for client connections. Interfaces must correspond to a single address, IP aliasing is not supported. See `rpc_address`.

### seed\_provider

The addresses of hosts deemed contact points. Cassandra nodes use the `-seeds` list to find each other and learn the topology of the ring.

- `class_name` (Default: `org.apache.cassandra.locator.SimpleSeedProvider`)

The class within Cassandra that handles the seed logic. It can be customized, but this is typically not required.

- `-seeds` (Default: `127.0.0.1`)

A comma-delimited list of IP addresses used by `gossip` for bootstrapping new nodes joining a cluster. When running multiple nodes, you must change the list from the default value. In multiple data-center clusters, the seed list should include at least one node from each data center (replication group). More than a single seed node per data center is recommended for fault tolerance. Otherwise, gossip has to communicate with another data center when bootstrapping a node. Making every node a seed node is **not** recommended because of increased maintenance and reduced gossip performance. Gossip optimization is not critical, but it is recommended to use a small seed list (approximately three nodes per data center).

Related information: [Initializing a multiple node cluster \(single data center\)](#) and [Initializing a multiple node cluster \(multiple data centers\)](#).

*Common compaction settings*

### compaction\_throughput\_mb\_per\_sec

(Default: 16) Throttles compaction to the specified total throughput across the entire system. The faster you insert data, the faster you need to compact in order to keep the SSTable count down. The recommended value is 16 to 32 times the rate of write throughput (in MB/second). Setting the value to 0 disables compaction throttling.

Related information: [Configuring compaction](#)

*Common memtable settings*

### memtable\_total\_space\_in\_mb

(Default: 1/4 of heap)<sup>note</sup> Specifies the total memory used for all memtables on a node. This replaces the per-table storage settings `memtable_operations_in_millions` and `memtable_throughput_in_mb`.

Related information: [Tuning the Java heap](#)

*Common disk settings*

### concurrent\_reads

(Default: 32)<sup>note</sup> For workloads with more data than can fit in memory, the bottleneck is reads fetching data from disk. Setting to (16 × number\_of\_drives) allows operations to queue low enough in the stack so that the OS and drives can reorder them. The default setting applies to both logical volume managed (LVM) and RAID drives.

#### concurrent\_writes

(Default: 32)<sup>note</sup> Writes in Cassandra are rarely I/O bound, so the ideal number of concurrent writes depends on the number of CPU cores in your system. The recommended value is 8 × number\_of\_cpu\_cores.

#### concurrent\_counter\_writes

(Default: 32)<sup>note</sup> Counter writes read the current values before incrementing and writing them back. The recommended value is (16 × number\_of\_drives) .

*Common automatic backup settings*

#### incremental\_backups

(Default: false) Backs up data updated since the last snapshot was taken. When enabled, Cassandra creates a hard link to each SSTable flushed or streamed locally in a `backups/` subdirectory of the keyspace data. Removing these links is the operator's responsibility.

Related information: [Enabling incremental backups](#)

#### snapshot\_before\_compaction

(Default: false) Enable or disable taking a snapshot before each compaction. This option is useful to back up data when there is a data format change. Be careful using this option because Cassandra does not clean up older snapshots automatically.

Related information: [Configuring compaction](#)

*Common fault detection setting*

#### phi\_convict\_threshold

(Default: 8)<sup>note</sup> Adjusts the sensitivity of the failure detector on an exponential scale. Generally this setting never needs adjusting.

Related information: [Failure detection and recovery](#)

### Performance tuning properties

Tuning performance and system resource utilization, including commit log, compaction, memory, disk I/O, CPU, reads, and writes.

*Commit log settings*

#### commitlog\_sync

(Default: periodic) The method that Cassandra uses to acknowledge writes in milliseconds:

- periodic: (Default: 10000 milliseconds [10 seconds])  
Used with `commitlog_sync_period_in_ms` to control how often the commit log is synchronized to disk. Periodic syncs are acknowledged immediately.
- batch: (Default: disabled)<sup>note</sup>  
Used with `commitlog_sync_batch_window_in_ms` (Default: 2 ms) to control how long Cassandra waits for other writes before performing a sync. When using this method, writes are not acknowledged until fsynced to disk.

Related information: [Durability](#)

#### commitlog\_segment\_size\_in\_mb

(Default: 32MB) Sets the size of the individual commitlog file segments. A commitlog segment may be archived, deleted, or recycled after all its data has been flushed to SSTables. This amount of data can

## Configuration

potentially include commitlog segments from every table in the system. The default size is usually suitable for most commitlog archiving, but if you want a finer granularity, 8 or 16 MB is reasonable.

Related information: [Commit log archive configuration](#)

### **commitlog\_total\_space\_in\_mb**

(Default: 32MB for 32-bit JVMs, 8192MB for 64-bit JVMs)<sup>note</sup> Total space used for commitlogs. If the used space goes above this value, Cassandra rounds up to the next nearest segment multiple and flushes memtables to disk for the oldest commitlog segments, removing those log segments. This reduces the amount of data to replay on start-up, and prevents infrequently-updated tables from indefinitely keeping commitlog segments. A small total commitlog space tends to cause more flush activity on less-active tables.

Related information: [Configuring memtable throughput](#)

*Compaction settings*

Related information: [Configuring compaction](#)

### **compaction\_preheat\_key\_cache**

(Default: true) When set to true, cached row keys are tracked during compaction, and re-cached to their new positions in the compacted SSTable. If you have extremely large key caches for tables, set the value to false; see [Global row and key caches properties](#).

### **concurrent\_compactors**

(Default: Smaller of number of disks or number of cores, with a minimum of 2 and a maximum of 8 per CPU core)<sup>note</sup> Sets the number of concurrent compaction processes allowed to run simultaneously on a node, not including validation [compactions](#) for [anti-entropy](#) repair. Simultaneous compactions help preserve read performance in a mixed read-write workload by mitigating the tendency of small SSTables to accumulate during a single long-running compaction. If your data directories are backed by SSD, increase this value to the number of cores. If compaction running too slowly or too fast, adjust [compaction\\_throughput\\_mb\\_per\\_sec](#) first.

### **in\_memory\_compaction\_limit\_in\_mb**

(Default: 64MB) Size limit for rows being compacted in memory. Larger rows spill to disk and use a slower two-pass compaction process. When this occurs, a message is logged specifying the row key. The recommended value is 5 to 10 percent of the available Java heap size.

### **preheat\_kernel\_page\_cache**

(Default: false) Enable or disable kernel page cache preheating from contents of the key cache after compaction. When enabled it preheats only first page (4KB) of each row to optimize for sequential access. It can be harmful for fat rows, see [CASSANDRA-4937](#) for more details.

### **sstable\_preemptive\_open\_interval\_in\_mb**

(Default: 50MB) When compacting, the replacement opens SSTables before they are completely written and uses in place of the prior SSTables for any range previously written. This setting helps to smoothly transfer reads between the SSTables by reducing page cache churn and keeps hot rows hot.

*Memtable settings*

### **memtable\_allocation\_type**

(Default: heap\_buffers) Specify the way Cassandra allocates and manages memtable memory. See [Off-heap memtables in Cassandra 2.1](#). Options are:

- heap\_buffers  
On heap NIO (non-blocking I/O) buffers.
- offheap\_buffers  
Off heap (direct) NIO buffers.
- offheap\_objects  
Native memory, eliminating NIO buffer heap overhead.

**memtable\_cleanup\_threshold**

(Default: 0.11  $1/(\text{memtable\_flush\_writers} + 1)$ )<sup>note</sup> Ratio of occupied non-flushing memtable size to total permitted size for triggering a flush of the largest memtable. Larger values mean larger flushes and less compaction, but also less concurrent flush activity, which can make it difficult to keep your disks saturated under heavy write load.

**file\_cache\_size\_in\_mb**

(Default: Smaller of 1/4 heap or 512) Total memory to use for SSTable-reading buffers.

**memtable\_flush\_queue\_size**

(Default: 4) The number of full memtables to allow pending flush (memtables waiting for a write thread). At a minimum, set to the maximum number of indexes created on a single table.

Related information: [Flushing data from the memtable](#)

**memtable\_flush\_writers**

(Default: Smaller of number of disks or number of cores with a minimum of 2 and a maximum of 8)<sup>note</sup> Sets the number of memtable flush writer threads. These threads are blocked by disk I/O, and each one holds a memtable in memory while blocked. If your data directories are backed by SSD, increase this setting to the number of cores.

**memtable\_heap\_space\_in\_mb**

(Default: 1/4 heap)<sup>note</sup> Total permitted memory to use for memtables. Triggers a flush based on [memtable\\_cleanup\\_threshold](#). Cassandra stops accepting writes when the limit is exceeded until a flush completes. If unset, sets to default.

**memtable\_offheap\_space\_in\_mb**

(Default: 1/4 heap)<sup>note</sup> See [memtable\\_heap\\_space\\_in\\_mb](#).

*Cache and index settings*

**column\_index\_size\_in\_kb**

(Default: 64) Granularity of the index of rows within a partition. For huge rows, decrease this setting to improve seek time. If you use key cache, be careful not to make this setting too large because key cache will be overwhelmed. If you're unsure of the size of the rows, it's best to use the default setting.

**index\_summary\_capacity\_in\_mb**

(Default: 5% of the heap size [empty])<sup>note</sup> Fixed memory pool size in MB for SSTable index summaries. If the memory usage of all index summaries exceeds this limit, any SSTables with low read rates shrink their index summaries to meet this limit. This is a best-effort process. In extreme conditions, Cassandra may need to use more than this amount of memory.

**index\_summary\_resize\_interval\_in\_minutes**

(Default: 60 minutes) How frequently index summaries should be re-sampled. This is done periodically to redistribute memory from the fixed-size pool to SSTables proportional their recent read rates. To disable, set to -1. This leaves existing index summaries at their current sampling level.

**reduce\_cache\_capacity\_to**

(Default: 0.6) Sets the size percentage to which maximum cache capacity is reduced when Java heap usage reaches the threshold defined by [reduce\\_cache\\_sizes\\_at](#).

**reduce\_cache\_sizes\_at**

(Default: 0.85) When Java heap usage (after a full concurrent mark sweep (CMS) garbage collection) exceeds this percentage, Cassandra reduces the cache capacity to the fraction of the current size as specified by [reduce\\_cache\\_capacity\\_to](#). To disable, set the value to 1.0.

*Disks settings*

**stream\_throughput\_outbound\_megabits\_per\_sec**

(Default: 200 seconds)<sup>note</sup> Throttles all outbound streaming file transfers on a node to the specified throughput. Cassandra does mostly sequential I/O when streaming data during bootstrap or repair, which can lead to saturating the network connection and degrading client (RPC) performance.

## Configuration

### `inter_dc_stream_throughput_outbound_megabits_per_sec`

(Default: unset)<sup>note</sup> Throttles all streaming file transfer between the data centers. This setting allows throttles streaming throughput between data centers in addition to throttling all network stream traffic as configured with `stream_throughput_outbound_megabits_per_sec`.

### `trickle_fsync`

(Default: false) When doing sequential writing, enabling this option tells fsync to force the operating system to flush the dirty buffers at a set interval `trickle_fsync_interval_in_kb`. Enable this parameter to avoid sudden dirty buffer flushing from impacting read latencies. Recommended to use on SSDs, but not on HDDs.

### `trickle_fsync_interval_in_kb`

(Default: 10240). Sets the size of the fsync in kilobytes.

## Advanced properties

Properties for advanced users or properties that are less commonly used.

### *Advanced initialization properties*

### `auto_bootstrap`

(Default: true) This setting has been removed from default configuration. It makes new (non-seed) nodes automatically migrate the right data to themselves. When initializing a fresh cluster *without* data, add `auto_bootstrap: false`.

Related information: [Initializing a multiple node cluster \(single data center\)](#) and [Initializing a multiple node cluster \(multiple data centers\)](#).

### `batch_size_warn_threshold_in_kb`

(Default: 5KB per batch) Log WARN on any batch size exceeding this value in kilobytes. Caution should be taken on increasing the size of this threshold as it can lead to node instability.

### `broadcast_address`

(Default: `listen_address`)<sup>note</sup> The IP address a node tells other nodes in the cluster to contact it by. It allows public and private address to be different. For example, use the `broadcast_address` parameter in topologies where not all nodes have access to other nodes by their private IP addresses.

If your Cassandra cluster is deployed across multiple Amazon EC2 regions and you use the `Ec2MultiRegionSnitch`, set the `broadcast_address` to public IP address of the node and the `listen_address` to the private IP. See [Ec2MultiRegionSnitch](#).

### `initial_token`

(Default: disabled) Used in the single-node-per-token architecture, where a node owns exactly one contiguous range in the ring space. Setting this property overrides `num_tokens`.

If you not using vnodes or have `num_tokens` set it to 1 or unspecified (`#num_tokens`), you should always specify this parameter when setting up a production cluster for the first time and when adding capacity. For more information, see this parameter in the [Cassandra 1.1 Node and Cluster Configuration](#) documentation.

This parameter can be used with `num_tokens` (vnodes) in special cases such as [Restoring from a snapshot](#).

### `num_tokens`

(Default: 256)<sup>note</sup> Defines the number of tokens randomly assigned to this node on the ring when using [virtual nodes](#) (vnodes). The more tokens, relative to other nodes, the larger the proportion of data that the node stores. Generally all nodes should have the same number of tokens assuming equal hardware capability. The recommended value is 256. If unspecified (`#num_tokens`), Cassandra uses 1 (equivalent to `#num_tokens : 1`) for legacy compatibility and uses the `initial_token` setting.

If not using vnodes, comment `#num_tokens : 256` or set `num_tokens : 1` and use `initial_token`. If you already have an existing cluster with one token per node and wish to migrate to vnodes, see [Enabling virtual nodes on an existing production cluster](#).

**Note:** If using DataStax Enterprise, the default setting of this property depends on the type of node and type of install.

### partitioner

(Default: `org.apache.cassandra.dht.Murmur3Partitioner`) Distributes rows (by partition key) across all nodes in the cluster. Any `IPartitioner` may be used, including your own as long as it is in the class path. For new clusters use the default partitioner.

Cassandra provides the following partitioners for backwards compatibility:

- `RandomPartitioner`
- `ByteOrderedPartitioner`
- `OrderPreservingPartitioner` (deprecated)

Related information: [Partitioners](#)

### storage\_port

(Default: 7000) The port for inter-node communication.

*Advanced automatic backup setting*

### auto\_snapshot

(Default: true) Enable or disable whether a snapshot is taken of the data before keyspace truncation or dropping of tables. To prevent data loss, using the default setting is strongly advised. If you set to false, you will lose data on truncation or drop.

*Key caches and global row properties*

When creating or modifying tables, you enable or disable the key cache (partition key cache) or row cache for that table by setting the caching parameter. Other row and key cache tuning and configuration options are set at the global (node) level. Cassandra uses these settings to automatically distribute memory for each table on the node based on the overall workload and specific table usage. You can also configure the save periods for these caches globally.

Related information: [Configuring caches](#)

### key\_cache\_keys\_to\_save

(Default: disabled - all keys are saved)<sup>note</sup> Number of keys from the key cache to save.

### key\_cache\_save\_period

(Default: 14400 seconds [4 hours]) Duration in seconds that keys are saved in cache. Caches are saved to [saved\\_caches\\_directory](#). Saved caches greatly improve cold-start speeds and has relatively little effect on I/O.

### key\_cache\_size\_in\_mb

(Default: empty) A global cache setting for tables. It is the maximum size of the key cache in memory. When no value is set, the cache is set to the smaller of 5% of the available heap, or 100MB. To disable set to 0.

Related information: [setcachecapacity](#).

### row\_cache\_keys\_to\_save

(Default: disabled - all keys are saved)<sup>note</sup> Number of keys from the row cache to save.

### row\_cache\_size\_in\_mb

(Default: 0- disabled) Maximum size of the row cache in memory. Row cache can save more time than [key\\_cache\\_size\\_in\\_mb](#), but is space-intensive because it contains the entire row. Use the row cache only for hot rows or static rows. If you reduce the size, you may not get you hottest keys loaded on start up.

### row\_cache\_save\_period

(Default: 0- disabled) Duration in seconds that rows are saved in cache. Caches are saved to [saved\\_caches\\_directory](#). This setting has limited use as described in [row\\_cache\\_size\\_in\\_mb](#).

### memory\_allocator



## Configuration

(Default: NativeAllocator) The off-heap memory allocator. In addition to caches, this property affects storage engine meta data. Supported values:

- NativeAllocator
- JEMallocAllocator

Experiments show that jemalloc saves some memory compared to the native allocator because it is more fragmentation resistant. To use, install jemalloc as a library and modify `cassandra-env.sh` (instructions in file).

### *Counter caches properties*

Counter cache helps to reduce counter locks' contention for hot counter cells. In case of RF = 1 a counter cache hit will cause Cassandra to skip the read before write entirely. With RF > 1 a counter cache hit will still help to reduce the duration of the lock hold, helping with hot counter cell updates, but will not allow skipping the read entirely. Only the local (clock, count) tuple of a counter cell is kept in memory, not the whole counter, so it's relatively cheap.

**Note:** Reducing the size counter cache may result in not getting the hottest keys loaded on start-up.

### **counter\_cache\_size\_in\_mb**

(Default value: empty)<sup>note</sup> When no value is specified a minimum of 2.5% of Heap or 50MB. If you perform counter deletes and rely on low `gc_grace_seconds`, you should disable the counter cache. To disable, set to 0.

### **counter\_cache\_save\_period**

(Default: 7200 seconds [2 hours]) Duration after which Cassandra should save the counter cache (keys only). Caches are saved to `saved_caches_directory`.

### **counter\_cache\_keys\_to\_save**

(Default value: disabled)<sup>note</sup> Number of keys from the counter cache to save. When disabled all keys are saved.

### *Tombstone settings*

When executing a scan, within or across a partition, tombstones must be kept in memory to allow returning them to the coordinator. The coordinator uses them to ensure other replicas know about the deleted rows. Workloads that generate numerous tombstones may cause performance problems and exhaust the server heap. See [Cassandra anti-patterns: Queues and queue-like datasets](#). Adjust these thresholds only if you understand the impact and want to scan more tombstones. Additionally, you can adjust these thresholds at runtime using the `StorageServiceMBean`.

Related information: [Cassandra anti-patterns: Queues and queue-like datasets](#)

### **tombstone\_warn\_threshold**

(Default: 1000) The maximum number of tombstones a query can scan before warning.

### **tombstone\_failure\_threshold**

(Default: 100000) The maximum number of tombstones a query can scan before aborting.

### *Network timeout settings*

### **range\_request\_timeout\_in\_ms**

(Default: 10000 milliseconds) The time that the coordinator waits for sequential or index scans to complete.

### **read\_request\_timeout\_in\_ms**

(Default: 5000 milliseconds) The time that the coordinator waits for read operations to complete.

### **counter\_write\_request\_timeout\_in\_ms**

(Default: 5000 milliseconds) The time that the coordinator waits for counter writes to complete.

### **cas\_contention\_timeout\_in\_ms**



(Default: 1000 milliseconds) The time that the coordinator continues to retry a CAS (compare and set) operation that contends with other proposals for the same row.

#### **truncate\_request\_timeout\_in\_ms**

(Default: 60000 milliseconds) The time that the coordinator waits for truncates (remove all data from a table) to complete. The long default value allows for a snapshot to be taken before removing the data. If [auto\\_snapshot](#) is disabled (not recommended), you can reduce this time.

#### **write\_request\_timeout\_in\_ms**

(Default: 2000 milliseconds) The time that the coordinator waits for write operations to complete.

Related information: [About hinted handoff writes](#)

#### **request\_timeout\_in\_ms**

(Default: 10000 milliseconds) The default time for other, miscellaneous operations.

Related information: [About hinted handoff writes](#)

#### *Inter-node settings*

#### **cross\_node\_timeout**

(Default: false) Enable or disable operation timeout information exchange between nodes (to accurately measure request timeouts). If disabled Cassandra assumes the request are forwarded to the replica instantly by the coordinator, which means that under overload conditions extra time is required for processing already-timed-out requests..

**Caution:** Before enabling this property make sure NTP (network time protocol) is installed and the times are synchronized between the nodes.

#### **internode\_send\_buff\_size\_in\_bytes**

(Default: N/A)<sup>note</sup> Sets the sending socket buffer size in bytes for inter-node calls.

When setting this parameter and [internode\\_rcv\\_buff\\_size\\_in\\_bytes](#), the buffer size is limited by `net.core.wmem_max`. When unset, buffer size is defined by `net.ipv4.tcp_wmem`. See `man tcp` and:

- `/proc/sys/net/core/wmem_max`
- `/proc/sys/net/core/rmem_max`
- `/proc/sys/net/ipv4/tcp_wmem`
- `/proc/sys/net/ipv4/tcp_wmem`

#### **internode\_rcv\_buff\_size\_in\_bytes**

(Default: N/A)<sup>note</sup> Sets the receiving socket buffer size in bytes for inter-node calls.

#### **internode\_compression**

(Default: all) Controls whether traffic between nodes is compressed. The valid values are:

- all
  - All traffic is compressed.
- dc
  - Traffic between data centers is compressed.
- none
  - No compression.

#### **inter\_dc\_tcp\_nodelay**

(Default: false) Enable or disable `tcp_nodelay` for inter-data center communication. When disabled larger, but fewer, network packets are sent. This reduces overhead from the TCP protocol itself. However, if cross data-center responses are blocked, it will increase latency.

#### **streaming\_socket\_timeout\_in\_ms**

## Configuration

(Default: 0 - never timeout streams)<sup>note</sup> Enable or disable socket timeout for streaming operations. When a timeout occurs during streaming, streaming is retried from the start of the current file. Avoid setting this value too low, as it can result in a significant amount of data re-streaming.

*Native transport (CQL Binary Protocol)*

### **start\_native\_transport**

(Default: true) Enable or disable the native transport server. Uses the same address as the `rpc_address`, but the port is different from the `rpc_port`. See `native_transport_port`.

### **native\_transport\_port**

(Default: 9042) Port on which the CQL native transport listens for clients.

### **native\_transport\_max\_threads**

(Default: 128)<sup>note</sup> The maximum number of thread handling requests. Similar to `rpc_max_threads` and differs as follows:

- Default is different (128 versus unlimited).
- No corresponding `native_transport_min_threads`.
- Idle threads are stopped after 30 seconds.

### **native\_transport\_max\_frame\_size\_in\_mb**

(Default: 256MB) The maximum size of allowed frame. Frame (requests) larger than this are rejected as invalid.

*RPC (remote procedure call) settings*

Settings for configuring and tuning client connections.

### **broadcast\_rpc\_address**

(Default: unset)<sup>note</sup> RPC address to broadcast to drivers and other Cassandra nodes. This cannot be set to 0.0.0.0. If blank, it is set to the value of the `rpc_address` or `rpc_interface`. If `rpc_address` or `rpc_interface` is set to 0.0.0.0, this property must be set.

### **rpc\_port**

(Default: 9160) Thrift port for client connections.

### **start\_rpc**

(Default: true) Starts the Thrift RPC server.

### **rpc\_keepalive**

(Default: true) Enable or disable keepalive on client connections (RPC or native).

### **rpc\_max\_threads**

(Default: unlimited)<sup>note</sup> Regardless of your choice of RPC server (`rpc_server_type`), the number of maximum requests in the RPC thread pool dictates how many concurrent requests are possible. However, if you are using the parameter `sync` in the `rpc_server_type`, it also dictates the number of clients that can be connected. For a large number of client connections, this could cause excessive memory usage for the thread stack. Connection pooling on the client side is highly recommended. Setting a maximum thread pool size acts as a safeguard against misbehaved clients. If the maximum is reached, Cassandra blocks additional connections until a client disconnects.

### **rpc\_min\_threads**

(Default: 16)<sup>note</sup> Sets the minimum thread pool size for remote procedure calls.

### **rpc\_recv\_buff\_size\_in\_bytes**

(Default: N/A)<sup>note</sup> Sets the receiving socket buffer size for remote procedure calls.

### **rpc\_send\_buff\_size\_in\_bytes**

(Default: N/A)<sup>note</sup> Sets the sending socket buffer size in bytes for remote procedure calls.

### **rpc\_server\_type**

(Default: sync) Cassandra provides three options for the RPC server. On Windows, sync is about 30% slower than hsha. On Linux, sync and hsha performance is about the same, but hsha uses less memory.

- sync: (Default One thread per Thrift connection.)

For a very large number of clients, memory is the limiting factor. On a 64-bit JVM, 180KB is the minimum stack size per thread and corresponds to your use of virtual memory. Physical memory may be limited depending on use of stack space.

- hsha:

Half synchronous, half asynchronous. All Thrift clients are handled asynchronously using a small number of threads that does not vary with the number of clients and thus scales well to many clients. The RPC requests are synchronous (one thread per active request).

**Note:** When selecting this option, you must change the default value (unlimited) of [rpc\\_max\\_threads](#).

- Your own RPC server

You must provide a fully-qualified class name of an `o.a.c.t.TServerFactory` that can create a server instance.

#### *Advanced fault detection settings*

Settings to handle poorly performing or failing nodes.

#### **dynamic\_snitch\_badness\_threshold**

(Default: 0.1) Sets the performance threshold for dynamically routing client requests away from a poorly performing node. Specifically, it controls how much worse a poorly performing node has to be before the [dynamic snitch](#) prefers other replicas over it. A value of 0.2 means Cassandra continues to prefer the static snitch values until the node response time is 20% worse than the best performing node. Until the threshold is reached, incoming requests are statically routed to the closest replica (as determined by the snitch). If the value of this parameter is greater than zero and [read\\_repair\\_chance](#) is less than 1.0, cache capacity is maximized across the nodes.

#### **dynamic\_snitch\_reset\_interval\_in\_ms**

(Default: 600000 milliseconds) Time interval to reset all node scores, which allows a bad node to recover.

#### **dynamic\_snitch\_update\_interval\_in\_ms**

(Default: 100 milliseconds) The time interval for how often the snitch calculates node scores. Because score calculation is CPU intensive, be careful when reducing this interval.

#### **hinted\_handoff\_enabled**

(Default: true) Enable or disable hinted handoff. To enable per data center, add data center list. For example: `hinted_handoff_enabled: DC1,DC2`. A hint indicates that the write needs to be replayed to an unavailable node. Where Cassandra writes the hint depends on the version:

- Prior to 1.0  
Writes to a live replica node.
- 1.0 and later  
Writes to the coordinator node.

Related information: [About hinted handoff writes](#)

#### **hinted\_handoff\_throttle\_in\_kb**

(Default: 1024) Maximum throttle per delivery thread in kilobytes per second. This rate reduces proportionally to the number of nodes in the cluster. For example, if there are two nodes in the cluster, each delivery thread will use the maximum rate. If there are three, each node will throttle to half of the maximum, since the two nodes are expected to deliver hints simultaneously.

#### **max\_hint\_window\_in\_ms**

## Configuration

(Default: 10800000 milliseconds [3 hours]) Maximum amount of time that hints are generated for an unresponsive node. After this interval, new hints are no longer generated until the node is back up and responsive. If the node goes down again, a new interval begins. This setting can prevent a sudden demand for resources when a node is brought back online and the rest of the cluster attempts to replay a large volume of hinted writes.

Related information: [Failure detection and recovery](#)

### **max\_hints\_delivery\_threads**

(Default: 2) Number of threads with which to deliver hints. In multiple data-center deployments, consider increasing this number because cross data-center handoff is generally slower.

### **batchlog\_replay\_throttle\_in\_kb**

(Default: 1024KB per second) Total maximum throttle. Throttling is reduced proportionally to the number of nodes in the cluster.

#### *Request scheduler properties*

Settings to handle incoming client requests according to a defined policy. If you need to use these properties, your nodes are overloaded and dropping requests. It is recommended that you add more nodes and not try to prioritize requests.

### **request\_scheduler**

(Default: `org.apache.cassandra.scheduler.NoScheduler`) Defines a scheduler to handle incoming client requests according to a defined policy. This scheduler is useful for throttling client requests in single clusters containing multiple keyspaces. This parameter is specifically for requests from the client and does not affect inter-node communication. Valid values are:

- `org.apache.cassandra.scheduler.NoScheduler`  
No scheduling takes place.
- `org.apache.cassandra.scheduler.RoundRobinScheduler`  
Round robin of client requests to a node with a separate queue for each `request_scheduler_id` property.
- A Java class that implements the `RequestScheduler` interface.

### **request\_scheduler\_id**

(Default: `keyspace`)<sup>note</sup> An identifier on which to perform request scheduling. Currently the only valid value is `keyspace`. See [weights](#).

### **request\_scheduler\_options**

(Default: disabled) Contains a list of properties that define configuration options for `request_scheduler`:

- `throttle_limit`  
The number of in-flight requests per client. Requests beyond this limit are queued up until running requests complete. Recommended value is  $((\text{concurrent\_reads} + \text{concurrent\_writes}) \times 2)$ .
- `default_weight`: (Default: 1)<sup>note</sup>  
How many requests are handled during each turn of the `RoundRobin`.
- `weights`: (Default: `Keyspace: 1`)  
Takes a list of keyspaces. It sets how many requests are handled during each turn of the `RoundRobin`, based on the `request_scheduler_id`.

#### *Thrift interface properties*

Legacy API for older clients. [CQL](#) is a simpler and better API for Cassandra.

### **thrift\_framed\_transport\_size\_in\_mb**

(Default: 15) Frame size (maximum field length) for Thrift. The frame is the row or part of the row that the application is inserting.

### **thrift\_max\_message\_length\_in\_mb**

(Default: 16) The maximum length of a Thrift message in megabytes, including all fields and internal Thrift overhead (1 byte of overhead for each frame). Message length is usually used in conjunction with batches. A frame length greater than or equal to 24 accommodates a batch with four inserts, each of which is 24 bytes. The required message length is greater than or equal to  $24+24+24+24+4$  (number of frames).

## Security properties

Server and client security settings.

### authenticator

(Default: `AllowAllAuthenticator`) The authentication backend. It implements `IAuthenticator` for identifying users. The available authenticators are:

- `AllowAllAuthenticator`:

Disables authentication; no checks are performed.

- `PasswordAuthenticator`

Authenticates users with user names and hashed passwords stored in the `system_auth.credentials` table. If you use the default, 1, and the node with the lone replica goes down, you will not be able to log into the cluster because the `system_auth` keyspace was not replicated.

Related information: [Internal authentication](#)

### internode\_authenticator

(Default: `enabled`)<sup>note</sup> Internode authentication backend. It implements `org.apache.cassandra.auth.AllowAllInternodeAuthenticator` to allow or disallow connections from peer nodes.

### authorizer

(Default: `AllowAllAuthorizer`) The authorization backend. It implements `IAuthenticator` to limit access and provide permissions. The available authorizers are:

- `AllowAllAuthorizer`

Disables authorization; allows any action to any user.

- `CassandraAuthorizer`

Stores permissions in `system_auth.permissions` table. If you use the default, 1, and the node with the lone replica goes down, you will not be able to log into the cluster because the `system_auth` keyspace was not replicated.

Related information: [Object permissions](#)

### permissions\_validity\_in\_ms

(Default: 2000) How long permissions in cache remain valid. Depending on the authorizer, such as `CassandraAuthorizer`, fetching permissions can be resource intensive. This setting disabled when set to 0 or when `AllowAllAuthorizer` is set.

Related information: [Object permissions](#)

### permissions\_update\_interval\_in\_ms

(Default: same value as `permissions_validity_in_ms`)<sup>note</sup> Refresh interval for permissions cache (if enabled). After this interval, cache entries become eligible for refresh. On next access, an async reload is scheduled and the old value is returned until it completes. If `permissions_validity_in_ms` is non-zero, then this property must be non-zero.

### server\_encryption\_options

Enable or disable inter-node encryption. You must also generate keys and provide the appropriate key and trust store locations and passwords. No custom encryption options are currently enabled. The available options are:

## Configuration

- `internode_encryption`: (Default: none) Enable or disable encryption of inter-node communication using the `TLS_RSA_WITH_AES_128_CBC_SHA` cipher suite for authentication, key exchange, and encryption of data transfers. Use the DHE/ECDHE ciphers if running in (Federal Information Processing Standard) FIPS 140 compliant mode. The available inter-node options are:
  - `all`  
Encrypt all inter-node communications.
  - `none`  
No encryption.
  - `dc`  
Encrypt the traffic between the data centers (server only).
  - `rack`  
Encrypt the traffic between the racks (server only).
- `keystore`: (Default: `conf/.keystore`)  
The location of a Java keystore (JKS) suitable for use with Java Secure Socket Extension (JSSE), which is the Java version of the Secure Sockets Layer (SSL), and Transport Layer Security (TLS) protocols. The keystore contains the private key used to encrypt outgoing messages.
- `keystore_password`: (Default: `cassandra`)  
Password for the keystore.
- `truststore`: (Default: `conf/.truststore`)  
Location of the truststore containing the trusted certificate for authenticating remote servers.
- `truststore_password`: (Default: `cassandra`)  
Password for the truststore.

The passwords used in these options must match the passwords used when generating the keystore and truststore. For instructions on generating these files, see [Creating a Keystore to Use with JSSE](#).

The advanced settings are:

- `protocol`: (Default: TLS)
- `algorithm`: (Default: SunX509)
- `store_type`: (Default: JKS)
- `cipher_suites`: (Default: `TLS_RSA_WITH_AES_128_CBC_SHA,TLS_RSA_WITH_AES_256_CBC_SHA`)
- `require_client_auth`: (Default: false)  
Enables or disables certificate authentication.

Related information: [Node-to-node encryption](#)

### `client_encryption_options`

Enable or disable client-to-node encryption. You must also generate keys and provide the appropriate key and trust store locations and passwords. No custom encryption options are currently enabled. The available options are:

- `enabled`: (Default: false)  
To enable, set to true.
- `keystore`: (Default: `conf/.keystore`)  
The location of a Java keystore (JKS) suitable for use with Java Secure Socket Extension (JSSE), which is the Java version of the Secure Sockets Layer (SSL), and Transport Layer Security (TLS) protocols. The keystore contains the private key used to encrypt outgoing messages.
- `keystore_password`: (Default: `cassandra`)

Password for the keystore. This must match the password used when generating the keystore and truststore.

- `require_client_auth`: (Default: false)

Enables or disables certificate authentication. (Available starting with Cassandra 1.2.3.)

- `truststore`: (Default: `conf/.truststore`)

Set if `require_client_auth` is true.

- `truststore_password`: `<truststore_password>`

Set if `require_client_auth` is true.

The advanced settings are:

- `protocol`: (Default: TLS)
- `algorithm`: (Default: SunX509)
- `store_type`: (Default: JKS)
- `cipher_suites`: (Default: TLS\_RSA\_WITH\_AES\_128\_CBC\_SHA, TLS\_RSA\_WITH\_AES\_256\_CBC\_SHA)

Related information: [Client-to-node encryption](#)

### ssl\_storage\_port

(Default: 7001) The SSL port for encrypted communication. Unused unless enabled in `encryption_options`.

## Configuring gossip settings

Using the `cassandra.yaml` file to configure gossip.

### About this task

When a node first starts up, it looks at its `cassandra.yaml` configuration file to determine the name of the Cassandra cluster it belongs to; which nodes (called *seeds*) to contact to obtain information about the other nodes in the cluster; and other parameters for determining port and range information.

The location of the `cassandra.yaml` file depends on the type of installation:

Package installations	<code>/etc/cassandra/cassandra.yaml</code>
Tarball installations	<code>install_location/resources/cassandra/conf/cassandra.yaml</code>

### Procedure

In the `cassandra.yaml` file, set the following parameters:

Property	Description
<b><code>cluster_name</code></b>	Name of the cluster that this node is joining. Must be the same for every node in the cluster.
<b><code>listen_address</code></b>	The IP address or hostname that Cassandra binds to for connecting to other Cassandra nodes.
<b>(Optional) <code>broadcast_address</code></b>	The IP address a node tells other nodes in the cluster to contact it by. It allows public and private address to be different. For example, use the <code>broadcast_address</code> parameter in topologies where not all nodes have access to other nodes

## Configuration

Property	Description
<code>seed_provider</code>	by their private IP addresses. The default is the <code>listen_address</code> .  A <code>-seeds</code> list is comma-delimited list of hosts (IP addresses) that gossip uses to learn the topology of the ring. Every node should have the same list of seeds. In multiple data-center clusters, the seed list should include at least one node from each data center (replication group). More than a single seed node per data center is recommended for fault tolerance. Otherwise, gossip has to communicate with another data center when bootstrapping a node. Making every node a seed node is <b>not</b> recommended because of increased maintenance and reduced gossip performance. Gossip optimization is not critical, but it is recommended to use a small seed list (approximately three nodes per data center).
<code>storage_port</code>	The inter-node communication port (default is 7000). Must be the same for every node in the cluster.
<code>initial_token</code>	For legacy clusters. Used in the single-node-per-token architecture, where a node owns exactly one contiguous range in the ring space.
<code>num_tokens</code>	For new clusters. Defines the number of tokens randomly assigned to this node on the ring when using <code>virtual nodes</code> (vnodes).

## Configuring the heap dump directory

Analyzing the heap dump file can help troubleshoot memory problems.

### About this task

Analyzing the heap dump file can help troubleshoot memory problems. Cassandra starts Java with the option `-XX:+HeapDumpOnOutOfMemoryError`. Using this option triggers a heap dump in the event of an out-of-memory condition. The heap dump file consists of references to objects that cause the heap to overflow. By default, Cassandra puts the file a subdirectory of the working, root directory when running as a service. If Cassandra does not have write permission to the root directory, the heap dump fails. If the root directory is too small to accommodate the heap dump, the server crashes.

For a heap dump to succeed and to prevent crashes, configure a heap dump directory that meets these requirements:

- Accessible to Cassandra for writing
- Large enough to accommodate a heap dump

The location of the `cassandra-env.sh` file depends on the type of installation:

Package installations	<code>/etc/cassandra/cassandra-env.sh</code>
Tarball installations	<code>install_location/conf/cassandra-env.sh</code>

Base the size of the directory on the value of the Java `-mx` option.



**Procedure**

Set the location of the heap dump in the `cassandra-env.sh` file.

1. Open the `cassandra-env.sh` file for editing.

```
# set jvm HeapDumpPath with CASSANDRA_HEAPDUMP_DIR
```

2. Scroll down to the comment about the heap dump path:

```
# set jvm HeapDumpPath with CASSANDRA_HEAPDUMP_DIR
```

3. On the line after the comment, set the `CASSANDRA_HEAPDUMP_DIR` to the path you want to use:

```
# set jvm HeapDumpPath with CASSANDRA_HEAPDUMP_DIR
CASSANDRA_HEAPDUMP_DIR =<path>
```

4. Save the `cassandra-env.sh` file and restart.

## Configuring virtual nodes

Topics about configuring virtual nodes.

### Enabling virtual nodes on a new cluster

Steps and recommendations for enabling virtual nodes (vnodes) on a new cluster.

**About this task**

Generally when all nodes have equal hardware capability, they should have the same number of virtual nodes (vnodes). If the hardware capabilities vary among the nodes in your cluster, assign a proportional number of vnodes to the larger machines. For example, you could designate your older machines to use 128 vnodes and your new machines (that are twice as powerful) with 256 vnodes.

The location of the `cassandra.yaml` file depends on the type of installation:

Package installations	<code>/etc/cassandra/cassandra.yaml</code>
Tarball installations	<code>install_location/resources/cassandra/conf/cassandra.yaml</code>

**Procedure**

Set the number of tokens on each node in your cluster with the `num_tokens` parameter in the `cassandra.yaml` file.

The recommended value is 256. Do not set the `initial_token` parameter.

### Enabling virtual nodes on an existing production cluster

Steps and recommendations for enabling virtual nodes (vnodes) on an existing production cluster.

**About this task**

You cannot directly convert a single-token nodes to a vnode. However, you can configure another data center configured with vnodes already enabled and let Cassandra automatic mechanisms distribute the existing data into the new nodes. This method has the least impact on performance.

**Procedure**

1. Add a new data center to the cluster.

## Configuration

2. Once the new data center with `vnodes` enabled is up, switch your clients to use the new data center.
3. Run a full repair with `nodetool repair`.

This step ensures that after you move the client to the new data center that any previous writes are added to the new data center and that nothing else, such as hints, is dropped when you remove the old data center.

4. Update your schema to no longer reference the old data center.
5. Remove the old data center from the cluster.

See [Decommissioning a data center](#).

## Using multiple network interfaces

Steps for configuring Cassandra for multiple network interfaces or when using different regions in cloud implementations.

### About this task

How to configure Cassandra for multiple network interfaces or when using different regions in cloud implementations.

You must configure settings in both the `cassandra.yaml` file and the property file (`cassandra-rackdc.properties` or `cassandra-topology.properties`) used by the snitch.

### Configuring `cassandra.yaml` for multiple networks or across regions in cloud implementations

In multiple networks or cross-region cloud scenarios, communication between data centers can only take place using an external IP address. The external IP address is defined in the `cassandra.yaml` file using the `broadcast_address` setting. Configure each node as follows:

1. In the `cassandra.yaml`, set the `listen_address` to the *private* IP address of the node, and the `broadcast_address` to the *public* address of the node.

This allows Cassandra nodes to bind to nodes in another network or region, thus enabling multiple data-center support. For intra- network or region traffic, Cassandra switches to the private IP after establishing a connection.

2. Set the addresses of the seed nodes in the `cassandra.yaml` file to that of the *public* IP. Private IP are not routable between networks. For example:

```
seeds: 50.34.16.33, 60.247.70.52
```

**Note:** Do not make all nodes seeds, see [Internode communications \(gossip\)](#).

3. Be sure that the `storage_port` or `ssl_storage_port` is open on the public IP firewall.

**Caution:** Be sure to enable encryption and authentication when using public IP's. See [Node-to-node encryption](#). Another option is to use a custom VPN to have local, inter-region/datacenter IP's.

### Configuring the snitch for multiple networks

External communication between the data centers can only happen when using the `broadcast_address` (public IP).

The `GossipingPropertyFileSnitch` is recommended for production. The `cassandra-rackdc.properties` file defines the data centers used by this snitch.

For each node in the network, specify its data center in `cassandra-rackdc.properties` file.

In the example below, there are two cassandra data centers and each data center is named for its workload. The data center naming convention in this example is based on the workload. You can use other conventions, such as DC1, DC2 or 100, 200. (Data center names are case-sensitive.)

Network A	Network B
<p>Node and data center:</p> <ul style="list-style-type: none"> <li>• <b>node0</b> dc=DC_A_cassandra rack=RAC1</li> <li>• <b>node1</b> dc=DC_A_cassandra rack=RAC1</li> <li>• <b>node2</b> dc=DC_B_cassandra rack=RAC1</li> <li>• <b>node3</b> dc=DC_B_cassandra rack=RAC1</li> <li>• <b>node4</b> dc=DC_A_analytics rack=RAC1</li> <li>• <b>node5</b> dc=DC_A_search rack=RAC1</li> </ul>	<p>Node and data center:</p> <ul style="list-style-type: none"> <li>• <b>node0</b> dc=DC_A_cassandra rack=RAC1</li> <li>• <b>node1</b> dc=DC_A_cassandra rack=RAC1</li> <li>• <b>node2</b> dc=DC_B_cassandra rack=RAC1</li> <li>• <b>node3</b> dc=DC_B_cassandra rack=RAC1</li> <li>• <b>node4</b> dc=DC_A_analytics rack=RAC1</li> <li>• <b>node5</b> dc=DC_A_search rack=RAC1</li> </ul>

### Configuring the snitch for cross-region communication in cloud implementations

**Note:** Be sure to use the appropriate **snitch** for your implementation. If your deploying on Amazon EC2, see the instructions in [Ec2MultiRegionSnitch](#).

In cloud deployments, the region name is treated as the data center name and availability zones are treated as racks within a data center. For example, if a node is in the us-east-1 region, us-east is the data center name and 1 is the rack location. (Racks are important for distributing replicas, but not for data center naming.)

In the example below, there are two cassandra data centers and each data center is named for its workload. The data center naming convention in this example is based on the workload. You can use other conventions, such as DC1, DC2 or 100, 200. (Data center names are case-sensitive.)

For each node, specify its data center in the cassandra-rackdc.properties. The dc\_suffix option defines the data centers used by the snitch. Any other lines are ignored.

Region: us-east	Region: us-west
<p>Node and data center:</p> <ul style="list-style-type: none"> <li>• <b>node0</b> dc_suffix=_1_cassandra</li> <li>• <b>node1</b> dc_suffix=_1_cassandra</li> <li>• <b>node2</b></li> </ul>	<p>Node and data center:</p> <ul style="list-style-type: none"> <li>• <b>node0</b> dc_suffix=_1_cassandra</li> <li>• <b>node1</b> dc_suffix=_1_cassandra</li> <li>• <b>node2</b></li> </ul>

## Configuration

Region: us-east	Region: us-west
<pre>dc_suffix=_2_cassandra</pre> <ul style="list-style-type: none"><li>• <b>node3</b></li></ul> <pre>dc_suffix=_2_cassandra</pre> <ul style="list-style-type: none"><li>• <b>node4</b></li></ul> <pre>dc_suffix=_1_analytics</pre> <ul style="list-style-type: none"><li>• <b>node5</b></li></ul> <pre>dc_suffix=_1_search</pre> <p>This results in four us-east data centers:</p> <pre>us-east_1_cassandra us-east_2_cassandra us-east_1_analytics us-east_1_search</pre>	<pre>dc_suffix=_2_cassandra</pre> <ul style="list-style-type: none"><li>• <b>node3</b></li></ul> <pre>dc_suffix=_2_cassandra</pre> <ul style="list-style-type: none"><li>• <b>node4</b></li></ul> <pre>dc_suffix=_1_analytics</pre> <ul style="list-style-type: none"><li>• <b>node5</b></li></ul> <pre>dc_suffix=_1_search</pre> <p>This results in four us-west data centers:</p> <pre>us-west_1_cassandra us-west_2_cassandra us-west_1_analytics us-west_1_search</pre>

The location of the `cassandra.yaml` file depends on the type of installation:

Package installations	<code>/etc/cassandra/cassandra.yaml</code>
Tarball installations	<code>install_location/resources/cassandra/conf/cassandra.yaml</code>

## Configuring logging

About Cassandra logging functionality using Simple Logging Facade for Java (SLF4J) with a logback backend.

Cassandra provides logging functionality using Simple Logging Facade for Java (SLF4J) with a `logback` backend. Logs are written to the `system.log` file in the Cassandra logging directory. You can configure logging `programmatically` or manually. Manual ways to configure logging are:

- Run the `nodetool setlogginglevel` command
- Configure the `logback-test.xml` or `logback.xml` file installed with Cassandra
- Use the `JConsole` tool to configure logging through JMX.

Logback looks for `logback-test.xml` first, and then for `logback.xml`. The `logback.xml` location for different types of installations is listed in the "[File locations](#)" section. For example, on tarball and source installations, `logback.xml` is located in the `install_location/conf` directory.

The XML configuration files look something like this:

```
<configuration scan="true">  
  <jmxConfigurator />  
  <appender name="FILE"  
    class="ch.qos.logback.core.rolling.RollingFileAppender">  
    <file>${cassandra.logdir}/system.log</file>  
    <rollingPolicy  
      class="ch.qos.logback.core.rolling.FixedWindowRollingPolicy">  
      <fileNamePattern>${cassandra.logdir}/system.log.%i.zip</  
fileNamePattern>  
      <minIndex>1</minIndex>  
      <maxIndex>20</maxIndex>  
    </rollingPolicy>
```

```

    <triggeringPolicy
class="ch.qos.logback.core.rolling.SizeBasedTriggeringPolicy">
    <maxFileSize>20MB</maxFileSize>
    </triggeringPolicy>
    <encoder>
    <pattern>%-5level [%thread] %date{ISO8601} %F:%L - %msg%n</pattern>
    <!-- old-style log format
    <pattern>%5level [%thread] %date{ISO8601} %F (line %L) %msg%n</
pattern>
    -->
    </encoder>
    </appender>

    <appender name="STDOUT" class="ch.qos.logback.core.ConsoleAppender">
    <encoder>
    <pattern>%-5level %date{HH:mm:ss,SSS} %msg%n</pattern>
    </encoder>
    </appender>

    <root level="INFO">
    <appender-ref ref="FILE" />
    <appender-ref ref="STDOUT" />
    </root>

    <logger name="com.thinkaurelius.thrift" level="ERROR"/>
</configuration>

```

The appender configurations specify where to print the log and its configuration. The first appender directs logs to a file. The second appender directs logs to the console. You can change the following logging functionality:

- Rolling policy
  - The policy for rolling logs over to an archive
  - Location and name of the log file
  - Location and name of the archive
  - Minimum and maximum file size to trigger rolling
- Format of the message
- The log level

### Log levels

The valid values for setting the log level include ALL for logging information at all levels, TRACE through ERROR, and OFF for no logging. TRACE creates the most verbose log, and ERROR, the least.

- ALL
- TRACE
- DEBUG
- INFO (Default)
- WARN
- ERROR
- OFF

**Note:** Increasing logging levels can generate heavy logging output on a moderately trafficked cluster.

You can use the `nodetool getlogginglevels` command to see the current logging configuration.

```

$ nodetool getlogginglevels
Logger Name          Log Level
ROOT                 INFO

```

com.thinkaurelius.thrift

ERROR

### Migrating to logback from log4j

If you upgrade from a previous version of Cassandra that used log4j, you can convert *log4j.properties* files to *logback.xml* using the logback [PropertiesTranslator](#) web-application.

### Using log file rotation

The default policy rolls the *system.log* file after the size exceeds 20MB. Archives are compressed in zip format. Logback names the log files *system.log.1.zip*, *system.log.2.zip*, and so on. For more information, see [logback documentation](#).

## Commit log archive configuration

Cassandra provides commitlog archiving and point-in-time recovery.

### About this task

Cassandra provides commitlog archiving and point-in-time recovery. You configure this feature in the *commitlog\_archiving.properties* configuration file, which is located in the following directories:

- Cassandra package installations: */etc/cassandra*
- Cassandra tarball installations: *install\_location/conf*
- DataStax Enterprise package installations: */etc/dse/cassandra*
- DataStax Enterprise tarball installations: *install\_location/resources/cassandra/conf*

The commands *archive\_command* and *restore\_command* expect only a single command with arguments. The parameters must be entered verbatim. STDOUT and STDIN or multiple commands cannot be executed. To workaround, you can script multiple commands and add a pointer to this file. To disable a command, leave it blank.

### Procedure

- Archive a commitlog segment:

Command	archive_command=	
Parameters	%path	Fully qualified path of the segment to archive.
	%name	Name of the commit log.
Example	archive_command=/bin/ln %path / backup/%name	

- Restore an archived commitlog:

Command	restore_command=	
Parameters	%from	Fully qualified path of the an archived commitlog segment from the <i>restore_directories</i> .
	%t	Name of live commit log directory.
Example	restore_command=cp -f %from %to	

- Set the restore directory location:

<b>Command</b>	<b>restore_directories=</b>
Format	<code>restore_directories=restore_directory_location</code>

- Restore mutations created up to and including the specified timestamp:

<b>Command</b>	<b>restore_point_in_time=</b>
Format	<code>&lt;timestamp&gt; (YYYY:MM:DD HH:MM:SS)</code>
Example	<code>restore_point_in_time=2013:12:11 17:00:00</code>

Restore stops when the first client-supplied timestamp is greater than the restore point timestamp. Because the order in which Cassandra receives mutations does not strictly follow the timestamp order, this can leave some mutations unrecovered.

## Generating tokens

If not using virtual nodes (vnodes), you must calculate tokens for your cluster.

If not using virtual nodes (vnodes), you must calculate tokens for your cluster.

The following topics in the Cassandra 1.1 documentation provide conceptual information about tokens:

- [Data Distribution in the Ring](#)
- [Replication Strategy](#)

### About calculating tokens for single or multiple data centers in Cassandra 1.2 and later

- Single data center deployments: calculate tokens by dividing the hash range by the number of nodes in the cluster.
- Multiple data center deployments: calculate the tokens for each data center so that the hash range is evenly divided for the nodes in each data center.

For more explanation, see be sure to read the conceptual information mentioned above.

The method used for calculating tokens depends on the type of partitioner:

### Calculating tokens for the Murmur3Partitioner

Use this method for generating tokens when you are **not** using virtual nodes (vnodes) and using the [Murmur3Partitioner](#) (default). This partitioner uses a maximum possible range of hash values from  $-2^{63}$  to  $+2^{63}-1$ . To calculate tokens for this partitioner:

```
python -c 'print [str(((2**64 / number_of_tokens) * i) - 2**63) for i in range(number_of_tokens)]'
```

For example, to generate tokens for 6 nodes:

```
python -c 'print [str(((2**64 / 6) * i) - 2**63) for i in range(6)]'
```

The command displays the token for each node:

```
[ '-9223372036854775808', '-6148914691236517206', '-3074457345618258604', '-2', '3074457345618258600', '6148914691236517202' ]
```

## Configuration

### Calculating tokens for the RandomPartitioner

To calculate tokens when using the [RandomPartitioner](#) in Cassandra 1.2 clusters, use the [Cassandra 1.1 Token Generating Tool](#).

## Hadoop support

Cassandra support for integrating Hadoop with Cassandra.

Cassandra support for integrating Hadoop with Cassandra includes:

- MapReduce
- Apache Pig

You can use Cassandra 2.1 with Hadoop 2.x or 1.x with some restrictions.

- [Isolate Cassandra and Hadoop](#) nodes in separate data centers.
- Before starting the data centers of Cassandra/Hadoop nodes, disable virtual nodes (vnodes).

To disable virtual nodes:

1. In the `cassandra.yaml` file, set `num_tokens` to 1.
2. Uncomment the `initial_token` property and set it to 1 or to the value of a generated token for a multi-node cluster.
3. Start the cluster for the first time.

Do not disable or enable vnodes on an existing cluster.

Setup and configuration, described in the [Apache docs](#), involves overlaying a Hadoop cluster on Cassandra nodes, configuring a separate server for the Hadoop NameNode/JobTracker, and installing a Hadoop TaskTracker and Data Node on each Cassandra node. The nodes in the Cassandra data center can draw from data in the HDFS Data Node as well as from Cassandra. The Job Tracker/Resource Manager (JT/RM) receives MapReduce input from the client application. The JT/RM sends a MapReduce job request to the Task Trackers/Node Managers (TT/NM) and optional clients, MapReduce and Pig. The data is written to Cassandra and results sent back to the client.



## MapReduce Process in a Cassandra/Hadoop Cluster

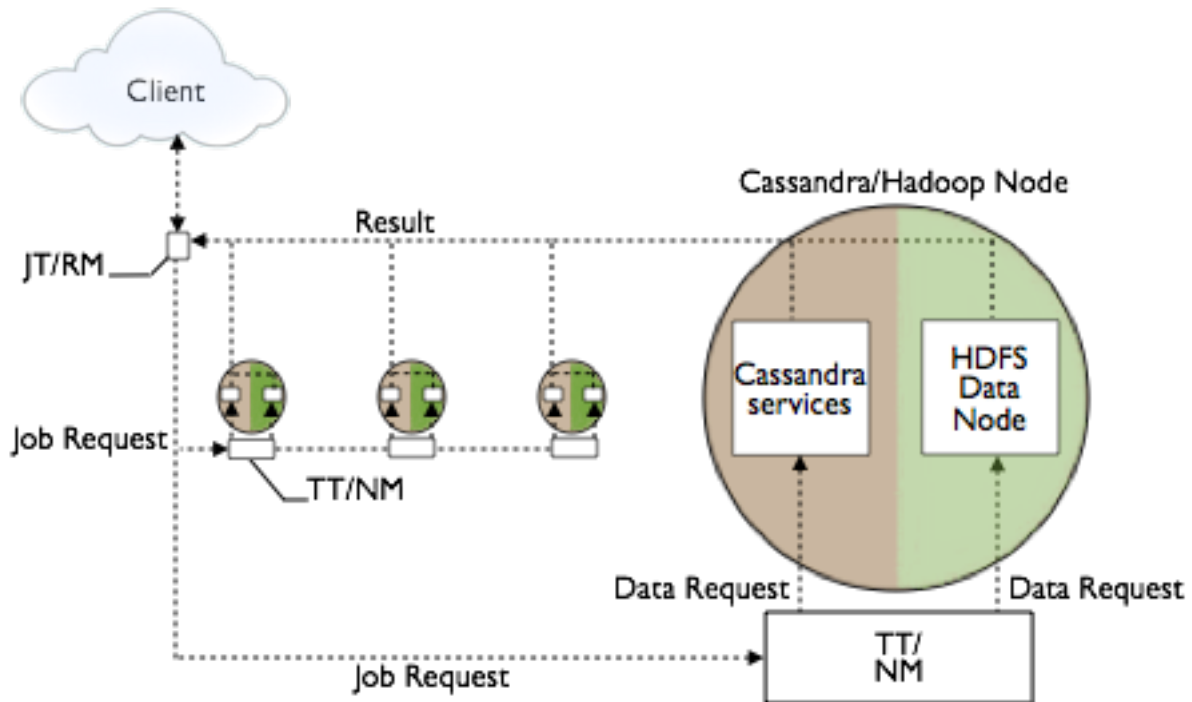

The Apache docs also cover how to get configuration and integration support.

### Input and Output Formats

Hadoop jobs can receive data from CQL tables and indexes and you can load data into Cassandra from a Hadoop job. Cassandra 2.1 supports the following formats for these tasks:

- CQL partition input format: `ColumnFamilyInputFormat` class.
- `BulkOutputFormat` class introduced in Cassandra 1.1

Cassandra 2.1.1 and later supports the `CqlOutputFormat`, which is the CQL-compatible version of the `BulkOutputFormat` class. The `CqlOutputFormat` acts as a Hadoop-specific `OutputFormat`. Reduce tasks can store keys (and corresponding bound variable values) as CQL rows (and respective columns) in a given CQL table.

Cassandra 2.1.1 supports using the `CqlOutputFormat` with Apache Pig.

### Running the wordcount example

Wordcount example JARs are located in the `examples` directory of the Cassandra source code installation. There are CQL and legacy examples in the `hadoop_cql3_word_count` and `hadoop_word_count` subdirectories, respectively. Follow instructions in the readme files.

### Isolating Hadoop and Cassandra workloads

When you create a keyspace using CQL, Cassandra creates a virtual data center for a cluster, even a one-node cluster, automatically. You assign nodes that run the same type of workload to the same data center. The separate, virtual data centers for different types of nodes segregate workloads running Hadoop from those running Cassandra. Segregating workloads ensures that only one type of workload is active per data center. Separating nodes running a sequential data load, from nodes running any other type of workload, such as Cassandra real-time OLTP queries is a best practice.

The location of the `cassandra.yaml` file depends on the type of installation:

## Configuration

Package installations	<code>/etc/cassandra/cassandra.yaml</code>
Tarball installations	<code><i>install_location</i>/resources/cassandra/ conf/cassandra.yaml</code>

# Operations

Operation topics.

## Monitoring Cassandra

Monitoring topics.

### Monitoring a Cassandra cluster

Understanding the performance characteristics of a Cassandra cluster is critical to diagnosing issues and planning capacity.

Understanding the performance characteristics of a Cassandra cluster is critical to diagnosing issues and planning capacity.

Cassandra exposes a number of statistics and management operations via Java Management Extensions (JMX). JMX is a Java technology that supplies tools for managing and monitoring Java applications and services. Any statistic or operation that a Java application has exposed as an MBean can then be monitored or manipulated using JMX.

During normal operation, Cassandra outputs information and statistics that you can monitor using JMX-compliant tools, such as:

- The Cassandra [nodetool utility](#)
- [DataStax OpsCenter](#) management console
- JConsole

Using the same tools, you can perform certain administrative commands and operations such as flushing caches or doing a [node repair](#).

### Monitoring using the nodetool utility

The [nodetool utility](#) is a command-line interface for monitoring Cassandra and performing routine database operations. Included in the Cassandra distribution, nodetool and is typically run directly from an operational Cassandra node.

The nodetool utility supports the most important JMX metrics and operations, and includes other useful commands for Cassandra administration, such as the [proxyhistogram command](#). This example shows the output from nodetool proxyhistograms after running 4,500 insert statements and 45,000 select statements on a three [ccm](#) node-cluster on a local computer.

```
$ nodetool proxyhistograms
proxy histograms
Percentile      Read Latency      Write Latency      Range Latency
                (micros)          (micros)           (micros)
50%             1502.50           375.00             446.00
75%             1714.75           420.00             498.00
95%             31210.25          507.00             800.20
98%             36365.00          577.36             948.40
99%             36365.00          740.60             1024.39
Min              616.00            230.00             311.00
Max             36365.00          55726.00           59247.00
```

For a summary of the ring and its current state of general health, use the [status command](#). For example:

```
$ nodetool status
```

## Operations

Note: Ownership information does not include topology; for complete information, specify a keyspace

Datacenter: datacenter1

=====

Status=Up/Down

|/ State=Normal/Leaving/Joining/Moving

--	Address	Load	Tokens	Owns	Host ID
	Rack				
UN	127.0.0.1	47.66 KB	1	33.3%	aaa1b7c1-6049-4a08-ad3e-3697a0e30e10 rack1
UN	127.0.0.2	47.67 KB	1	33.3%	1848c369-4306-4874-afdf-5c1e95b8732e rack1
UN	127.0.0.3	47.67 KB	1	33.3%	49578bf1-728f-438d-b1c1-d8dd644b6f7f rack1

The nodetool utility provides commands for viewing detailed metrics for tables, server metrics, and compaction statistics:

- `nodetool cfstats` displays statistics for each table and keyspace.
- `nodetool cfhistograms` provides statistics about a table, including read/write latency, row size, column count, and number of SSTables.
- `nodetool netstats` provides statistics about network operations and connections.
- `nodetool tpstats` provides statistics about the number of active, pending, and completed tasks for each stage of Cassandra operations by thread pool.

## DataStax OpsCenter

DataStax OpsCenter is a graphical user interface for monitoring and administering all nodes in a Cassandra cluster from one centralized console. DataStax OpsCenter is bundled with DataStax support offerings. You can register for a free version for development or non-production use.

OpsCenter provides a graphical representation of performance trends in a summary view that is hard to obtain with other monitoring tools. The GUI provides views for different time periods as well as the capability to drill down on single data points. Both real-time and historical performance data for a Cassandra or DataStax Enterprise cluster are available in OpsCenter. OpsCenter metrics are captured and stored within Cassandra.

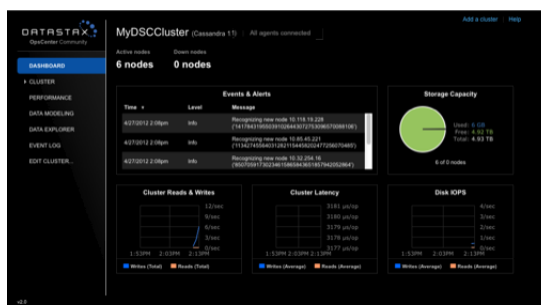

Within OpsCenter you can customize the performance metrics viewed to meet your monitoring needs. Administrators can also perform routine node administration tasks from OpsCenter. Metrics within OpsCenter are divided into three general categories: table metrics, cluster metrics, and OS metrics. For many of the available metrics, you can view aggregated cluster-wide information or view information on a per-node basis.

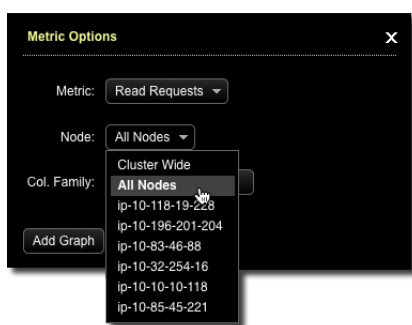

## Monitoring using JConsole

JConsole is a JMX-compliant tool for monitoring Java applications such as Cassandra. It is included with Sun JDK 5.0 and higher. JConsole consumes the JMX metrics and operations exposed by Cassandra and displays them in a well-organized GUI. For each node monitored, JConsole provides these six separate tab views:

- Overview
  - Displays overview information about the Java VM and monitored values.
- Memory
  - Displays information about memory use.
- Threads
  - Displays information about thread use.
- Classes
  - Displays information about class loading.
- VM Summary
  - Displays information about the Java Virtual Machine (VM).
- Mbeans
  - Displays information about MBeans.

The Overview and Memory tabs contain information that is very useful for Cassandra developers. The Memory tab allows you to compare heap and non-heap memory usage, and provides a control to immediately perform Java garbage collection.

For specific Cassandra metrics and operations, the most important area of JConsole is the MBeans tab. This tab lists the following Cassandra MBeans:

- org.apache.cassandra.db
  - Includes caching, table metrics, and compaction.
- org.apache.cassandra.internal
  - Internal server operations such as gossip and hinted handoff.
- org.apache.cassandra.net
  - Inter-node communication including FailureDetector, MessagingService and StreamingService.
- org.apache.cassandra.request
  - Tasks related to read, write, and replication operations.

When you select an MBean in the tree, its MBeanInfo and MBean Descriptor are displayed on the right, and any attributes, operations or notifications appear in the tree below it. For example, selecting and expanding the org.apache.cassandra.db MBean to view available actions for a table results in a display like the following:

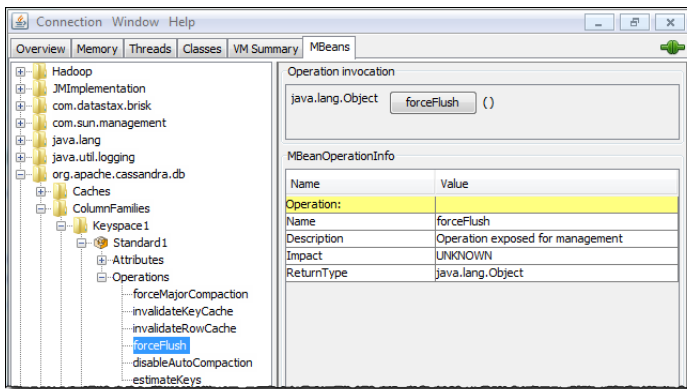

If you choose to monitor Cassandra using JConsole, keep in mind that JConsole consumes a significant amount of system resources. For this reason, DataStax recommends running JConsole on a remote machine rather than on the same host as a Cassandra node.

The JConsole CompactionManagerMBean exposes **compaction metrics** that can indicate when you need to add capacity to your cluster.

**Compaction metrics**

Monitoring compaction performance is an important aspect of knowing when to add capacity to your cluster.

Monitoring compaction performance is an important aspect of knowing when to add capacity to your cluster. The following attributes are exposed through CompactionManagerMBean:

**Table 8: Compaction Metrics**

Attribute	Description
CompletedTasks	Number of completed compactions since the last start of this Cassandra instance
PendingTasks	Number of estimated tasks remaining to perform
ColumnFamilyInProgress	The table currently being compacted. This attribute is null if no compactions are in progress.
BytesTotalInProgress	Total number of data bytes (index and filter are not included) being compacted. This attribute is null if no compactions are in progress.
BytesCompacted	The progress of the current compaction. This attribute is null if no compactions are in progress.

**Thread pool and read/write latency statistics**

Increases in pending tasks on thread pool statistics can indicate when to add additional capacity.

Cassandra maintains distinct thread pools for different stages of execution. Each of the thread pools provide statistics on the number of tasks that are active, pending, and completed. Trends on these pools for increases in the pending tasks column indicate when to add additional capacity. After a baseline is established, configure alarms for any increases above normal in the pending tasks column. Use **nodetool tpstats** on the command line to view the thread pool details shown in the following table.

**Table 9: Compaction Metrics**

Thread Pool	Description
AE_SERVICE_STAGE	Shows anti-entropy tasks.
CONSISTENCY-MANAGER	Handles the background consistency checks if they were triggered from the client's consistency level.
FLUSH-SORTER-POOL	Sorts flushes that have been submitted.
FLUSH-WRITER-POOL	Writes the sorted flushes.
GOSSIP_STAGE	Activity of the Gossip protocol on the ring.
LB-OPERATIONS	The number of load balancing operations.
LB-TARGET	Used by nodes leaving the ring.
MEMTABLE-POST-FLUSHER	Memtable flushes that are waiting to be written to the commit log.
MESSAGE-STREAMING-POOL	Streaming operations. Usually triggered by bootstrapping or decommissioning nodes.
MIGRATION_STAGE	Tasks resulting from the call of system_* methods in the API that have modified the schema.
MISC_STAGE	
MUTATION_STAGE	API calls that are modifying data.
READ_STAGE	API calls that have read data.
RESPONSE_STAGE	Response tasks from other nodes to message streaming from this node.
STREAM_STAGE	Stream tasks from this node.

**Read/Write latency metrics**

Cassandra tracks latency (averages and totals) of read, write, and slicing operations at the server level through StorageProxyMBean.

**Table statistics**

Compaction metrics provide a number of statistics that are important for monitoring performance trends.

For individual tables, ColumnFamilyStoreMBean provides the same general latency attributes as StorageProxyMBean. Unlike StorageProxyMBean, ColumnFamilyStoreMBean has a number of other statistics that are important to monitor for performance trends. The most important of these are:

**Table 10: Compaction Metrics**

Attribute	Description
MemtableDataSize	The total size consumed by this table's data (not including metadata).
MemtableColumnsCount	Returns the total number of columns present in the <b>memtable</b> (across all keys).
MemtableSwitchCount	How many times the memtable has been flushed out.
RecentReadLatencyMicros	The average read latency since the last call to this bean.
RecentWriterLatencyMicros	The average write latency since the last call to this bean.
LiveSSTableCount	The number of live SSTables for this table.

## Operations

The recent read latency and write latency counters are important in making sure operations are happening in a consistent manner. If these counters start to increase after a period of staying flat, you probably need to add capacity to the cluster.

You can set a threshold and monitor `LiveSSTableCount` to ensure that the number of `SSTables` for a given table does not become too great.

## Tuning Bloom filters

Cassandra uses Bloom filters to determine whether an SSTable has data for a particular row.

Cassandra uses Bloom filters to determine whether an SSTable has data for a particular row. Bloom filters are unused for range scans, but are used for index scans. Bloom filters are probabilistic sets that allow you to trade memory for accuracy. This means that higher Bloom filter attribute settings `bloom_filter_fp_chance` use less memory, but will result in more disk I/O if the SSTables are highly fragmented. Bloom filter settings range from 0 to 1.0 (disabled). The default value of `bloom_filter_fp_chance` depends on the `compaction strategy`. The `LeveledCompactionStrategy` uses a higher default value (0.1) than the `SizeTieredCompactionStrategy` or `DateTieredCompactionStrategy`, which have a default of 0.01. Memory savings are nonlinear; going from 0.01 to 0.1 saves about one third of the memory. SSTables using LCS contain a relatively smaller ranges of keys than those using STCS, which facilitates efficient exclusion of the SSTables even without a bloom filter; however, adding a small bloom filter helps when there are many levels in LCS.

The settings you choose depend the type of workload. For example, to run an analytics application that heavily scans a particular table, you would want to inhibit the Bloom filter on the table by setting it high.

To view the observed Bloom filters false positive rate and the number of SSTables consulted per read use `cfstats` in the `nodetool` utility.

Bloom filters are stored off-heap so you don't need include it when determining the `-Xmx` settings (the maximum memory size that the heap can reach for the JVM).

To change the `bloom filter property` on a table, use CQL. For example:

```
ALTER TABLE addamsFamily WITH bloom_filter_fp_chance = 0.1;
```

After updating the value of `bloom_filter_fp_chance` on a table, Bloom filters need to be regenerated in one of these ways:

- `Initiate compaction`
- `Upgrade SSTables`

You do not have to restart Cassandra after regenerating SSTables.

## Data caching

Data caching topics.

### Configuring data caches

Cassandra includes integrated caching and distributes cache data around the cluster. The integrated architecture facilitates troubleshooting and the cold start problem.

Cassandra includes integrated caching and distributes cache data around the cluster. When a node goes down, the client can read from another cached replica of the data. The integrated architecture also facilitates troubleshooting because there is no separate caching tier, and cached data matches what's in the database exactly. The integrated cache solves the cold start problem by saving the cache to disk periodically. Cassandra reads contents back into the cache and distributes the data when it restarts. The cluster does not start with a cold cache.



In Cassandra 2.1, the saved key cache files include the ID of the table in the file name. A saved key cache file name for the users table in the mykeyspace keyspace in a Cassandra 2.1 looks something like this: `mykeyspace-users.users_name_idx-19bd7f80352c11e4aa6a57448213f97f-KeyCache-b.db2046071785672832311.tmp`

You can configure partial or full caching of each partition by setting the `rows_per_partition` table option. Previously, the caching mechanism put the entire partition in memory. If the partition was larger than the cache size, Cassandra never read the data from the cache. Now, you can specify the number of rows to cache per partition to increase cache hits. You configure the cache using the [CQL caching property](#).

### About the partition key cache

The partition key cache is a cache of the [partition index](#) for a Cassandra table. Using the key cache instead of relying on the OS page cache decreases seek times. However, enabling just the key cache results in disk (or OS page cache) activity to actually read the requested data rows.

### About the row cache

You can configure the number of rows to cache in a partition. To cache rows, if the row key is not already in the cache, Cassandra reads the first portion of the partition, and puts the data in the cache. If the newly cached data does not include all cells configured by user, Cassandra performs another read.

Typically, you enable either the partition key or row cache for a table, except archive tables, which are infrequently read. Disable caching entirely for archive tables.

### Enabling and configuring caching

Using CQL to enable or disable caching.

### About this task

Use CQL to enable or disable caching by configuring the caching [table property](#). Set parameters in the `cassandra.yaml` file to configure global caching properties:

- [Partition key cache size](#)
- [Row cache size](#)
- How often Cassandra [saves partition key caches](#) to disk
- How often Cassandra [saves row caches](#) to disk

Set the caching property using [CREATE TABLE](#) or [ALTER TABLE](#). For example, configuring the `row_cache_size_in_mb` determines how much space in memory Cassandra allocates to store rows from the most frequently read partitions of the table.

The location of the `cassandra.yaml` file depends on the type of installation:

Package installations	<code>/etc/cassandra/cassandra.yaml</code>
Tarball installations	<code>install_location/resources/cassandra/conf/cassandra.yaml</code>

### Procedure

Set the table caching property that configures the partition key cache and the row cache.

```
CREATE TABLE users (
  userid text PRIMARY KEY,
  first_name text,
  last_name text,
)
WITH caching = { 'keys' : 'NONE', 'rows_per_partition' : '120' };
```

## Operations

### How caching works

Brief overview of how caching works.

When both row cache and partition key cache are configured, the row cache returns results whenever possible. In the event of a row cache miss, the partition key cache might still provide a hit that makes the disk seek much more efficient. This diagram depicts two read operations on a table with both caches already populated.

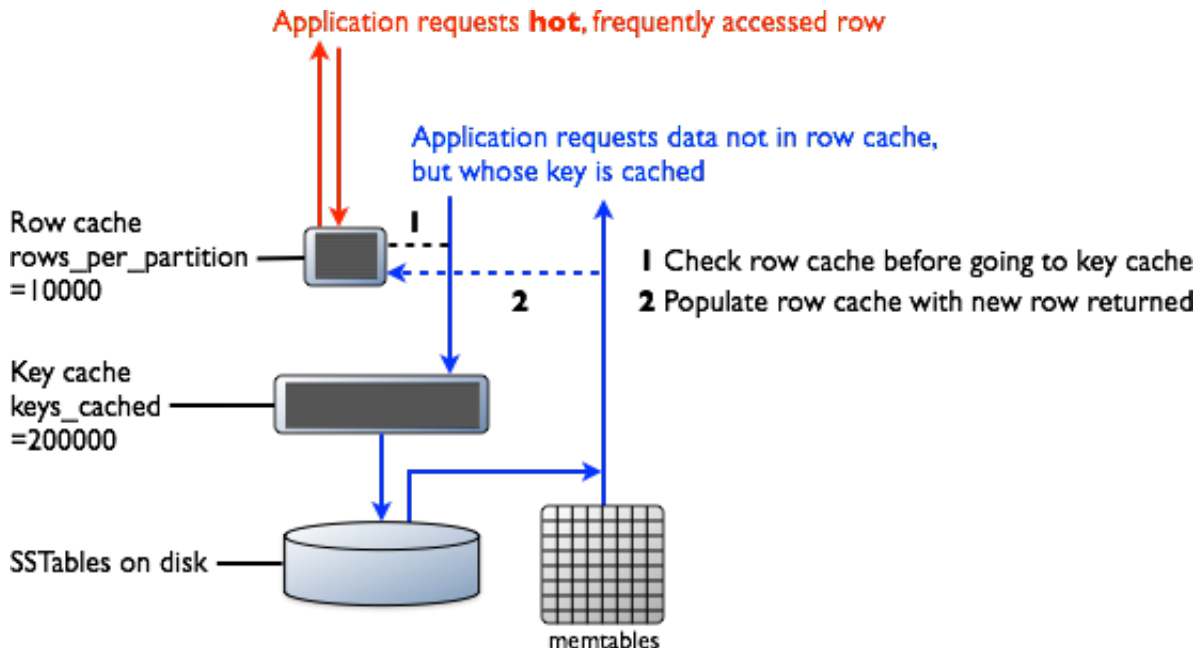

One read operation hits the row cache, returning the requested row without a disk seek. The other read operation requests a row that is not present in the row cache but is present in the partition key cache. After accessing the row in the **SSTable**, the system returns the data and populates the row cache with this read operation.

### Tips for efficient cache use

Various tips for efficient cache use.

"[Tuning the row cache in Cassandra 2.1](#)" describes best practices of using the built-in caching mechanisms and designing an effective data model. Some tips for efficient cache use are:

- Store lower-demand data or data with extremely long partitions in a table with minimal or no caching.
- Deploy a large number of Cassandra nodes under a relatively light load per node.
- Logically separate heavily-read data into discrete tables.

When you query a table, **turn on tracing** to check that the table actually gets data from the cache rather than from disk. The first time you read data from a partition, the trace shows this line below the query because the cache has not been populated yet:

```
Row cache miss [ReadStage:41]
```

In subsequent queries for the same partition, look for a line in the trace that looks something like this:

```
Row cache hit [ReadStage:55]
```

This output means the data was found in the cache and no disk read occurred. Updates invalidate the cache. If you query rows in the cache plus uncached rows, request more rows than the global limit allows,

or the query does not grab the beginning of the partition, the trace might include a line that looks something like this:

```
Ignoring row cache as cached value could not satisfy query [ReadStage:89]
```

This output indicates that an insufficient cache caused a disk read. Requesting rows not at the beginning of the partition is a likely cause. Try removing constraints that might cause the query to skip the beginning of the partition, or **place a limit** on the query to prevent results from overflowing the cache. To ensure that the query hits the cache, try increasing the cache size limit, or restructure the table to position frequently accessed rows at the head of the partition.

## Monitoring and adjusting caching

Use `nodetool` to make changes to cache options and then monitor the effects of each change.

Make changes to cache options in small, incremental adjustments, then monitor the effects of each change using [DataStax Opscenter](#) or the `nodetool` utility. The output of the `nodetool info` command shows the following row cache and key cache metrics, which are configured in the `cassandra.yaml` file:

- Cache size in bytes
- Capacity in bytes
- Number of hits
- Number of requests
- Recent hit rate
- Duration in seconds after which Cassandra saves the key cache.

For example, on start-up, the information from `nodetool info` might look something like this:

```
ID : 387d15ba-7103-491b-9327-1a691dbb504a
Gossip active : true
Thrift active : true
Native Transport active: true
Load : 65.87 KB
Generation No : 1400189757
Uptime (seconds) : 148760
Heap Memory (MB) : 392.82 / 1996.81
Data Center : datacenter1
Rack : rack1
Exceptions : 0
Key Cache : entries 10, size 728 (bytes), capacity 103809024 (bytes),
  93 hits, 102 requests, 0.912 recent hit rate, 14400 save period in seconds
Row Cache : entries 0, size 0 (bytes), capacity 0 (bytes), 0 hits, 0
  requests, NaN recent hit rate, 0 save period in seconds
Counter Cache : entries 0, size 0 (bytes), capacity 51380224 (bytes), 0
  hits, 0 requests, NaN recent hit rate, 7200 save period in seconds
Token : -9223372036854775808
```

In the event of high memory consumption, consider tuning data caches.

The location of the `cassandra.yaml` file depends on the type of installation:

Package installations	<code>/etc/cassandra/cassandra.yaml</code>
Tarball installations	<code>install_location/resources/cassandra/conf/cassandra.yaml</code>

## Configuring memtable throughput

Configuring memtable throughput to improve write performance.

Configuring memtable throughput can improve write performance. Cassandra flushes memtables to disk, creating SSTables when the **commit log space threshold** has been exceeded. Configure the commit log space threshold per node in the `cassandra.yaml`. How you tune memtable thresholds depends on your data and write load. Increase memtable throughput under either of these conditions:

- The write load includes a high volume of updates on a smaller set of data.
- A steady stream of continuous writes occurs. This action leads to more efficient compaction.

Allocating memory for memtables reduces the memory available for caching and other internal Cassandra structures, so tune carefully and in small increments.

The location of the `cassandra.yaml` file depends on the type of installation:

Package installations	<code>/etc/cassandra/cassandra.yaml</code>
Tarball installations	<code>install_location/resources/cassandra/conf/cassandra.yaml</code>

## Configuring compaction

Steps for configuring compaction. The compaction process merges keys, combines columns, evicts tombstones, consolidates SSTables, and creates a new index in the merged SSTable.

### About this task

As discussed in the **Compaction** topic, the compaction process merges keys, combines columns, evicts tombstones, consolidates SSTables, and creates a new index in the merged SSTable.

In the `cassandra.yaml` file, you configure these global compaction parameters:

- `snapshot_before_compaction`
- `in_memory_compaction_limit_in_mb`
- `compaction_preheat_key_cache`
- `concurrent_compactors`
- `compaction_throughput_mb_per_sec`

The `compaction_throughput_mb_per_sec` parameter is designed for use with large **partitions** because compaction is throttled to the specified total throughput across the entire system.

Cassandra provides a start-up option for **testing compaction strategies** without affecting the production workload.

Using CQL, you configure a compaction strategy:

- `SizeTieredCompactionStrategy` (STCS): The default compaction strategy. This strategy triggers a minor compaction when there are a number of similar sized SSTables on disk as configured by the table subproperty, `min_threshold`. A minor compaction does not involve all the tables in a keyspace. Also see **STCS compaction subproperties**.
- `DateTieredCompactionStrategy` (DTCS): Available in Cassandra 2.0.11 and 2.1.1 and later. This strategy is particularly useful for **time series data**. `DateTieredCompactionStrategy` stores data written within a certain period of time in the same SSTable. For example, Cassandra can store your last hour of data in one SSTable *time window*, and the next 4 hours of data in another time window, and so on. Compactions are triggered when the `min_threshold` (4 by default) for SSTables in those windows is reached. The most common queries for time series workloads retrieve the last hour/day/month of data. Cassandra can limit SSTables returned to those having the relevant data. Also, Cassandra can

store data that has been set to expire using TTL in an SSTable with other data scheduled to expire at approximately the same time. Cassandra can then drop the SSTable without doing any compaction. Also see [DTCS compaction subproperties](#) and [DateTieredCompactionStrategy: Compaction for Time Series Data](#).

**Note:** When using DTCS disabling [read repair](#) is recommended. Use [full repair](#) as necessary.

- `LeveledCompactionStrategy` (LCS): The leveled compaction strategy creates SSTables of a fixed, relatively small size (160 MB by default) that are grouped into levels. Within each level, SSTables are guaranteed to be non-overlapping. Each level (L0, L1, L2 and so on) is 10 times as large as the previous. Disk I/O is more uniform and predictable on higher than on lower levels as SSTables are continuously being compacted into progressively larger levels. At each level, row keys are merged into non-overlapping SSTables. This can improve performance for reads, because Cassandra can determine which SSTables in each level to check for the existence of row key data. This compaction strategy is modeled after [Google's leveledb](#) implementation. Also see [LCS compaction subproperties](#).

To configure the compaction strategy property and [CQL compaction subproperties](#), such as the maximum number of SSTables to compact and minimum SSTable size, use [CREATE TABLE](#) or [ALTER TABLE](#).

The location of the `cassandra.yaml` file depends on the type of installation:

Package installations	<code>/etc/cassandra/cassandra.yaml</code>
Tarball installations	<code>install_location/resources/cassandra/conf/cassandra.yaml</code>

## Procedure

1. Update a table to set the compaction strategy using the `ALTER TABLE` statement.

```
ALTER TABLE users WITH
  compaction = { 'class' : 'LeveledCompactionStrategy' }
```

2. Change the [compaction strategy property](#) to `SizeTieredCompactionStrategy` and specify the minimum number of SSTables to trigger a compaction using the CQL `min_threshold` attribute.

```
ALTER TABLE users
  WITH compaction =
    { 'class' : 'SizeTieredCompactionStrategy', 'min_threshold' : 6 }
```

## Results

You can monitor the results of your configuration using compaction metrics, see [Compaction metrics](#).

## Compression

Compression maximizes the storage capacity of Cassandra nodes by reducing the volume of data on disk and disk I/O, particularly for read-dominated workloads.

Compression maximizes the storage capacity of Cassandra nodes by reducing the volume of data on disk and disk I/O, particularly for read-dominated workloads. Cassandra quickly finds the location of rows in the SSTable index and decompresses the relevant row chunks.

Write performance is not negatively impacted by compression in Cassandra as it is in traditional databases. In traditional relational databases, writes require overwrites to existing data files on disk. The database has to locate the relevant pages on disk, decompress them, overwrite the relevant data, and finally recompress. In a relational database, compression is an expensive operation in terms of CPU cycles and disk I/O. Because Cassandra SSTable data files are immutable (they are not written to again after they have been flushed to disk), there is no recompression cycle necessary in order to process writes.

## Operations

SSTables are compressed only once when they are written to disk. Writes on compressed tables can show up to a 10 percent performance improvement.

### When to compress data

Compression is best suited for tables that have many rows and each row has the same columns, or at least as many columns, as other rows.

Compression is best suited for tables that have many rows and each row has the same columns, or at least as many columns, as other rows. For example, a table containing user data such as username, email, and state, is a good candidate for compression. The greater the similarity of the data across rows, the greater the compression ratio and gain in read performance.

A table that has rows of different sets of columns is not well-suited for compression.

Don't confuse table compression with **compact storage** of columns, which is used for backward compatibility of old applications with CQL.

Depending on the data characteristics of the table, compressing its data can result in:

- 2x-4x reduction in data size
- 25-35% performance improvement on reads
- 5-10% performance improvement on writes

After configuring compression on an existing table, subsequently created SSTables are compressed. Existing SSTables on disk are not compressed immediately. Cassandra compresses existing SSTables when the normal Cassandra compaction process occurs. Force existing SSTables to be rewritten and compressed by using **nodetool upgradesstables** (Cassandra 1.0.4 or later) or **nodetool scrub**.

### Configuring compression

Steps for configuring compression.

#### About this task

You configure a table property and subproperties to manage compression. The **CQL table properties documentation** describes the types of compression options that are available. Compression is enabled by default.

#### Procedure

1. Disable compression, using CQL to set the compression parameters to an empty string.

```
CREATE TABLE DogTypes (  
    block_id uuid,  
    species text,  
    alias text,  
    population varint,  
    PRIMARY KEY (block_id)  
)  
WITH compression = { 'sstable_compression' : '' };
```

2. Enable compression on an existing table, using ALTER TABLE to set the compression algorithm `sstable_compression` to LZ4Compressor (Cassandra 1.2.2 and later), SnappyCompressor, or DeflateCompressor.

```
CREATE TABLE DogTypes (  
    block_id uuid,  
    species text,  
    alias text,  
    population varint,  
    PRIMARY KEY (block_id)  
)
```

```
        WITH compression = { 'sstable_compression' :
'LZ4Compressor' };
```

3. Change compression on an existing table, using ALTER TABLE and setting the compression algorithm sstable\_compression to DeflateCompressor.

```
ALTER TABLE CatTypes
  WITH compression = { 'sstable_compression' : 'DeflateCompressor',
'chunk_length_kb' : 64 }
```

You tune data compression on a per-table basis using CQL to alter a table.

## Testing compaction and compression

Enabling write survey mode.

### About this task

Write survey mode is a Cassandra startup option for testing new compaction and compression strategies. In write survey mode, you can test out new compaction and compression strategies on that node and benchmark the write performance differences, without affecting the production cluster.

Write survey mode adds a node to a database cluster. The node accepts all write traffic as if it were part of the normal Cassandra cluster, but the node does not officially join the ring.

Also use write survey mode to try out a new Cassandra version. The nodes you add in write survey mode to a cluster must be of the same major release version as other nodes in the cluster. The write survey mode relies on the streaming subsystem that transfers data between nodes in bulk and differs from one major release to another.

If you want to see how read performance is affected by modifications, stop the node, bring it up as a standalone machine, and then benchmark read operations on the node.

### Procedure

Enable write survey mode by starting a Cassandra node using the write\_survey option.

```
$ bin/cassandra - Dcassandra.write_survey=true
```

This example shows how to start a tarball installation of Cassandra.

## Tuning Java resources

Consider tuning Java resources in the event of a performance degradation or high memory consumption.

Consider tuning Java resources in the event of a performance degradation or high memory consumption.

There are two files that control environment settings for Cassandra:

- conf/cassandra-env.sh

Java Virtual Machine (JVM) configuration settings

- bin/cassandra-in.sh

Sets up Cassandra environment variables such as CLASSPATH and JAVA\_HOME.

### Heap sizing options

If you decide to change the Java heap sizing, both MAX\_HEAP\_SIZE and HEAP\_NEWSIZE should be set together in conf/cassandra-env.sh.



## Operations

- MAX\_HEAP\_SIZE

Sets the maximum heap size for the JVM. The same value is also used for the minimum heap size. This allows the heap to be locked in memory at process start to keep it from being swapped out by the OS.

- HEAP\_NEWSIZE

The size of the young generation. The larger this is, the longer GC pause times will be. The shorter it is, the more expensive GC will be (usually). A good guideline is 100 MB per CPU core.

### Tuning the Java heap

Because Cassandra is a database, it spends significant time interacting with the operating system's I/O infrastructure through the JVM, so a well-tuned Java heap size is important. Cassandra's default configuration opens the JVM with a heap size that is based on the total amount of system memory:

System Memory	Heap Size
Less than 2GB	1/2 of system memory
2GB to 4GB	1GB
Greater than 4GB	1/4 system memory, but not more than 8GB

Many users new to Cassandra are tempted to turn up Java heap size too high, which consumes the majority of the underlying system's RAM. In most cases, increasing the Java heap size is actually detrimental for these reasons:

- In most cases, the capability of Java to gracefully handle garbage collection above 8GB quickly diminishes.
- Modern operating systems maintain the OS page cache for frequently accessed data and are very good at keeping this data in memory, but can be prevented from doing its job by an elevated Java heap size.

If you have more than 2GB of system memory, which is typical, keep the size of the Java heap relatively small to allow more memory for the page cache.

Some Solr users have reported that increasing the stack size improves performance under Tomcat. To increase the stack size, uncomment and modify the default setting in the `cassandra-env.sh` file. Also, decreasing the memtable space to make room for Solr caches might improve performance. Modify the memtable space using the `memtable_total_space_in_mb` property in the `cassandra.yaml` file.

Because MapReduce runs outside the JVM, changes to the JVM do not affect Analytics/Hadoop operations directly.

### How Cassandra uses memory

Using a java-based system like Cassandra, you can typically allocate about 8GB of memory on the heap before garbage collection pause time starts to become a problem. Modern machines have much more memory than that and Cassandra can make use of additional memory as page cache when files on disk are accessed. Allocating more than 8GB of memory on the heap poses a problem due to the amount of Cassandra metadata about data on disk. The Cassandra metadata resides in memory and is proportional to total data. Some of the components **grow proportionally to the size of total memory**.

In Cassandra 1.2 and later, the Bloom filter and compression offset map that store this metadata reside off-heap, greatly increasing the capacity per node of data that Cassandra can handle efficiently. The partition summary also resides off-heap.

### About the off-heap row cache

Cassandra can store cached rows in native memory, outside the Java heap. This results in both a smaller per-row memory footprint and reduced JVM heap requirements, which helps keep the heap size in the sweet spot for JVM garbage collection performance.



## Tuning Java garbage collection

Cassandra's GCInspector class logs information about garbage collection whenever a garbage collection takes longer than 200ms. Garbage collections that occur frequently and take a moderate length of time to complete (such as ConcurrentMarkSweep taking a few seconds), indicate that there is a lot of garbage collection pressure on the JVM. Remedies include adding nodes, lowering cache sizes, or adjusting the JVM options regarding garbage collection.

## JMX options

Cassandra exposes a number of statistics and management operations via Java Management Extensions (JMX). Java Management Extensions (JMX) is a Java technology that supplies tools for managing and monitoring Java applications and services. Any statistic or operation that a Java application has exposed as an MBean can then be monitored or manipulated using JMX. JConsole, the [nodetool utility](#), and DataStax OpsCenter are examples of JMX-compliant management tools.

By default, you can modify the following properties in the `conf/cassandra-env.sh` file to configure JMX to listen on port 7199 without authentication.

- `com.sun.management.jmxremote.port`  
The port on which Cassandra listens from JMX connections.
- `com.sun.management.jmxremote.ssl`  
Enable/disable SSL for JMX.
- `com.sun.management.jmxremote.authenticate`  
Enable/disable remote authentication for JMX.
- `-Djava.rmi.server.hostname`  
Sets the interface hostname or IP that JMX should use to connect. Uncomment and set if you are having trouble connecting.

The location of the `cassandra.yaml` file depends on the type of installation:

Package installations	<code>/etc/cassandra/cassandra.yaml</code>
Tarball installations	<code>install_location/resources/cassandra/conf/cassandra.yaml</code>

## Purging gossip state on a node

Correcting a problem in the gossip state.

### About this task

Gossip information is persisted locally by each node to use immediately on node restart without having to wait for gossip communications.

### Procedure

In the unlikely event you need to correct a problem in the gossip state:

1. Using MX4J or JConsole, connect to the node's JMX port and then use the JMX method `Gossiper.unsafeAssassinateEndpoints(ip_address)` to assassinate the problem node.  
This takes a few seconds to complete so wait for confirmation that the node is deleted.
2. If the JMX method above doesn't solve the problem, stop your client application from sending writes to the cluster.
3. Take the entire cluster offline:

## Operations

- a) **Drain** each node.

```
$ nodetool options drain
```

- b) Stop each node:

- Package installations:

```
$ sudo service cassandra stop
```

- Tarball installations:

```
$ sudo service cassandra stop
```

4. Clear the data from the `peers` directory:

```
$ sudo rm -r /var/lib/cassandra/data/system/peers/*
```

5. Clear the gossip state when the node starts:

- For tarball installations, you can use a command line option or edit the `cassandra-env.sh`. To use the command line:

```
$ install_location/bin/cassandra -Dcassandra.load_ring_state=false
```

- For package installations or if you are not using the command line option **above**, add the following line to the `cassandra-env.sh` file:

```
JVM_OPTS="$JVM_OPTS -Dcassandra.load_ring_state=false"
```

- Package installations: `/usr/share/cassandra/cassandra-env.sh`
- Tarball installations: `install_location/conf/cassandra-env.sh`

6. Bring the cluster online one node at a time, starting with the seed nodes.

- Package installations:

```
$ sudo service cassandra start
```

- Tarball installations:

```
$ cd install_location  
$ bin/cassandra
```

### What to do next

Remove the line you added in the `cassandra-env.sh` file.

## Repairing nodes

Node repair makes data on a replica consistent with data on other nodes.

Node repair makes data on a replica consistent with data on other nodes. Anti-entropy node repairs are important for every Cassandra cluster. Frequent data deletions and a node going down are common causes of inconsistency. You use the `nodetool repair` command to repair a node. There are several types of node repair:

- Sequential - One node is repaired after another, and done in full, all SSTables are repaired (default).
- Incremental - Persists already repaired data, which allows the repair process to stay performant and lightweight as datasets grow providing repairs are run frequently.
- Partitioner range - Repairs only the first range returned by the partitioner for a node. This repair type operates on each node in the cluster in succession without duplicating work

You can combine repair options, such as parallel and incremental repair. This combination does an incremental repair to all nodes at the same time. You can restrict repairs to local or other data centers or to

nodes between a certain token range. You can specify which nodes have the good data for replacing the outdated data.

### Incremental repair

The repair process involves computing a Merkle tree for each range of data on that node. The **Merkle tree** is a binary tree of hashes used by Cassandra for calculating the differences in datasets between nodes in a cluster. Each node involved in the repair has to construct its Merkle tree from all the SSTables it stores, making the calculation resource intensive.

To reduce the expense of constructing trees, Cassandra 2.1 introduces incremental repair. An incremental repair makes already repaired data persistent, and only calculates a Merkle tree for unrepaired SSTables.

### Merkle Trees of an Incremental Versus a Full Repair

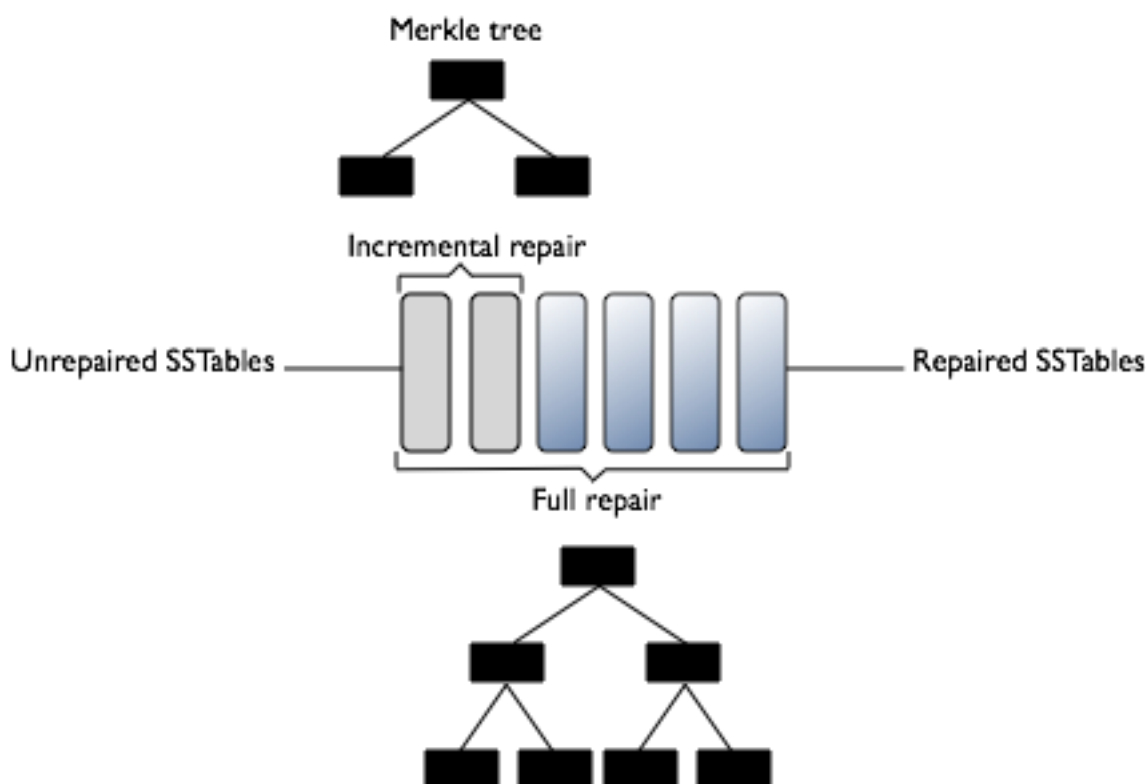

Reducing the size of the Merkle tree improves the performance of the incremental repair process, assuming repairs are run frequently.

Incremental repairs begin with the repair leader sending out a prepare message to its peers. Each node builds a Merkle tree from the unrepaired SSTables. After the leader receives a Merkle tree from each node, the leader compares the trees and issues streaming requests. Finally, the leader issues an anticompression command.

For more information about incremental repairs, see the ["More efficient repairs"](#) article.

### Anticompression

**Anticompression in Cassandra 2.1** is the process of segregating repaired and unrepaired ranges into separate SSTables unless the SSTable fits entirely within the repaired range. If the SSTable fits within the repaired range, Cassandra just updates the SSTable metadata.

Anticompression occurs after an **incremental repair**. Cassandra performs anticompression only on the SSTables that have a range of unrepaired data. If all node ranges are repaired, anticompression does not

## Operations

need to rewrite any data. During anticompaaction, size/date-tiered compaction and leveled compaction handle the segregation of the data differently.

- Size-tiered and date-tiered compaction splits repaired and unrepaired into separate pools for separate compactions. A major compaction generates two SSTables, one containing repaired data and one containing unrepaired data.
- Leveled compaction performs size-tiered compaction on unrepaired data. After repair completes, Cassandra moves data from the set of unrepaired SSTables to L0.

### Sequential versus parallel repair

By default, Cassandra 2.1 does a sequential repair of all SSTables, constructing the Merkle trees for one node after the other. Cassandra takes a snapshot of each replica immediately and then sequentially repairs each replica from the snapshots. For example, if you have RF=3 and A, B and C represents three replicas, this command takes a snapshot of each replica immediately and then sequentially repairs each replica from the snapshots (A<->B, A<->C, B<->C).

A parallel repair does the repair of nodes A, B, and C all at once. During this type of repair, the **dynamic snitch** maintains performance for your application using a replica in the snapshot that is not undergoing repair.

Snapshots are hardlinks to existing SSTables. Snapshots are immutable and require almost no disk space. Repair requires intensive disk I/O because validation compaction occurs during Merkle tree construction. For any given replica set, only one replica at a time performs the validation compaction.

### Partitioner range repair

Using the `nodetool repair -pr` (`-partitioner-range`) option repairs only the first range returned by the partitioner for a node. Other replicas for that range still have to perform the Merkle tree calculation, causing a validation compaction. Because all the replicas are compacting at the same time, all the nodes may be slow to respond for that portion of the data. This type of repair operates on each node in the cluster in succession without duplicating work.

Merkle trees do not have infinite resolution and Cassandra makes a tradeoff between the size and space. Currently, Cassandra uses a fixed depth of 15 for the tree (32K leaf nodes). For a node containing a million partitions with one damaged partition, about 30 partitions are streamed, which is the number that fall into each of the *leaves* of the tree. The problem gets worse when more partitions exist per node, and results in significant disk space usage and needless compaction. Generally, partitioner range repairs are not recommended.

### Repairing a subrange

To mitigate overstreaming, you can use subrange repair, but generally subrange repairs are not recommended. A subrange repair does a portion of the data belonging to the node. Because the Merkle tree precision is fixed, this effectively increases the overall precision.

To use subrange repair:

1. Use the Java `describe_splits` call to ask for a split containing 32K partitions.
2. Iterate throughout the entire range incrementally or in parallel. This completely eliminates the overstreaming behavior and wasted disk usage overhead.
3. Pass the tokens you received for the split to the `nodetool repair -st` (`-start-token`) and `-et` (`-end-token`) options.
4. Pass the `-local` (`-in-local-dc`) option to `nodetool` to repair only within the local data center. This reduces the cross data-center transfer load.

### Repair guidelines

Run repair in these situations:

- Daily if you run incremental repairs, weekly if you run full repairs.  
**Note:** Even if deletions never occur, schedule regular repairs. Setting a column to null is a delete.
- During node recovery. For example, when bringing a node back into the cluster after a failure.
- On nodes containing data that is not read frequently.
- To update data on a node that has been down.
- To recover missing data or corrupted SSTables. A non-incremental is required.
- To minimize impact, do not invoke more than one repair at a time.

Guidelines for running routine node repair include:

- Schedule regular repair operations for low-usage hours.
- A full repair is recommended to eliminate the need for anticompaaction.
- **Migrating to incremental repairs** is recommended if you use leveled compaction.
- The hard requirement for routine repair frequency is the value of `gc_grace_seconds`. Run a repair operation at least once on each node within this time period. Following this important guideline ensures that deletes are properly handled in the cluster.
- In systems that seldom delete or overwrite data, you can raise the value of `gc_grace_seconds` with minimal impact to disk space. A higher value schedules wider intervals between repair operations.
- To mitigate heavy disk usage, configure nodetool compaction throttling options (`setcompactionthroughput` and `setcompactionthreshold`) before running a repair.

### Migrating to incremental repairs

Migrating to incremental repairs by using the `sstablerepairedset` utility is recommended only under the following conditions:

- You are doing an incremental repair for the first time.
- You are using the leveled compaction strategy.

Full, sequential repairs are the default because until the first incremental repair, Cassandra does not know the repaired state of SSTables. After an incremental repair, anticompaaction marks SSTables as repaired or not. If you use the leveled compaction strategy and perform an incremental repair for the first time, Cassandra performs size-tiering on all SSTables because the repair/unrepaired status is unknown. This operation can take a long time. To save time, migrate to incremental repair one node at a time. The migration procedure, covered in the next section, uses utilities in the `tools/bin` directory of installations other than RHEL and Debian:

- `sstablemetadata` for checking the repaired or unrepaired status of an SSTable
- `sstablerepairedset` for manually marking an SSTable as repaired

The syntax of these commands is:

```
sstablemetadata <sstable filenames>
```

```
sstablerepairedset [--is-repaired | --is-unrepaired] [-f <sstable-list> | <sstables>]
```

In Cassandra 2.1.1, `sstablerepairedset` can take as arguments a list of SSTables on the command line or a file SSTables with a "-f" flag.

**Note:** In **RHEL** and **Debian** installations, you must install the tools packages.

This example shows how to use `sstablerepairedset` to clear the repaired state of an SSTable, rendering the SSTable unrepaired.

1. Stop the node.

## Operations

2. Run this command:

```
sstablerepairedset --is-unrepaired -f list_of_sstable_names.txt
```

3. Restart the node.

All data is changed to an unrepaired state.

### Procedure for migrating to incremental repairs

To migrate to incremental repair, one node at a time:

1. Disable compaction on the node using `nodetool disableautocompaction`.
2. Run the default full, sequential repair.
3. Stop the node.
4. Use the tool `sstablerepairedset` to mark all the SSTables that were created before you disabled compaction.
5. Restart cassandra

SSTables remain in a repaired state after running a full, but not a partition range, repair if you make no changes to the SSTables.

## Adding or removing nodes, data centers, or clusters

Topics for adding or removing nodes, data centers, or clusters.

### Adding nodes to an existing cluster

Steps to add nodes when using virtual nodes.

#### About this task

Virtual nodes (vnodes) greatly simplify adding nodes to an existing cluster:

- Calculating tokens and assigning them to each node is no longer required.
- Rebalancing a cluster is no longer necessary because a node joining the cluster assumes responsibility for an even portion of the data.

For a detailed explanation about how vnodes work, see [Virtual nodes](#).

If you are using racks, you can safely bootstrap two nodes at a time when both nodes are on the same rack.

**Note:** If you do not use vnodes, use [OpsCenter](#) to add capacity or see [Adding or replacing single-token nodes](#).

#### Procedure

Be sure to install the same version of Cassandra as is installed on the other nodes in the cluster. See [Installing prior releases](#).

1. Install Cassandra on the new nodes, but do not start Cassandra.

If you used the Debian install, Cassandra starts automatically and you must **stop** the node and **clear** the data.

2. Set the following properties in the `cassandra.yaml` and, depending on the snitch, the `cassandra-topology.properties` or `cassandra-rackdc.properties` configuration files:

- **auto\_bootstrap** - If this option has been set to false, you must set it to true. This option is not listed in the default `cassandra.yaml` configuration file and defaults to true.
- **cluster\_name** - The name of the cluster the new node is joining.

- `listen_address/broadcast_address` - Can usually be left blank. Otherwise, use IP address or host name that other Cassandra nodes use to connect to the new node.
- `endpoint_snitch` - The snitch Cassandra uses for locating nodes and routing requests.
- `num_tokens` - The number of vnodes to assign to the node. If the hardware capabilities vary among the nodes in your cluster, you can assign a proportional number of vnodes to the larger machines.
- `seed_provider` - The `-seeds` list in this setting determines which nodes the new node should contact to learn about the cluster and establish the gossip process.

**Note:** Seed nodes cannot `bootstrap`. Make sure the new node is not listed in the `-seeds` list. **Do not make all nodes seed nodes.** Please read [Internode communications \(gossip\)](#).

- Change any other non-default settings you have made to your existing cluster in the `cassandra.yaml` file and `cassandra-topology.properties` or `cassandra-rackdc.properties` files. Use the `diff` command to find and merge (by head) any differences between existing and new nodes.

The location of the `cassandra-topology.properties` file depends on the type of installation:

Package installations	<code>/etc/cassandra/cassandra-topology.properties</code>
Tarball installations	<code>install_location/conf/cassandra-topology.properties</code>

The location of the `cassandra-rackdc.properties` file depends on the type of installation:

Package installations	<code>/etc/cassandra/cassandra-rackdc.properties</code>
Tarball installations	<code>install_location/conf/cassandra-rackdc.properties</code>

The location of the `cassandra.yaml` file depends on the type of installation:

Package installations	<code>/etc/cassandra/cassandra.yaml</code>
Tarball installations	<code>install_location/resources/cassandra/conf/cassandra.yaml</code>

3. Use `nodetool status` to verify that the node is fully bootstrapped and all other nodes are up (UN) and not in any other state.
4. After all new nodes are running, run `nodetool cleanup` on each of the previously existing nodes to remove the keys that no longer belong to those nodes. Wait for cleanup to complete on one node before running `nodetool cleanup` on the next node.

Cleanup can be safely postponed for low-usage hours.

**Note:** Consistency issues might result when more than one node is added at a time. To assess the risks to your environment, see JIRA issues [CASSANDRA-2434](#) and [CASSANDRA-7069](#). Although adding multiple nodes at the same time is not a best practice, you can reduce data consistency risks by following these steps:

1. Before you add the nodes, turn off consistent range movements with the `-Dconsistent.rangemovement=false` property.

#### Package installations

Add the following option to the `/usr/share/cassandra/cassandra-env.sh` file:

```
JVM_OPTS="$JVM_OPTS -Dconsistent.rangemovement=false
```

#### Tarball installations

Start Cassandra with this option:

```
$ bin/cassandra -Dconsistent.rangemovement=false
```

2. Allow two minutes between node initializations.
3. After the nodes are added, turn consistent range movement back on.

### Adding a data center to a cluster

Steps for adding a data center to an existing cluster.

#### About this task

Steps for adding a data center to an existing cluster.

The location of the `cassandra.yaml` file depends on the type of installation:

Package installations	<code>/etc/cassandra/cassandra.yaml</code>
Tarball installations	<code>install_location/resources/cassandra/conf/cassandra.yaml</code>

#### Procedure

Be sure to install the same version of Cassandra as is installed on the other nodes in the cluster. See [Installing prior releases](#).

1. Ensure that you are using `NetworkTopologyStrategy` for all of your keyspaces.
2. For each node, set the following properties in the `cassandra.yaml` file:
  - a) Add (or edit) `auto_bootstrap: false`.

By default, this setting is true and not listed in the `cassandra.yaml` file. Setting this parameter to false prevents the new nodes from attempting to get all the data from the other nodes in the data center. When you run `nodetool rebuild` in the last step, each node is properly mapped.

- b) Set other properties, such as `-seeds` and `endpoint_snitch`, to match the cluster settings.

For more guidance, see [Initializing a multiple node cluster \(multiple data centers\)](#).

**Note:** Do not make all nodes seeds, see [Internode communications \(gossip\)](#).

- c) If you want to enable vnodes, set `num_tokens`.

The recommended value is 256. Do not set the `initial_token` parameter.

3. Update the relevant property file for snitch used on all servers to include the new nodes. You do not need to restart.

- `GossipingPropertyFileSnitch`: `cassandra-rackdc.properties`
- `PropertyFileSnitch`: `cassandra-topology.properties`

4. Ensure that your clients are configured correctly for the new cluster:

- If your client uses the DataStax Java, C#, or Python driver, set the load-balancing policy to `DCAwareRoundRobinPolicy` ([Java](#), [C#](#), [Python](#)).
- If you are using another client such as Hector, make sure it does not auto-detect the new nodes so that they aren't contacted by the client until explicitly directed. For example if you are using Hector, use `setHostConfig.setAutoDiscoverHosts(false)`; If you are using Astyanax, use `ConnectionPoolConfigurationImpl.setLocalDatacenter("<data center name">)` to ensure you are connecting to the specified data center.



- If you are using Astyanax 2.x, with integration with the DataStax Java Driver 2.0, you can set the load-balancing policy to `DCAwareRoundRobinPolicy` by calling `JavaDriverConfigBuilder.withLoadBalancingPolicy()`.

```
AstyanaxContext<Keyspace> context = new AstyanaxContext.Builder()
    ...
    .withConnectionPoolConfiguration(new JavaDriverConfigBuilder()
        .withLoadBalancingPolicy(new TokenAwarePolicy(new
            DCAwareRoundRobinPolicy()))
        .build())
    ...
```

5. If using a QUORUM **consistency level** for reads or writes, check the LOCAL\_QUORUM or EACH\_QUORUM consistency level to see if the level meets your requirements for multiple data centers.
6. Start Cassandra on the new nodes.
7. After all nodes are running in the cluster:
  - a) Change the **keyspace properties** to specify the desired replication factor for the new data center.
 

For example, set strategy options to DC1:2, DC2:2.

For more information, see [ALTER KEYSPACE](#).
  - b) Run `nodetool rebuild` specifying the existing data center on all nodes in the new data center:

```
nodetool rebuild -- name_of_existing_data_center
```

Otherwise, requests to the new data center with LOCAL\_ONE or ONE consistency levels may fail if the existing data centers are not completely in-sync.

You can run `rebuild` on one or more nodes at the same time. The choices depends on whether your cluster can handle the extra IO and network pressure of running on multiple nodes. Running on one node at a time has the least impact on the existing cluster.

**Attention:** If you don't specify the existing data center in the command line, the new nodes will appear to rebuild successfully, but will not contain any data.

8. Change to true or remove **auto\_bootstrap: false** in the `cassandra.yaml` file.

Returns this parameter to its normal setting so the nodes can get all the data from the other nodes in the data center if restarted.

## Replacing a dead node or dead seed node

Steps to replace a node that has died for some reason, such as hardware failure.

### About this task

Steps to replace a node that has died for some reason, such as hardware failure. Prepare and start the replacement node, then attach it to the cluster. After the replacement node is running in the cluster, **remove the dead node**.

### Replacing a dead seed node

1. Promote an existing node to a seed node by adding its IP address to `-seeds` list and remove (demote) the IP address of the dead seed node from the `cassandra.yaml` file for each node in the cluster.
2. Replace the dead node, as described in the next section.

### Replacing a dead node

#### Procedure

Be sure to install the same version of Cassandra as is installed on the other nodes in the cluster. See [Installing prior releases](#).

1. Confirm that the node is dead using `nodetool status`:

The `nodetool` command shows a down status for the dead node (DN):

```
paul@ubuntu:/cassandra-2.1.0$ bin/nodetool status
Datacenter: datacenter1
*****
Status=Up/Down
// StateNormal/Leaving/Joining/Moving
-- Address          Load          Tokens       Owns    Host ID                               Rack
UN 10.196.171.100    53.98 KB     256          0.8%    a9fa31c7-f3c0-44d1-b8e7-a2628867840c rack1
UN 10.196.14.48     93.02 KB     256          9.9%    f5bb140c-d051-475c-a44f-9facf2f1ad6e rack1
DN 10.196.14.239    ?            256          0.2%    null
```

2. Note the `Address` of the dead node; it is used in [step 5](#).
3. Install Cassandra on the new node, but do not start Cassandra.

If you used the Debian/Ubuntu install, Cassandra starts automatically and you must `stop` the node and `clear` the data.

4. Set the following properties in the `cassandra.yaml` and, depending on the snitch, the `cassandra-topology.properties` or `cassandra-rackdc.properties` configuration files:

- `auto_bootstrap` - If this option has been set to false, you must set it to true. This option is not listed in the default `cassandra.yaml` configuration file and defaults to true.
- `cluster_name` - The name of the cluster the new node is joining.
- `listen_address/broadcast_address` - Can usually be left blank. Otherwise, use IP address or host name that other Cassandra nodes use to connect to the new node.
- `endpoint_snitch` - The snitch Cassandra uses for locating nodes and routing requests.
- `num_tokens` - The number of vnodes to assign to the node. If the hardware capabilities vary among the nodes in your cluster, you can assign a proportional number of vnodes to the larger machines.
- `seed_provider` - The `-seeds` list in this setting determines which nodes the new node should contact to learn about the cluster and establish the gossip process.

**Note:** Seed nodes cannot `bootstrap`. Make sure the new node is not listed in the `-seeds` list. **Do not make all nodes seed nodes.** Please read [Internode communications \(gossip\)](#).

- Change any other non-default settings you have made to your existing cluster in the `cassandra.yaml` file and `cassandra-topology.properties` or `cassandra-rackdc.properties` files. Use the `diff` command to find and merge (by head) any differences between existing and new nodes.
5. Start the replacement node with the `replace_address` option:
    - Package installations: Add the following option to `/usr/share/cassandra/cassandra-env.sh` file:

```
JVM_OPTS="$JVM_OPTS -Dcassandra.replace_address=address_of_dead_node
```

- Tarball installations: Start Cassandra with this option:

```
$ sudo bin/cassandra -Dcassandra.replace_address=address_of_dead_node
```

6. If using a packaged install, after the new node finishes bootstrapping, remove the option you added in [step 5](#).

#### What to do next

- Remove the old node's IP address from the `cassandra-topology.properties` or `cassandra-rackdc.properties` file.

**Caution:** Wait at least 72 hours to ensure that old node information is removed from `gossip`. If removed from the property file too soon, problems may result.

- **Remove the node.**

**Caution:** Wait at least 72 hours to ensure that old node information is removed from `gossip`. If removed from the property file too soon, problems may result.

The location of the `cassandra-topology.properties` file depends on the type of installation:

Package installations	<code>/etc/cassandra/cassandra-topology.properties</code>
Tarball installations	<code>install_location/conf/cassandra-topology.properties</code>

The location of the `cassandra-rackdc.properties` file depends on the type of installation:

Package installations	<code>/etc/cassandra/cassandra-rackdc.properties</code>
Tarball installations	<code>install_location/conf/cassandra-rackdc.properties</code>

The location of the `cassandra.yaml` file depends on the type of installation:

Package installations	<code>/etc/cassandra/cassandra.yaml</code>
Tarball installations	<code>install_location/resources/cassandra/conf/cassandra.yaml</code>

## Replacing a running node

Steps to replace a node with a new node, such as when updating to newer hardware or performing proactive maintenance.

### About this task

Steps to replace a node with a new node, such as when updating to newer hardware or performing proactive maintenance.

You must prepare and start the replacement node, integrate it into the cluster, and then decommission the old node.

**Note:** To change the IP address of a node, simply change the IP of node and then restart Cassandra. If you change the IP address of a seed node, you must update the `-seeds` parameter in the `seed_provider` for each node in the `cassandra.yaml` file.

The location of the `cassandra.yaml` file depends on the type of installation:

Package installations	<code>/etc/cassandra/cassandra.yaml</code>
Tarball installations	<code>install_location/resources/cassandra/conf/cassandra.yaml</code>

### Procedure

Be sure to install the same version of Cassandra as is installed on the other nodes in the cluster. See [Installing prior releases](#).

1. Prepare and start the replacement node, as described in [Adding nodes to an existing cluster](#).

## Operations

**Note:** If not using vnodes, see [Adding or replacing single-token nodes](#).

2. Confirm that the replacement node is alive:

- Run `nodetool ring` if not using vnodes.
- Run `nodetool status` if using vnodes.

The status should show:

- `nodetool ring: Up`
- `nodetool status: UN`

3. Note the `Host ID` of the node; it is used in the next step.

4. Using the Host ID of the original node, decommission the original node from the cluster using the `nodetool decommission` command.

## Moving a node from one rack to another

A common task is moving a node from one rack to another. For example, when using `GossipPropertyFileSnitch`, a common error is mistakenly placing a node in the wrong rack. To correct the error, use one of the following procedures.

- The preferred method is to [decommission the node](#) and re-add it to the correct rack and data center.
  - This method takes longer to complete than the alternative method. Data is moved that the decommissioned node doesn't need anymore. Then the node gets new data while bootstrapping. The alternative method does both operations simultaneously.
- An alternative method is to [update the node's topology](#) and restart the node. Once the node is up, run a [full repair](#) on the cluster.

**Note:** This method is not preferred because until the repair is completed, the node might blindly handle requests for data the node doesn't yet have.

## Decommissioning a data center

Steps to properly remove a data center so no information is lost.

### About this task

Steps to properly remove a data center so no information is lost.

### Procedure

1. Make sure no clients are still writing to any nodes in the data center.
2. Run a full repair with `nodetool repair`.

This ensures that all data is propagated from the data center being decommissioned.

3. [Change all keyspaces](#) so they no longer reference the data center being removed.
4. Run `nodetool decommission` on every node in the data center being removed.

## Removing a node

Reduce the size of a data center.

### About this task

Use these instructions when you want to remove nodes to reduce the size of your cluster, not for [replacing a dead node](#).

**Attention:** If you are not using [virtual nodes](#) (vnodes), you must rebalance the cluster.

## Procedure

1. Check whether the node is up or down using `nodetool status`:

The `nodetool` command shows the status of the node (UN=up, DN=down):

```

paul@ubuntu:/cassandra-1.2.0$ bin/nodetool status
Datacenter: datacenter1
=====
Status=Up/Down
// State=Normal/Leaving/Joining/Moving
-- Address          Load        Tokens      Owns    Host ID                               Rack
UN 10.194.171.160    53.98 KB    256         0.8%    a9fa31c7-f3c0-44d1-b8e7-a2628867840c  rack1
UN 10.190.14.48      93.02 KB    256         9.9%    f5bb140c-d51-475c-a44f-9facf2f1a0e    rack1
DN 10.190.14.239     7           256         8.2%    null                                     rack1

```

2. If the node is up, run `nodetool decommission`.

This assigns the ranges that the node was responsible for to other nodes and replicates the data appropriately.

Use `nodetool netstats` to monitor the progress.

3. If the node is down:
  - If the cluster uses `vnodes`, remove the node using the `nodetool removemode` command.
  - If the cluster does not use `vnodes`, before running the `nodetool removemode` command, **adjust your tokens to evenly distribute** the data across the remaining nodes to avoid creating a hot spot.
4. If the node does not stop streaming data to other nodes because gossip has stale state data for the node, **assassinate the node**.

## Switching snitches

Steps for switching snitches.

### About this task

Because `snitches` determine how Cassandra distributes replicas, the procedure to switch snitches depends on whether or not the topology of the cluster will change:

- If data has not been inserted into the cluster, there is no change in the network topology. This means that you only need to set the snitch; no other steps are necessary.
- If data has been inserted into the cluster, it's possible that the topology has changed and you will need to perform additional steps.

A change in topology means that there is a change in the data centers and/or racks where the nodes are placed. Topology changes may occur when the replicas are placed in different places by the new snitch. Specifically, the replication strategy places the replicas based on the information provided by the new snitch. The following examples demonstrate the differences:

- **No topology change**

Suppose you have 5 nodes using the `SimpleSnitch` in a single data center and you change to 5 nodes in 1 data center and 1 rack using a network snitch such as the `GossipingPropertyFileSnitch`.

- **Topology change**

Suppose you have 5 nodes using the `SimpleSnitch` in a single data center and you change to 5 nodes in 2 data centers using the `PropertyFileSnitch`.

**Note:** If splitting from one data center to two, you need to change the schema for the `keyspace` that are splitting. Additionally, the data center names must change accordingly.

- **Topology change**

Suppose you have 5 nodes using the `SimpleSnitch` in a single data center and you change to 5 nodes in 1 data center and 2 racks using the `RackInferringSnitch`.

## Procedure

1. Create a properties file with data center and rack information.

## Operations

- `cassandra-rackdc.properties`  
`GossipingPropertyFileSnitch`, `Ec2Snitch`, and `Ec2MultiRegionSnitch` only.
- `cassandra-topology.properties`

All other network snitches.

2. Copy the `cassandra-rackdc.properties` or `cassandra-topology.properties` file to the Cassandra configuration directory on all the cluster's nodes. They won't be used until the new snitch is enabled.

The location of the `cassandra-topology.properties` file depends on the type of installation:

Package installations	<code>/etc/cassandra/cassandra-topology.properties</code>
Tarball installations	<code>install_location/conf/cassandra-topology.properties</code>

The location of the `cassandra-rackdc.properties` file depends on the type of installation:

Package installations	<code>/etc/cassandra/cassandra-rackdc.properties</code>
Tarball installations	<code>install_location/conf/cassandra-rackdc.properties</code>

The location of the `cassandra.yaml` file depends on the type of installation:

Package installations	<code>/etc/cassandra/cassandra.yaml</code>
Tarball installations	<code>install_location/resources/cassandra/conf/cassandra.yaml</code>

3. Change the snitch for each node in the cluster in the node's `cassandra.yaml` file. For example:

```
endpoint_snitch: GossipingPropertyFileSnitch
```

4. If the topology has not changed, you can restart each node one at a time.

Any change in the `cassandra.yaml` file requires a node restart.

5. If the topology of the network has changed:
  - a) Shut down all the nodes, then restart them.
  - b) Run a `sequential repair` and `nodetool cleanup` on each node.

## Edge cases for transitioning or migrating a cluster

Unusual migration scenarios without interruption of service.

### About this task

The information in this topic is intended for the following types of scenarios (without any interruption of service):

- Transition a cluster on EC2 to a cluster on Amazon virtual private cloud (VPC).
- Migrate from a cluster when the network separates the current cluster from the future location.
- Migrate from an early Cassandra cluster to a recent major version.

### Procedure

The following method ensures that if something goes wrong with the new cluster, you still have the existing cluster until you no longer need it.

1. Set up and configure the new cluster as described in [Provisioning a new cluster](#).

**Note:** If you're not using vnodes, be sure to configure the token ranges in the new nodes to match the ranges in the old cluster.

2. Set up the schema for the new cluster using [CQL](#).
3. Configure your client to write to both clusters.

Depending on how the writes are done, code changes may be needed. Be sure to use identical consistency levels.

4. Ensure that the data is flowing to the new nodes so you won't have any gaps when you copy the snapshots to the new cluster in step 6.
5. [Snapshot](#) the old EC2 cluster.
6. Copy the data files from your keyspaces to the nodes.

- If not using vnodes and the if the node ratio is 1:1, it's simpler and more efficient to simply copy the data files to their matching nodes.
- If the clusters are different sizes or if you are using vnodes, use the [Cassandra bulk loader \(sstableloader\)](#) (sstableloader).

7. You can either switch to the new cluster all at once or perform an incremental migration.

For example, to perform an incremental migration, you can set your client to designate a percentage of the reads that go to the new cluster. This allows you to test the new cluster before decommissioning the old cluster.

8. Decommission the old cluster:
  - a) [Remove the cluster from the OpsCenter](#).
  - b) Remove the nodes.

## Adding or replacing single-token nodes

Steps for adding or replacing nodes in single-token architecture clusters.

### About this task

This topic applies only to clusters using single-token architecture, not vnodes.

### About adding Capacity to an Existing Cluster

Cassandra allows you to add capacity to a cluster by introducing new nodes to the cluster in stages and by adding an entire data center. When a new node joins an existing cluster, it needs to know:

- Its position in the ring and the range of data it is responsible for, which is assigned by the [initial\\_token](#) and the [partitioner](#).
- The [seed](#) nodes to contact for learning about the cluster and establish the [gossip](#) process.
- The name of the cluster it is joining and how the node should be addressed within the cluster.
- Any other non-default settings made to `cassandra.yaml` on your existing cluster.

When you add one or more nodes to a cluster, you must calculate the tokens for the new nodes. Use one of the following approaches:

#### Add capacity by doubling the cluster size

Adding capacity by doubling (or tripling or quadrupling) the number of nodes is less complicated when assigning tokens. Existing nodes can keep their existing token assignments, and new nodes are assigned tokens that bisect (or trisect) the existing token ranges. For example, when you generate tokens for six nodes, three of the generated token values will be the same as if you generated for three nodes. To clarify, you first obtain the token values that are already in use, and then assign the newly calculated token values to the newly added nodes.

#### Recalculate new tokens for all nodes and move nodes around the ring

## Operations

When increases capacity by a non-uniform number of nodes, you must recalculate tokens for the entire cluster, and then use `nodetool move` to assign the new tokens to the existing nodes. After all nodes are restarted with their new token assignments, run a `nodetool cleanup` to remove unused keys on all nodes. These operations are resource intensive and should be done during low-usage times.

### Add one node at a time and leave the `initial_token` property empty

When the `initial_token` is empty, Cassandra splits the token range of the heaviest loaded node and places the new node into the ring at that position. This approach is unlikely to result in a perfectly balanced ring, but will alleviate hot spots.

### Adding Nodes to a Cluster

1. Install Cassandra on the new nodes, but do not start them.
2. Calculate the tokens for the nodes based on the expansion strategy you are using the `Token Generating Tool`. *You can skip this step if you want the new nodes to automatically pick a token range when joining the cluster.*
3. Set the `cassandra.yaml` for the new nodes.
4. Set the `initial_token` according to your token calculations (or leave it unset if you want the new nodes to automatically pick a token range when joining the cluster).
5. Start Cassandra on each new node. Allow **two** minutes between node initializations. You can monitor the startup and data streaming process using `nodetool netstats`.
6. After the new nodes are fully bootstrapped, assign the new `initial_token` property value to the nodes that required new tokens, and then run `nodetool move new_token`, one node at a time.
7. After all nodes have their new tokens assigned, run `nodetool cleanup` one node at a time for each node. Wait for cleanup to complete before doing the next node. This step removes the keys that no longer belong to the previously existing nodes.

**Note:** Cleanup may be safely postponed for low-usage hours.

### Adding a Data Center to a Cluster

Before starting this procedure, please read the guidelines in `Adding Capacity to an Existing Cluster` above.

1. Ensure that you are using `NetworkTopologyStrategy` for all of your keyspaces.
2. For each new node, edit the configuration properties in the `cassandra.yaml` file:
  - Set `auto_bootstrap` to `False`.
  - Set the `initial_token`. Be sure to offset the tokens in the new data center, see `Generating tokens`.
  - Set the `cluster_name`.
  - Set any other non-default settings.
  - Set the `seed lists`. Every node in the cluster must have the same list of seeds and include at least one node from each data center. Typically one to three seeds are used per data center.
3. Update either the `cassandra-topology.properties` (`PropertyFileSnitch`) or `cassandra-rackdc.properties` (`GossipingPropertyFileSnitch`) on all servers to include the new nodes. You do not need to restart.

The location of the `conf` directory depends on the type of installation:

- Package installations: `/etc/cassandra/conf`
  - Tarball installations: `install_location/conf`
4. Ensure that your client does not auto-detect the new nodes so that they aren't contacted by the client until explicitly directed. For example in Hector, set

```
hostConfig.setAutoDiscoverHosts(false);
```



5. If using a QUORUM consistency level for reads or writes, check the LOCAL\_QUORUM or EACH\_QUORUM consistency level to make sure that the level meets the requirements for multiple data centers.
6. Start the new nodes.
7. After all nodes are running in the cluster:
  - a. Change the replication factor for your keyspace for the expanded cluster.
  - b. Run `nodetool rebuild` on each node in the new data center.

## Replacing a Dead Node

1. Confirm that the node is dead using the `nodetool ring` command on any live node in the cluster.

The `nodetool ring` command shows a *Down* status for the token value of the dead node:

```

$ nodetool ring -h localhost
Address DC Rack Status State Load Owns Token
10.46.123.11 datacenter1 rack1 Up Normal 179.58 KB 16.67K 0
10.46.123.12 datacenter1 rack1 Down Normal 315.21 KB 16.67K 28356863910078205288614550619314017621
10.46.123.13 datacenter1 rack1 Up Normal 267.71 KB 16.67K 56713727820156418577229181238628035242
10.46.123.14 datacenter1 rack1 Up Normal 315.21 KB 16.67K 85070911730234615805843051857942052863
10.46.123.15 datacenter1 rack1 Up Normal 292.36 KB 16.67K 113424550403126115445402477256070445
10.46.123.16 datacenter1 rack1 Up Normal 300.82 KB 16.67K 14178431950839102644307275389657088106

```

2. Install **Cassandra** on the replacement node.
3. Remove any preexisting Cassandra data on the replacement node:

```
$ sudo rm -rf /var/lib/cassandra/*
```

4. Set `auto_bootstrap: true`. (If `auto_bootstrap` is not in the `cassandra.yaml` file, it automatically defaults to `true`.)
5. Set the `initial_token` in the `cassandra.yaml` file to the value of the dead node's token -1. Using the value from the above graphic, this is `28356863910078205288614550619314017621-1`:

```
initial_token: 28356863910078205288614550619314017620
```

6. Configure any non-default settings in the node's `cassandra.yaml` to match your existing cluster.
7. Start the new node.
8. After the new node has finished bootstrapping, check that it is marked up using the `nodetool ring` command.
9. Run `nodetool repair` on each keyspace to ensure the node is fully consistent. For example:

```
$ nodetool repair -h 10.46.123.12 keyspace_name
```

10. Remove the dead node.

The location of the `cassandra.yaml` file depends on the type of installation:

Package installations	<code>/etc/cassandra/cassandra.yaml</code>
Tarball installations	<code>install_location/resources/cassandra/conf/cassandra.yaml</code>

# Backing up and restoring data

Cassandra backs up data by taking a snapshot of all on-disk data files (SSTable files) stored in the data directory.

## About snapshots

A brief description of how Cassandra backs up data.

Cassandra backs up data by taking a snapshot of all on-disk data files (SSTable files) stored in the data directory. You can take a snapshot of all keyspaces, a single keyspace, or a single table while the system is online.

Using a parallel ssh tool (such as pssh), you can snapshot an entire cluster. This provides an *eventually consistent* backup. Although no one node is guaranteed to be consistent with its replica nodes at the time a snapshot is taken, a restored snapshot resumes consistency using Cassandra's built-in consistency mechanisms.

After a system-wide snapshot is performed, you can enable incremental backups on each node to backup data that has changed since the last snapshot: each time an SSTable is flushed, a hard link is copied into a `/backups` subdirectory of the data directory (provided JNA is enabled).

**Note:** If JNA is enabled, snapshots are performed by hard links. If not enabled, I/O activity increases as the files are copied from one location to another, which significantly reduces efficiency.

## Taking a snapshot

Steps for taking a global snapshot or per node.

### About this task

Snapshots are taken per node using the `nodetool snapshot` command. To take a global snapshot, run the `nodetool snapshot` command using a parallel ssh utility, such as pssh.

A snapshot first flushes all in-memory writes to disk, then makes a hard link of the SSTable files for each keyspace. You must have enough free disk space on the node to accommodate making snapshots of your data files. A single snapshot requires little disk space. However, snapshots can cause your disk usage to grow more quickly over time because a snapshot prevents old obsolete data files from being deleted. After the snapshot is complete, you can move the backup files to another location if needed, or you can leave them in place.

**Note:** Cassandra can only restore data from a snapshot when the table schema exists. It is recommended that you also backup the schema.

### Procedure

Run the `nodetool snapshot` command, specifying the hostname, JMX port, and keyspace. For example:

```
$ nodetool -h localhost -p 7199 snapshot mykeyspace
```

### Results

The snapshot is created in `data_directory_location/keyspace_name/table_name-UUID/snapshots/snapshot_name` directory. Each snapshot directory contains numerous `.db` files that contain the data at the time of the snapshot.

For example:

Package installations:

```
/var/lib/cassandra/data/mykeyspace/users-081a1500136111e482d09318a3b15cc2/
snapshots/1406227071618/mykeyspace-users-ka-1-Data.db
```

Tarball installations:

```
install_location/data/data/mykeyspace/
users-081a1500136111e482d09318a3b15cc2/snapshots/1406227071618/mykeyspace-
users-ka-1-Data.db
```

## Deleting snapshot files

Steps to delete snapshot files.

### About this task

When taking a snapshot, previous snapshot files are not automatically deleted. You should remove old snapshots that are no longer needed.

The `nodetool clearsnapshot` command removes all existing snapshot files from the snapshot directory of each keyspace. You should make it part of your back-up process to clear old snapshots before taking a new one.

### Procedure

To delete all snapshots for a node, run the `nodetool clearsnapshot` command. For example:

```
$ nodetool -h localhost -p 7199 clearsnapshot
```

To delete snapshots on all nodes at once, run the `nodetool clearsnapshot` command using a parallel `ssh` utility.

## Enabling incremental backups

Steps to enable incremental backups. When incremental backups are enabled, Cassandra hard-links each flushed SSTable to a backups directory under the keyspace data directory.

### About this task

When incremental backups are enabled (disabled by default), Cassandra hard-links each flushed SSTable to a backups directory under the keyspace data directory. This allows storing backups offsite without transferring entire snapshots. Also, incremental backups combine with snapshots to provide a dependable, up-to-date backup mechanism.

As with snapshots, Cassandra does not automatically clear incremental backup files. DataStax recommends setting up a process to clear incremental backup hard-links each time a new snapshot is created.

The location of the `cassandra.yaml` file depends on the type of installation:

Package installations	<code>/etc/cassandra/cassandra.yaml</code>
Tarball installations	<code>install_location/resources/cassandra/conf/cassandra.yaml</code>

## Backing up and restoring data

### Procedure

Edit the `cassandra.yaml` configuration file on each node in the cluster and change the value of `incremental_backups` to `true`.

## Restoring from a snapshot

Methods for restoring from a snapshot.

### About this task

Restoring a keyspace from a snapshot requires all snapshot files for the table, and if using incremental backups, any incremental backup files created after the snapshot was taken.

Generally, before restoring a snapshot, you should `truncate` the table. If the backup occurs before the `delete` and you restore the backup after the delete without first truncating, you do not get back the original data (row). Until compaction, the tombstone is in a different SSTable than the original row, so restoring the SSTable containing the original row does not remove the tombstone and the data still appears to be deleted.

Cassandra can only restore data from a snapshot when the table schema exists. If you have not backed up the schema, you can do either of the following:

- Method 1
  1. Restore the snapshot, as described below.
  2. Recreate the schema.
- Method 2
  1. Recreate the schema.
  2. Restore the snapshot, as described below.
  3. Run `nodetool refresh`.

### Procedure

You can restore a snapshot in several ways:

- Use the `sstableloader` tool.
- Copy the snapshot SSTable directory (see [Taking a snapshot](#)) to the `data/keyspace/table_name-UUID` directory and then call the JMX method `loadNewSSTables()` in the column family MBean for each column family through JConsole. You can use `nodetool refresh` instead of the `loadNewSSTables()` call.

The location of the data directory depends on the type of installation:

- Package installations: `/var/lib/cassandra/data`
- Tarball installations: `install_location/data/data`

The tokens for the cluster you are restoring must match exactly the tokens of the backed-up cluster at the time of the snapshot. Furthermore, the snapshot must be copied to the correct node with matching tokens matching. If the tokens do not match, or the number of nodes do not match, use the `sstableloader` procedure.

- Use the Node Restart Method described below.

## Node restart method

Steps for restoring a snapshot. This method requires shutting down and starting nodes.

### About this task

If restoring a single node, you must first shutdown the node. If restoring an entire cluster, you must shut down all nodes, restore the snapshot data, and then start all nodes again.

**Note:** Restoring from snapshots and incremental backups temporarily causes intensive CPU and I/O activity on the node being restored.

The location of the `commitlog` directory depends on the type of installation:

Package installations	<code>/var/lib/cassandra/commitlog</code>
Tarball installations	<code>install_location/data/commitlog</code>

### Procedure

1. Shut down the node.
2. Clear all files in the `commitlog` directory.

This prevents the `commitlog` replay from putting data back, which would defeat the purpose of restoring data to a particular point in time.

3. Delete all `*.db` files in `data_directory_location/keyspace_name/keyspace_name-keyspace_name` directory, but **DO NOT** delete the `/snapshots` and `/backups` subdirectories. where `data_directory_location` is:

- Package installations: `/var/lib/cassandra/data`
- Tarball installations: `install_location/data/data`

4. Locate the most recent snapshot folder in this directory:

```
data_directory_location/keyspace_name/table_name-UUID/
snapshots/snapshot_name
```

5. Copy its contents into this directory:

```
data_directory_location/keyspace_name/table_name-UUID directory.
```

6. If using incremental backups, copy all contents of this directory:

```
data_directory_location/keyspace_name/table_name-UUID/backups
```

7. Paste it into this directory:

```
data_directory_location/keyspace_name/table_name-UUID
```

8. Restart the node.

Restarting causes a temporary burst of I/O activity and consumes a large amount of CPU resources.

9. Run `nodetool repair`.

## Restoring a snapshot into a new cluster

Steps for restoring a snapshot by recovering the cluster into another newly created cluster.

### About this task

Suppose you want to copy a snapshot of SSTable data files from a three node Cassandra cluster with `vnodes` enabled (256 tokens) and recover it on another newly created three node cluster (256 tokens). The token ranges will not match so you need to specify the tokens for the new cluster that were used in the old cluster.

## Backing up and restoring data

**Note:** This procedure assumes you are familiar with [restoring a snapshot](#) and configuring and initializing a cluster. If not, see [Initializing a cluster](#).

The location of the `cassandra.yaml` file depends on the type of installation:

Package installations	<code>/etc/cassandra/cassandra.yaml</code>
Tarball installations	<code>install_location/resources/cassandra/conf/cassandra.yaml</code>

### Procedure

To recover the snapshot on the new cluster:

1. From the old cluster, retrieve the list of tokens associated with each node's IP:

```
$ nodetool ring | grep ip_address_of_node | awk '{print $NF ", "}' | xargs
```

2. In the `cassandra.yaml` file for each node in the new cluster, add the list of tokens you obtained in the previous step to the `initial_token` parameter using the same `num_tokens` setting as in the old cluster.
3. Make any other necessary changes in the `cassandra.yaml` and property files so that the new nodes match the old cluster settings.
4. Clear the system table data from each new node:

```
$ sudo rm -rf /var/lib/cassandra/data/system/*
```

This allows the new nodes to use the initial tokens defined in the `cassandra.yaml` when they restart.

5. Restore the SSTable files snapshotted from the old cluster onto the new cluster using the same directories. Otherwise the new cluster does not have data to read in when you restart the nodes.
6. Start each node using the specified list of token ranges in `cassandra.yaml`:

```
initial_token: -9211270970129494930, -9138351317258731895,  
-8980763462514965928, ...
```

This allows Cassandra to read the SSTable snapshot from the old cluster.

## Recovering from a single disk failure using JBOD

Recovering from a single disk failure in a disk array using JBOD.

### About this task

How to recover from a single disk failure in a disk array using JBOD (just a bunch of disks).

### Node can restart

1. **Stop Cassandra** and shut down the node.
2. Replace the failed disk.
3. Start the node and **Cassandra**.
4. Run `nodetool repair` on the node.

### Node cannot restart

If the node cannot restart, it is possible the system directory is corrupted. If the node cannot restart after completing these steps, see [Replacing a dead node or dead seed node](#).

If using the node uses `vnodes`:

1. **Stop Cassandra** and shut down the node.

2. Replace the failed disk.
3. On a healthy node run the following command:

```
$ nodetool ring | grep ip_address_of_node | awk ' {print $NF ","}' | xargs
```

4. On the node with the new disk, add the list of tokens from the previous step (separated by commas), under `initial_token` in the `cassandra.yaml` file.
5. Clear each `system` directory for every functioning drive:

Assuming disk1 has failed and the `data_file_directories` setting in the `cassandra.yaml` for each drive is:

```
-/mnt1/cassandra/data
-/mnt2/cassandra/data
-/mnt3/cassandra/data
```

Run the following commands:

```
$ rm -fr /mnt2/cassandra/data/system
$ rm -fr /mnt3/cassandra/data/system
```

6. Start the node and **Cassandra**.
7. Run `nodetool repair`.
8. After the node is fully integrated into the cluster, it is recommended to return to normal vnode settings:
  - `num_tokens`: `number_of_tokens`
  - `#initial_token`

If the node uses assigned tokens (single-token architecture):

1. **Stop Cassandra** and shut down the node.
2. Replace the failed disk.
3. Clear each `system` directory for every functioning drive:

Assuming disk1 has failed and the `data_file_directories` setting in the `cassandra.yaml` for each drive is:

```
-/mnt1/cassandra/data
-/mnt2/cassandra/data
-/mnt3/cassandra/data
```

Run the following commands:

```
$ rm -fr /mnt2/cassandra/data/system
$ rm -fr /mnt3/cassandra/data/system
```

4. Start the node and **Cassandra**.
5. Run `nodetool repair` on the node.

The location of the `cassandra.yaml` file depends on the type of installation:

Package installations	<code>/etc/cassandra/cassandra.yaml</code>
Tarball installations	<code>install_location/resources/cassandra/conf/cassandra.yaml</code>

## Cassandra tools

Topics for Cassandra tools.

### The nodetool utility

A command line interface for managing a cluster.

The nodetool utility is a command line interface for managing a cluster.

#### Command format

- Package installations: `nodetool [(-h <host> | --host <host>)] [(-p <port> | --port <port>)] [(-pwf <passwordFilePath> | --password-file <passwordFilePath>)] [(-u <username> | --username <username>)] [(-pw <password> | --password <password>)] <command> [<args>]`
- Tarball installations: Execute the command from `install_location/bin`
- If a username and password for RMI authentication are set explicitly in the `cassandra-env.sh` file for the host, then you must specify credentials.

The repair and rebuild commands can affect multiple nodes in the cluster.

Most nodetool commands operate on a single node in the cluster if `-h` is not used to identify one or more other nodes. If the node from which you issue the command is the intended target, you do not need the `-h` option to identify the target; otherwise, for remote invocation, identify the target node, or nodes, using `-h`.

#### Getting nodetool help

```
nodetool help
```

Provides a listing of nodetool commands.

```
nodetool help command name
```

Provides help on a specific command. For example

```
$ nodetool help upgradesstables
```

### nodetool cfhistograms

Provides statistics about a table that could be used to plot a frequency function.

Provides statistics about a table that could be used to plot a frequency function.

#### Synopsis

```
$ nodetool <options> cfhistograms -- <keyspace> <table>
```

- options are:
  - `(-h | --host) <host name> | <ip address>`
  - `(-p | --port) <port number>`
  - `(-pw | --password) <password >`
  - `(-u | --username) <user name>`
  - `(-pwf <passwordFilePath> | --password-file <passwordFilePath> )`
- `--` separates an option from an argument that could be mistaken for a option.
- `keyspace` is the name of a keyspace.



- table is the name of a table.

### Synopsis Legend

- Angle brackets (< >) mean not literal, a variable
- Italics mean optional
- The pipe (|) symbol means OR or AND/OR
- Ellipsis (...) means repeatable
- Orange ( and ) means not literal, indicates scope

### Description

The `nodetool cfhistograms` command provides statistics about a table, including read/write latency, partition size, column count, and number of SSTables. The report covers all operations since the last time you ran `nodetool cfhistograms` in this session. The use of the `metrics-core` library in Cassandra 2.1 makes the output more informative and easier to understand.

### Example

For example, to get statistics about the `libout` table in the `libdata` keyspace on Linux, use this command:

```
$ install_location/bin/nodetool cfhistograms libdata libout
```

Output is:

```
libdata/libout histograms
Percentile  SSTables      Write Latency      Read Latency      Partition Size
      Cell Count
              (micros)          (micros)          (bytes)
50%          0.00          39.50          36.00          1597
              42
75%          0.00          49.00          55.00          1597
              42
95%          0.00          95.00          82.00          8239
              258
98%          0.00          126.84         110.42         17084
              446
99%          0.00          155.13         123.71         24601
              770
Min          0.00          3.00          3.00          1110
              36
Max          0.00          50772.00       314.00         126934
              3973
```

The output shows the percentile rank of read and write latency values, the partition size, and the cell count for the table.

### nodetool cfstats

Provides statistics about tables.

Provides statistics about tables.

### Synopsis

```
$ nodetool <options> cfstats -i -- (<keyspace>.<table> ... ) -H
```

- options are:

## Cassandra tools

- ( -h | --host ) <host name> | <ip address>
- ( -p | --port ) <port number>
- ( -pw | --password ) <password >
- ( -u | --username ) <user name>
- ( -pwf <passwordFilePath | --password-file <passwordFilePath> )
- -- separates an option from an argument that could be mistaken for a option.
- i ignores the following tables, providing only information about other Cassandra tables
- keyspace.table is one or more keyspace and table names in dot notation.
- H converts bytes to a human readable form: kilobytes (KB), megabytes (MB), gigabytes (GB), or terabytes (TB). (Cassandra 2.1.1)

### Synopsis Legend

- Angle brackets (< >) mean not literal, a variable
- Italics mean optional
- The pipe (|) symbol means OR or AND/OR
- Ellipsis (...) means repeatable
- Orange ( and ) means not literal, indicates scope

### Description

The `nodetool cfstats` command provides statistics about one or more tables. You use dot notation to specify one or more keyspace and table names. If you do not specify a keyspace and table, Cassandra provides statistics about all tables. If you use the `-i` option, Cassandra provides statistics about all tables except the given ones. The use of the metrics-core library in Cassandra 2.1 makes the output more informative and easier to understand.

This table describes the `nodetool cfstats` output.

**Table 11: nodetool cfstats output**

Name of statistic	Example value	Brief description	Related information
Keyspace	libdata	Name of the <b>keyspace</b>	<b>Keyspace and table</b>
Read count	11207	Number of requests to read tables in the libdata keyspace since startup	
Read latency	0.047... ms	Latency reading the tables in the libdata keyspace	<b>OpsCenter alert metrics</b>
Write count	17598	Number of requests to update tables in the libdata keyspace since startup	Same as above

Name of statistic	Example value	Brief description	Related information
Write latency	0.053. . . ms	Latency writing tables in the libdata keyspace	Same as above
Pending tasks	0	Tasks in the queue for reads, writes, and cluster operations of tables in the keyspace	<a href="#">OpsCenter pending task metrics</a>
Table	libout	Name of the Cassandra <a href="#">table</a>	
SSTable count	3	Number of <a href="#">SSTables</a> containing data from the table	<a href="#">How to use the SSTable counts metric and OpsCenter alert metrics</a>
Space used (live), bytes:	9592399	Space used by the table (depends on operating system)	<a href="#">Advanced system alert metrics</a>
Space used (total), bytes:	9592399	Same as above	Same as above
Space used by snapshots (total), bytes:	0	Same occupied by backup data	
SSTable compression ratio	0.367. . .	Fraction of data-representation size resulting from compression	Types of <a href="#">compression</a> option)
Memtable cell count	1022550	Number of cells (storage engine rows x columns) of data in the <a href="#">memtable</a>	<a href="#">Cassandra memtable structure in memory</a>
Memtable data size, bytes	32028148	Size of the memtable data	Same as above
Memtable switch count	3	Number of times a full memtable	<a href="#">How memtables are measured</a> article

Name of statistic	Example value	Brief description	Related information
		was swapped for an empty one (Increases each time the memtable for a table is flushed to disk)	
Local read count	11207	Number of local read requests for the libout table since startup	<a href="#">OpsCenter alert documentation</a>
Local read latency	0.048 ms	Round trip time in milliseconds to complete a request to read the libout table	<a href="#">Factors that affect read latency</a>
Local write count	17598	Number of local requests to update the libout the table since startup	<a href="#">OpsCenter alert documentation</a>
Local write latency	0.054 ms	Round trip time in milliseconds to complete an update to the libout table	<a href="#">Factors that affect write latency</a>
Pending tasks	0	Number of read, write, and cluster operations that are pending	<a href="#">OpsCenter pending task metrics documentation</a>
Bloom filter false positives	0	Number of false positives, which occur when the bloom filter	<a href="#">Tuning bloom filters</a>

Name of statistic	Example value	Brief description	Related information
		said the row existed, but it actually did not exist in absolute numbers	
Bloom filter false ratio	0.00000	Fraction of all bloom filter checks resulting in a false positive	Same as above
Bloom filter space used, bytes	11688	Size of bytes of the bloom filter data	Same as above
Compacted partition minimum bytes	1110	Lower size limit for the partition being compacted in memory	Used to calculate what the approximate row cache size should be. Multiply the reported row cache size, which is the number of rows in the cache, by the compacted row mean size for every table and sum them.
Compacted partition maximum bytes	126934	Upper size limit for compacted table rows.	Configurable in the cassandra.yaml <code>in_memory_compaction_limit_in_mb</code>
Compacted partition mean bytes	2730	The average size of compacted table rows	
Average live cells per slice (last five minutes)	0.0	Average of cells scanned by single key queries during the last five minutes	
Average tombstones per slice (last five minutes)	0.0	Average of tombstones scanned by single key queries during the last five minutes	

### Examples

This example shows an excerpt of the output of the command after flushing a table of library data to disk.

```

$ nodetool cfstats libdata.libout
Keyspace: libdata
Read Count: 11207
Read Latency: 0.047931114482020164 ms.
Write Count: 17598
Write Latency: 0.053502954881236506 ms.
Pending Flushes: 0
  Table: libout
  SSTable count: 3
  Space used (live), bytes: 9088955
  Space used (total), bytes: 9088955
  Space used by snapshots (total), bytes: 0
  SSTable Compression Ratio: 0.36751363892150946
  Memtable cell count: 0
  Memtable data size, bytes: 0
  Memtable switch count: 3
  Local read count: 11207
  Local read latency: 0.048 ms
  Local write count: 17598
  Local write latency: 0.054 ms
  Pending flushes: 0
  Bloom filter false positives: 0
  Bloom filter false ratio: 0.00000
  Bloom filter space used, bytes: 11688
  Compacted partition minimum bytes: 1110
  Compacted partition maximum bytes: 126934
  Compacted partition mean bytes: 2730
  Average live cells per slice (last five minutes): 0.0
  Average tombstones per slice (last five minutes): 0.0

```

### Using the human-readable option

Using the human-readable `-H` option provides output in easier-to-read units than bytes. For example:

```

$ nodetool cfstats demodb.nhanes -H
Keyspace: demodb
Read Count: 0
Read Latency: NaN ms.
Write Count: 20050
Write Latency: 0.08548014962593516 ms.
Pending Flushes: 0
  Table: nhanes
  SSTable count: 1
  Space used (live): 13.75 MB
  Space used (total): 13.75 MB
  Space used by snapshots (total): 0 bytes
  SSTable Compression Ratio: 0.3064650643762481
  Memtable cell count: 0
  Memtable data size: 0 bytes
  Memtable switch count: 1
  Local read count: 0
  Local read latency: NaN ms
  Local write count: 20050
  Local write latency: 0.085 ms
  Pending flushes: 0
  Bloom filter false positives: 0
  Bloom filter false ratio: 0.00000
  Bloom filter space used: 23.73 KB
  Compacted partition minimum bytes: 1.87 KB
  Compacted partition maximum bytes: 2.69 KB
  Compacted partition mean bytes: 2.26 KB
  Average live cells per slice (last five minutes): 0.0
  Maximum live cells per slice (last five minutes): 0.0
  Average tombstones per slice (last five minutes): 0.0

```

```
Maximum tombstones per slice (last five minutes): 0.0
```

The location of the `cassandra.yaml` file depends on the type of installation:

Package installations	<code>/etc/cassandra/cassandra.yaml</code>
Tarball installations	<code>install_location/resources/cassandra/conf/cassandra.yaml</code>

## nodetool cleanup

Cleans up keyspaces and partition keys no longer belonging to a node.

Cleans up keyspaces and partition keys no longer belonging to a node.

### Synopsis

```
$ nodetool <options> cleanup -- <keyspace> (<table> ...)
```

- options are:
  - ( `-h` | `--host` ) `<host name>` | `<ip address>`
  - ( `-p` | `--port` ) `<port number>`
  - ( `-pw` | `--password` ) `<password >`
  - ( `-u` | `--username` ) `<user name>`
  - ( `-pwf` `<passwordFilePath>` | `--password-file` `<passwordFilePath>` )
- `--` separates an option from an argument that could be mistaken for an option.
- `keyspace` is a keyspace name.
- `table` is one or more table names, separated by a space.

### Synopsis Legend

- Angle brackets (`<>`) mean not literal, a variable
- Italics mean optional
- The pipe (`|`) symbol means OR or AND/OR
- Ellipsis (`...`) means repeatable
- Orange ( `and` ) means not literal, indicates scope

### Description

Use this command to remove unwanted data after adding a new node to the cluster. Cassandra does not automatically remove data from nodes that lose part of their partition range to a newly added node. Run `nodetool cleanup` on the source node and on neighboring nodes that shared the same subrange after the new node is up and running. Failure to run this command after adding a node causes Cassandra to include the old data to rebalance the load on that node. Running the `nodetool cleanup` command causes a temporary increase in disk space usage proportional to the size of your largest SSTable. Disk I/O occurs when running this command.

Running this command affects nodes that use a counter column in a table. Cassandra assigns a new counter ID to the node.

Optionally, this command takes a list of table names. If you do not specify a keyspace, this command cleans all keyspaces no longer belonging to a node.

### nodetool clearsnapshot

Removes one or more snapshots.

Removes one or more snapshots.

#### Synopsis

```
$ nodetool <options> clearsnapshot -t <snapshot> -- ( <keyspace> ... )
```

- options are:
  - ( -h | --host ) <host name> | <ip address>
  - ( -p | --port ) <port number>
  - ( -pw | --password ) <password >
  - ( -u | --username ) <user name>
  - ( -pwf <passwordFilePath | --password-file <passwordFilePath> )
- -t means the following file contains the snapshot.
- snapshot is the name of the snapshot.
- -- separates an option from an argument that could be mistaken for a option.
- keyspace is one or more keyspace names, separated by a space.

#### Synopsis Legend

- Angle brackets (< >) mean not literal, a variable
- Italics mean optional
- The pipe (|) symbol means OR or AND/OR
- Ellipsis (...) means repeatable
- Orange ( and ) means not literal, indicates scope

#### Description

Deletes snapshots in one or more keyspaces. To remove all snapshots, omit the snapshot name.

**Caution:** Removing all snapshots or all specific keyspace snapshots also removes OpsCenter backups.

### nodetool compact

Forces a major compaction on one or more tables.

Forces a major compaction on one or more tables.

#### Synopsis

```
$ nodetool <options> compact <keyspace> ( <table> ... )
```

- options are:
  - ( -h | --host ) <host name> | <ip address>
  - ( -p | --port ) <port number>
  - ( -pw | --password ) <password >
  - ( -u | --username ) <user name>
  - ( -pwf <passwordFilePath | --password-file <passwordFilePath> )
- -- separates an option and argument that could be mistaken for a option.
- keyspace is the name of a keyspace.
- table is one or more table names, separated by a space.



### Synopsis Legend

- Angle brackets (< >) mean not literal, a variable
- Italics mean optional
- The pipe (|) symbol means OR or AND/OR
- Ellipsis (...) means repeatable
- Orange ( and ) means not literal, indicates scope

### Description

This command starts the **compaction process** on tables that use the SizeTieredCompactionStrategy and DateTieredCompactionStrategy. You can specify a keyspace for compaction. If you do not specify a keyspace, the nodetool command uses the current keyspace. You can specify one or more tables for compaction. If you do not specify any tables, compaction of all tables in the keyspace occurs. This is called a major compaction. If you do specify one or more tables, compaction of the specified tables occurs. This is called a minor compaction. A major compaction combines each of the pools of repaired and unrepaired SSTables into one repaired and one unrepaired SSTable. During compaction, there is a temporary spike in disk space usage and disk I/O because the old and new SSTables co-exist. A major compaction can cause considerable disk I/O.

### nodetool compactionhistory

Provides the history of compaction operations.

Provides the history of compaction operations.

### Synopsis

```
$ nodetool <options> compactionhistory
```

options are:

- ( -h | --host ) <host name> | <ip address>
- ( -p | --port ) <port number>
- ( -pw | --password ) <password >
- ( -u | --username ) <user name>
- ( -pwf <passwordFilePath | --password-file <passwordFilePath> )

### Synopsis Legend

- Angle brackets (< >) mean not literal, a variable
- Italics mean optional
- The pipe (|) symbol means OR or AND/OR
- Ellipsis (...) means repeatable
- Orange ( and ) means not literal, indicates scope

### Example

The actual output of compaction history is seven columns wide. The first three columns show the id, keyspace name, and table name of the compacted SSTable.

```
$ nodetool compactionhistory
```

```
Compaction History:
id                keyspace_name
columnfamily_name
d06f7080-07a5-11e4-9b36-abc3a0ec9088  system
schema_columnfamilies
```

d198ae40-07a5-11e4-9b36-abc3a0ec9088	libdata	users		
0381bc30-07b0-11e4-9b36-abc3a0ec9088	Keyspace1	Standard1		
74eb69b0-0621-11e4-9b36-abc3a0ec9088	system	local		
e35dd980-07ae-11e4-9b36-abc3a0ec9088	system			
compactions_in_progress				
8d5cf160-07ae-11e4-9b36-abc3a0ec9088	system			
compactions_in_progress				
ba376020-07af-11e4-9b36-abc3a0ec9088	Keyspace1	Standard1		
d18cc760-07a5-11e4-9b36-abc3a0ec9088	libdata	libout		
64009bf0-07a4-11e4-9b36-abc3a0ec9088	libdata	libout		
d04700f0-07a5-11e4-9b36-abc3a0ec9088	system	sstable_activity		
c2a97370-07a9-11e4-9b36-abc3a0ec9088	libdata	users		
cb928a80-07ae-11e4-9b36-abc3a0ec9088	Keyspace1	Standard1		
cd8d1540-079e-11e4-9b36-abc3a0ec9088	system	schema_columns		
62ced2b0-07a4-11e4-9b36-abc3a0ec9088	system	schema_keyspaces		
d19cccf0-07a5-11e4-9b36-abc3a0ec9088	system			
compactions_in_progress				
640bbf80-07a4-11e4-9b36-abc3a0ec9088	libdata	users		
6cd54e60-07ae-11e4-9b36-abc3a0ec9088	Keyspace1	Standard1		
c29241f0-07a9-11e4-9b36-abc3a0ec9088	libdata	libout		
c2a30ad0-07a9-11e4-9b36-abc3a0ec9088	system			
compactions_in_progress				
e3a6d920-079d-11e4-9b36-abc3a0ec9088	system	schema_keyspaces		
62c55cd0-07a4-11e4-9b36-abc3a0ec9088	system			
schema_columnfamilies				
62b07540-07a4-11e4-9b36-abc3a0ec9088	system	schema_columns		
cdd038c0-079e-11e4-9b36-abc3a0ec9088	system	schema_keyspaces		
b797af00-07af-11e4-9b36-abc3a0ec9088	Keyspace1	Standard1		
8c918b10-07ae-11e4-9b36-abc3a0ec9088	Keyspace1	Standard1		
377d73f0-07ae-11e4-9b36-abc3a0ec9088	system			
compactions_in_progress				
62b9c410-07a4-11e4-9b36-abc3a0ec9088	system	local		
d0566a40-07a5-11e4-9b36-abc3a0ec9088	system	schema_columns		
ba637930-07af-11e4-9b36-abc3a0ec9088	system			
compactions_in_progress				
cdbcl480-079e-11e4-9b36-abc3a0ec9088	system			
schema_columnfamilies				
e3456f80-07ae-11e4-9b36-abc3a0ec9088	Keyspace1	Standard1		
d086f020-07a5-11e4-9b36-abc3a0ec9088	system	schema_keyspaces		
d06118a0-07a5-11e4-9b36-abc3a0ec9088	system	local		
cdaafd80-079e-11e4-9b36-abc3a0ec9088	system	local		
640fde30-07a4-11e4-9b36-abc3a0ec9088	system			
compactions_in_progress				
37638350-07ae-11e4-9b36-abc3a0ec9088	Keyspace1	Standard1		

The four columns to the right of the table name show the timestamp, size of the SSTable before and after compaction, and the number of partitions merged. The notation means {tables:rows}. For example: {1:3, 3:1} means 3 rows were taken from one SSTable (1:3) and 1 row taken from 3 SSTables (3:1) to make the one SSTable in that compaction operation.

. . . compacted_at	bytes_in	bytes_out	rows_merged
. . . 1404936947592	8096	7211	{1:3, 3:1}
. . . 1404936949540	144	144	{1:1}
. . . 1404941328243	1305838191	1305838191	{1:4647111}
. . . 1404770149323	5864	5701	{4:1}
. . . 1404940844824	573	148	{1:1, 2:2}
. . . 1404940700534	576	155	{1:1, 2:2}
. . . 1404941205282	766331398	766331398	{1:2727158}
. . . 1404936949462	8901649	8901649	{1:9315}
. . . 1404936336175	8900821	8900821	{1:9315}
. . . 1404936947327	223	108	{1:3, 2:1}
. . . 1404938642471	144	144	{1:1}

. . . 1404940804904	383020422	383020422	{1:1363062}
. . . 1404933936276	4889	4177	{1:4}
. . . 1404936334171	441	281	{1:3, 2:1}
. . . 1404936949567	379	79	{2:2}
. . . 1404936336248	144	144	{1:1}
. . . 1404940645958	307520780	307520780	{1:1094380}
. . . 1404938642319	8901649	8901649	{1:9315}
. . . 1404938642429	416	165	{1:3, 2:1}
. . . 1404933543858	692	281	{1:3, 2:1}
. . . 1404936334109	7760	7186	{1:3, 2:1}
. . . 1404936333972	4860	4724	{1:2, 2:1}
. . . 1404933936715	441	281	{1:3, 2:1}
. . . 1404941200880	1269180898	1003196133	{1:2623528,
2:946565}			
. . . 1404940699201	297639696	297639696	{1:1059216}
. . . 1404940556463	592	148	{1:2, 2:2}
. . . 1404936334033	5760	5680	{2:1}
. . . 1404936947428	8413	5316	{1:2, 3:1}
. . . 1404941205571	429	42	{2:2}
. . . 1404933936584	7994	6789	{1:4}
. . . 1404940844664	306699417	306699417	{1:1091457}
. . . 1404936947746	601	281	{1:3, 3:1}
. . . 1404936947498	5840	5680	{3:1}
. . . 1404933936472	5861	5680	{3:1}
. . . 1404936336275	378	80	{2:2}
. . . 1404940556293	302170540	281000000	{1:924660, 2:75340}

## nodetool compactionstats

Provide statistics about a compaction.

Provide statistics about a compaction.

### Synopsis

```
$ nodetool <options> compactionstats -H
```

- options are:
  - ( -h | --host ) <host name> | <ip address>
  - ( -p | --port ) <port number>
  - ( -pw | --password ) <password >
  - ( -u | --username ) <user name>
  - ( -pwf <passwordFilePath | --password-file <passwordFilePath> )
- separates an option and argument that could be mistaken for a option.
- data center is the name of an arbitrarily chosen data center from which to select sources for streaming.
- H converts bytes to a human readable form: kilobytes (KB), megabytes (MB), gigabytes (GB), or terabytes (TB). (Cassandra 2.1.1)

### Synopsis Legend

- Angle brackets (< >) mean not literal, a variable
- Italics mean optional
- The pipe (|) symbol means OR or AND/OR
- Ellipsis (...) means repeatable
- Orange ( and ) means not literal, indicates scope

### Description

The total column shows the total number of uncompressed bytes of SSTables being compacted. The system log lists the names of the SSTables compacted.

### Example

```
$ bin/nodetool compactionstats
```

```
pending tasks: 5
      compaction type      keyspace      table      completed
      total      unit progress
      302170540      bytes      93.43%      Keyspace1      Standard1      282310680
      307520780      bytes      19.01%      Keyspace1      Standard1      58457931
Active compaction remaining time : 0h00m16s
```

### nodetool decommission

Deactivates a node by streaming its data to another node.

Deactivates a node by streaming its data to another node.

### Synopsis

```
$ nodetool <options> decommission
```

options are:

- ( -h | --host ) <host name> | <ip address>
- ( -p | --port ) <port number>
- ( -pw | --password ) <password >
- ( -u | --username ) <user name>
- ( -pwf <passwordFilePath | --password-file <passwordFilePath> )

### Synopsis Legend

- Angle brackets (< >) mean not literal, a variable
- Italics mean optional
- The pipe (|) symbol means OR or AND/OR
- Ellipsis (...) means repeatable
- Orange ( and ) means not literal, indicates scope

### Description

Causes a live node to decommission itself, streaming its data to the next node on the ring. Use [netstats](http://wiki.apache.org/cassandra/NodeProbe#Decommission) to monitor the progress, as described on <http://wiki.apache.org/cassandra/NodeProbe#Decommission> and [http://wiki.apache.org/cassandra/Operations#Removing\\_nodes\\_entirely](http://wiki.apache.org/cassandra/Operations#Removing_nodes_entirely).

### nodetool describecluster

Provide the name, snitch, partitioner and schema version of a cluster

Provide the name, snitch, partitioner and schema version of a cluster

### Synopsis

```
$ nodetool <options> describecluster -- <data center>
```

- options are:
  - ( -h | --host ) <host name> | <ip address>
  - ( -p | --port ) <port number>
  - ( -pw | --password ) <password >
  - ( -u | --username ) <user name>
  - ( -pwf <passwordFilePath | --password-file <passwordFilePath> )
- separates an option and argument that could be mistaken for a option.
- data center is the name of an arbitrarily chosen data center from which to select sources for streaming.

### Synopsis Legend

- Angle brackets (< >) mean not literal, a variable
- Italics mean optional
- The pipe (|) symbol means OR or AND/OR
- Ellipsis (...) means repeatable
- Orange ( and ) means not literal, indicates scope

### Description

Describe cluster is typically used to validate the schema after upgrading. If a schema disagreement occurs, check for and [resolve schema disagreements](#).

### Example

```
$ bin/nodetool describecluster
```

```
Cluster Information:
Name: Test Cluster
Snitch: org.apache.cassandra.locator.DynamicEndpointSnitch
Partitioner: org.apache.cassandra.dht.Murmur3Partitioner
Schema versions:
  65e78f0e-e81e-30d8-a631-a65dff93bf82: [127.0.0.1]
```

If a schema disagreement occurs, the last line of the output includes information about unreachable nodes.

```
$ bin/nodetool describecluster
```

```
Cluster Information:
Name: Production Cluster
  Snitch: org.apache.cassandra.locator.DynamicEndpointSnitch
  Partitioner: org.apache.cassandra.dht.Murmur3Partitioner
  Schema versions:
    UNREACHABLE: 1176b7ac-8993-395d-85fd-41b89ef49fbb:
    [10.202.205.203]
```

### nodetool describering

Provides the partition ranges of a keyspace.

Provides the partition ranges of a keyspace.

### Synopsis

```
$ nodetool <options> describering -- <keyspace>
```

- options are:

- ( -h | --host ) <host name> | <ip address>
- ( -p | --port ) <port number>
- ( -pw | --password ) <password >
- ( -u | --username ) <user name>
- ( -pwf <passwordFilePath | --password-file <passwordFilePath> )
- -- separates an option from an argument that could be mistaken for a option.
- keyspace is a keyspace name.

### Synopsis Legend

- Angle brackets (< >) mean not literal, a variable
- Italics mean optional
- The pipe (|) symbol means OR or AND/OR
- Ellipsis (...) means repeatable
- Orange ( and ) means not literal, indicates scope

### Example

This example shows the sample output of the command on a three-node cluster.

```
$ nodetool describering demo_keyspace
```

```
Schema Version:1b04bd14-0324-3fc8-8bcb-9256d1e15f82
TokenRange:
  TokenRange(start_token:3074457345618258602,
    end_token:-9223372036854775808,
      endpoints:[127.0.0.1, 127.0.0.2, 127.0.0.3],
      rpc_endpoints:[127.0.0.1, 127.0.0.2, 127.0.0.3],
      endpoint_details:[EndpointDetails(host:127.0.0.1,
datacenter:datacenter1, rack:rack1),
  EndpointDetails(host:127.0.0.2, datacenter:datacenter1,
rack:rack1),
  EndpointDetails(host:127.0.0.3, datacenter:datacenter1,
rack:rack1)])
  TokenRange(start_token:-3074457345618258603,
    end_token:3074457345618258602,
      endpoints:[127.0.0.3, 127.0.0.1, 127.0.0.2],
      rpc_endpoints:[127.0.0.3, 127.0.0.1, 127.0.0.2],
      endpoint_details:[EndpointDetails(host:127.0.0.3,
datacenter:datacenter1, rack:rack1),
  EndpointDetails(host:127.0.0.1, datacenter:datacenter1,
rack:rack1),
  EndpointDetails(host:127.0.0.2, datacenter:datacenter1,
rack:rack1)])
  TokenRange(start_token:-9223372036854775808,
    end_token:-3074457345618258603,
      endpoints:[127.0.0.2, 127.0.0.3, 127.0.0.1],
      rpc_endpoints:[127.0.0.2, 127.0.0.3, 127.0.0.1],
      endpoint_details:[EndpointDetails(host:127.0.0.2,
datacenter:datacenter1, rack:rack1),
  EndpointDetails(host:127.0.0.3, datacenter:datacenter1,
rack:rack1),
  EndpointDetails(host:127.0.0.1, datacenter:datacenter1,
rack:rack1)])
```

If a schema disagreement occurs, the last line of the output includes information about unreachable nodes.

```
$ bin/nodetool describecluster
```

```
Cluster Information:
Name: Production Cluster
Snitch: org.apache.cassandra.locator.DynamicEndpointSnitch
Partitioner: org.apache.cassandra.dht.Murmur3Partitioner
Schema versions:
    UNREACHABLE: 1176b7ac-8993-395d-85fd-41b89ef49fbb:
[10.202.205.203]
```

## nodetool disableautocompaction

Disables autocompaction for a keyspace and one or more tables.

Disables autocompaction for a keyspace and one or more tables.

### Synopsis

```
$ nodetool <options> disableautocompaction -- <keyspace> ( <table> ... )
```

- options are:
  - ( -h | --host ) <host name> | <ip address>
  - ( -p | --port ) <port number>
  - ( -pw | --password ) <password >
  - ( -u | --username ) <user name>
  - ( -pwf <passwordFilePath | --password-file <passwordFilePath> )
- -- separates an option and argument that could be mistaken for a option.
- keyspace is the name of a keyspace.
- table is one or more table names, separated by a space.

### Synopsis Legend

- Angle brackets (< >) mean not literal, a variable
- Italics mean optional
- The pipe (|) symbol means OR or AND/OR
- Ellipsis (...) means repeatable
- Orange ( and ) means not literal, indicates scope

### Description

The keyspace can be followed by one or more tables.

## nodetool disablebackup

Disables incremental backup.

Disables incremental backup.

### Synopsis

```
$ nodetool <options> disablebackup
```

options are:

- ( -h | --host ) <host name> | <ip address>
- ( -p | --port ) <port number>
- ( -pw | --password ) <password >
- ( -u | --username ) <user name>

## Cassandra tools

- ( -pwf <passwordFilePath | --password-file <passwordFilePath> )

### Synopsis Legend

- Angle brackets (< >) mean not literal, a variable
- Italics mean optional
- The pipe (|) symbol means OR or AND/OR
- Ellipsis (...) means repeatable
- Orange ( and ) means not literal, indicates scope

## nodetool disablebinary

Disables the native transport.

Disables the native transport.

### Synopsis

```
$ nodetool <options> disablebinary
```

options are:

- ( -h | --host ) <host name> | <ip address>
- ( -p | --port ) <port number>
- ( -pw | --password ) <password >
- ( -u | --username ) <user name>
- ( -pwf <passwordFilePath | --password-file <passwordFilePath> )

### Synopsis Legend

- Angle brackets (< >) mean not literal, a variable
- Italics mean optional
- The pipe (|) symbol means OR or AND/OR
- Ellipsis (...) means repeatable
- Orange ( and ) means not literal, indicates scope

### Description

Disables the binary protocol, also known as the native transport.

## nodetool disablegossip

Disables the gossip protocol.

Disables the gossip protocol.

### Synopsis

```
$ nodetool <options> disablegossip
```

options are:

- ( -h | --host ) <host name> | <ip address>
- ( -p | --port ) <port number>
- ( -pw | --password ) <password >
- ( -u | --username ) <user name>
- ( -pwf <passwordFilePath | --password-file <passwordFilePath> )



**Synopsis Legend**

- Angle brackets (< >) mean not literal, a variable
- Italics mean optional
- The pipe (|) symbol means OR or AND/OR
- Ellipsis (...) means repeatable
- Orange ( and ) means not literal, indicates scope

**Description**

This command effectively marks the node as being down.

**nodetool disablehandoff**

Disables storing of future hints on the current node.

Disables storing of future hints on the current node.

**Synopsis**

```
$ nodetool <options> disablehandoff
```

options are:

- ( -h | --host ) <host name> | <ip address>
- ( -p | --port ) <port number>
- ( -pw | --password ) <password >
- ( -u | --username ) <user name>
- ( -pwf <passwordFilePath | --password-file <passwordFilePath> )

**Synopsis Legend**

- Angle brackets (< >) mean not literal, a variable
- Italics mean optional
- The pipe (|) symbol means OR or AND/OR
- Ellipsis (...) means repeatable
- Orange ( and ) means not literal, indicates scope

**nodetool disablethrift**

Disables the Thrift server.

Disables the Thrift server.

**Synopsis**

```
$ nodetool <options> disablethrift
```

options are:

- ( -h | --host ) <host name> | <ip address>
- ( -p | --port ) <port number>
- ( -pw | --password ) <password >
- ( -u | --username ) <user name>
- ( -pwf <passwordFilePath | --password-file <passwordFilePath> )

**Synopsis Legend**

- Angle brackets (< >) mean not literal, a variable

## Cassandra tools

- Italics mean optional
- The pipe (|) symbol means OR or AND/OR
- Ellipsis (...) means repeatable
- Orange ( and ) means not literal, indicates scope

### Description

`nodetool disablethrift` will disable thrift on a node preventing the node from acting as a coordinator. The node can still be a replica for a different coordinator and data read at consistency level ONE could be stale. To cause a node to ignore read requests from other coordinators, `nodetool disablegossip` would also need to be run. However, if both commands are run, the node will not perform repairs, and the node will continue to store stale data. If the goal is to repair the node, set the read operations to a consistency level of QUORUM or higher while you run repair. An alternative approach is to delete the node's data and restart the Cassandra process.

### Examples

```
$ nodetool -u cassandra -pw cassandra disablethrift 192.168.100.1
```

```
C:\ nodetool -u cassandra -pw cassandra disablethrift 192.168.100.1
```

## nodetool drain

Drains the node.

Drains the node.

### Synopsis

```
$ nodetool <options> drain
```

options are:

- ( -h | --host ) <host name> | <ip address>
- ( -p | --port ) <port number>
- ( -pw | --password ) <password >
- ( -u | --username ) <user name>
- ( -pwf <passwordFilePath> | --password-file <passwordFilePath> )

### Synopsis Legend

- Angle brackets (< >) mean not literal, a variable
- Italics mean optional
- The pipe (|) symbol means OR or AND/OR
- Ellipsis (...) means repeatable
- Orange ( and ) means not literal, indicates scope

### Description

Flushes all memtables from the node to SSTables on disk. Cassandra stops listening for connections from the client and other nodes. You need to restart Cassandra after running `nodetool drain`. You typically use this command before upgrading a node to a new version of Cassandra. To simply flush memtables to disk, use `nodetool flush`.

## nodetool enableautocompaction

Enables autocompaction for a keyspace and one or more tables.

Enables autocompaction for a keyspace and one or more tables.

### Synopsis

```
$ nodetool <options> enableautocompaction -- <keyspace> ( <table> ... )
```

- options are:
  - ( -h | --host ) <host name> | <ip address>
  - ( -p | --port ) <port number>
  - ( -pw | --password ) <password >
  - ( -u | --username ) <user name>
  - ( -pwf <passwordFilePath | --password-file <passwordFilePath> )
- separates an option and argument that could be mistaken for a option.
- keyspace is the name of a keyspace.
- table is the name of one or more keyspace, separated by a space.

### Synopsis Legend

- Angle brackets (< >) mean not literal, a variable
- Italics mean optional
- The pipe (|) symbol means OR or AND/OR
- Ellipsis (...) means repeatable
- Orange ( and ) means not literal, indicates scope

### Description

The keyspace can be followed by one or more tables. Enables compaction for the named keyspace or the current keyspace, and one or more named tables, or all tables.

## nodetool enablebackup

Enables incremental backup.

Enables incremental backup.

### Synopsis

```
$ nodetool <options> enablebackup
```

options are:

- ( -h | --host ) <host name> | <ip address>
- ( -p | --port ) <port number>
- ( -pw | --password ) <password >
- ( -u | --username ) <user name>
- ( -pwf <passwordFilePath | --password-file <passwordFilePath> )

### Synopsis Legend

- Angle brackets (< >) mean not literal, a variable
- Italics mean optional
- The pipe (|) symbol means OR or AND/OR
- Ellipsis (...) means repeatable
- Orange ( and ) means not literal, indicates scope

### nodetool enablebinary

Re-enables native transport.

Re-enables native transport.

#### Synopsis

```
$ nodetool <options> enablebinary
```

options are:

- ( -h | --host ) <host name> | <ip address>
- ( -p | --port ) <port number>
- ( -pw | --password ) <password >
- ( -u | --username ) <user name>
- ( -pwf <passwordFilePath | --password-file <passwordFilePath> )

#### Synopsis Legend

- Angle brackets (< >) mean not literal, a variable
- Italics mean optional
- The pipe (|) symbol means OR or AND/OR
- Ellipsis (...) means repeatable
- Orange ( and ) means not literal, indicates scope

#### Description

Re-enables the binary protocol, also known as native transport.

### nodetool enablegossip

Re-enables gossip.

Re-enables gossip.

#### Synopsis

```
$ nodetool <options> enablegossip
```

options are:

- ( -h | --host ) <host name> | <ip address>
- ( -p | --port ) <port number>
- ( -pw | --password ) <password >
- ( -u | --username ) <user name>
- ( -pwf <passwordFilePath | --password-file <passwordFilePath> )

#### Synopsis Legend

- Angle brackets (< >) mean not literal, a variable
- Italics mean optional
- The pipe (|) symbol means OR or AND/OR
- Ellipsis (...) means repeatable
- Orange ( and ) means not literal, indicates scope

## nodetool enablehandoff

Re-enables the storing of future hints on the current node.

Re-enables the storing of future hints on the current node.

### Synopsis

```
$ nodetool <options> enablehandoff
```

- options are:
  - ( -h | --host ) <host name> | <ip address>
  - ( -p | --port ) <port number>
  - ( -pw | --password ) <password >
  - ( -u | --username ) <user name>
  - ( -pwf <passwordFilePath | --password-file <passwordFilePath> )
- separates an option and argument that could be mistaken for a option.
- <dc-name>,<dc-name> means enable hinted handoff only for these data centers

### Synopsis Legend

- Angle brackets (< >) mean not literal, a variable
- Italics mean optional
- The pipe (|) symbol means OR or AND/OR
- Ellipsis (...) means repeatable
- Orange ( and ) means not literal, indicates scope

## nodetool enablethrift

Re-enables the Thrift server.

Re-enables the Thrift server.

### Synopsis

```
$ nodetool <options> enablethrift
```

options are:

- ( -h | --host ) <host name> | <ip address>
- ( -p | --port ) <port number>
- ( -pw | --password ) <password >
- ( -u | --username ) <user name>
- ( -pwf <passwordFilePath | --password-file <passwordFilePath> )

### Synopsis Legend

- Angle brackets (< >) mean not literal, a variable
- Italics mean optional
- The pipe (|) symbol means OR or AND/OR
- Ellipsis (...) means repeatable
- Orange ( and ) means not literal, indicates scope

## nodetool flush

Flushes one or more tables from the memtable.

Flushes one or more tables from the memtable.

### Synopsis

```
$ nodetool <options> flush -- <keyspace> ( <table> ... )
```

- options are:
  - ( -h | --host ) <host name> | <ip address>
  - ( -p | --port ) <port number>
  - ( -pw | --password ) <password >
  - ( -u | --username ) <user name>
  - ( -pwf <passwordFilePath | --password-file <passwordFilePath> )
- -- separates an option and argument that could be mistaken for a option.
- keyspace is the name of a keyspace.
- table is the name of one or more tables, separated by a space.

### Synopsis Legend

- Angle brackets (< >) mean not literal, a variable
- Italics mean optional
- The pipe (|) symbol means OR or AND/OR
- Ellipsis (...) means repeatable
- Orange ( and ) means not literal, indicates scope

### Description

You can specify a keyspace followed by one or more tables that you want to flush from the memtable to SSTables on disk.

## nodetool getcompactionthreshold

Provides the minimum and maximum compaction thresholds in megabytes for a table.

Provides the minimum and maximum compaction thresholds in megabytes for a table.

### Synopsis

```
$ nodetool <options> getcompactionthreshold -- <keyspace> <table>
```

- options are:
  - ( -h | --host ) <host name> | <ip address>
  - ( -p | --port ) <port number>
  - ( -pw | --password ) <password >
  - ( -u | --username ) <user name>
  - ( -pwf <passwordFilePath | --password-file <passwordFilePath> )
- -- separates an option and argument that could be mistaken for a option.
- keyspace is the name of a keyspace.
- table is the name of a table.

### Synopsis Legend

- Angle brackets (< >) mean not literal, a variable
- Italics mean optional
- The pipe (|) symbol means OR or AND/OR
- Ellipsis (...) means repeatable
- Orange ( and ) means not literal, indicates scope

## nodetool getendpoints

Provides the IP addresses or names of replicas that own the partition key.

Provides the IP addresses or names of replicas that own the partition key.

### Synopsis

```
$ nodetool <options> getendpoints -- <keyspace> <table> key
```

- options are:
  - ( -h | --host ) <host name> | <ip address>
  - ( -p | --port ) <port number>
  - ( -pw | --password ) <password >
  - ( -u | --username ) <user name>
  - ( -pwf <passwordFilePath | --password-file <passwordFilePath> )
- separates an option and argument that could be mistaken for a option.
- keyspace is a keyspace name.
- table is a table name.
- key is the partition key of the end points you want to get.

### Synopsis Legend

- Angle brackets (< >) mean not literal, a variable
- Italics mean optional
- The pipe (|) symbol means OR or AND/OR
- Ellipsis (...) means repeatable
- Orange ( and ) means not literal, indicates scope

### Example

For example, which nodes own partition key\_1, key\_2, and key\_3?

**Note:** The partitioner returns a token for the key. Cassandra will return an endpoint whether or not data exists on the identified node for that token.

```
$ bin/nodetool -h 127.0.0.1 -p 7100 getendpoints myks mytable key_1
```

```
127.0.0.2
```

```
$ bin/nodetool -h 127.0.0.1 -p 7100 getendpoints myks mytable key_2
```

```
127.0.0.2
```

```
$ bin/nodetool -h 127.0.0.1 -p 7100 getendpoints myks mytable key_3
```

```
127.0.0.1
```

## nodetool getlogginglevels

Get the runtime logging levels.

Get the runtime logging levels.

### Synopsis

```
$ nodetool <options> getlogginglevels
```

options are:

- ( -h | --host ) <host name> | <ip address>
- ( -p | --port ) <port number>
- ( -pw | --password ) <password>
- ( -u | --username ) <user name>
- ( -pwf <passwordFilePath | --password-file <passwordFilePath> )

### Synopsis Legend

- Angle brackets (< >) mean not literal, a variable
- Italics mean optional
- The pipe (|) symbol means OR or AND/OR
- Ellipsis (...) means repeatable
- Orange ( and ) means not literal, indicates scope

### nodetool getsstables

Provides the SSTables that own the partition key.

Provides the SSTables that own the partition key.

### Synopsis

```
$ nodetool <options> getsstables -- <keyspace> <table> key
```

- options are:
  - ( -h | --host ) <host name> | <ip address>
  - ( -p | --port ) <port number>
  - ( -pw | --password ) <password >
  - ( -u | --username ) <user name>
  - ( -pwf <passwordFilePath | --password-file <passwordFilePath> )
- -- separates an option and argument that could be mistaken for a option.
- keyspace is a keyspace name.
- table is a table name.
- key is the partition key of the SSTables.

### Synopsis Legend

- Angle brackets (< >) mean not literal, a variable
- Italics mean optional
- The pipe (|) symbol means OR or AND/OR
- Ellipsis (...) means repeatable
- Orange ( and ) means not literal, indicates scope

### nodetool getstreamthroughput

Provides the megabytes per second throughput limit for streaming in the system.

Provides the megabytes per second throughput limit for streaming in the system.



## Synopsis

```
$ nodetool <options> getstreamthroughput
```

options are:

- ( -h | --host ) <host name> | <ip address>
- ( -p | --port ) <port number>
- ( -pw | --password ) <password >
- ( -u | --username ) <user name>
- ( -pwf <passwordFilePath | --password-file <passwordFilePath> )

## Synopsis Legend

- Angle brackets (< >) mean not literal, a variable
- Italics mean optional
- The pipe (|) symbol means OR or AND/OR
- Ellipsis (...) means repeatable
- Orange ( and ) means not literal, indicates scope

## nodetool gossipinfo

Provides the gossip information for the cluster.

Provides the gossip information for the cluster.

## Synopsis

```
$ nodetool <options> gossipinfo
```

options are:

- ( -h | --host ) <host name> | <ip address>
- ( -p | --port ) <port number>
- ( -pw | --password ) <password >
- ( -u | --username ) <user name>
- ( -pwf <passwordFilePath | --password-file <passwordFilePath> )

## Synopsis Legend

- Angle brackets (< >) mean not literal, a variable
- Italics mean optional
- The pipe (|) symbol means OR or AND/OR
- Ellipsis (...) means repeatable
- Orange ( and ) means not literal, indicates scope

## nodetool help

Provides nodetool command help.

Provides nodetool command help.

## Synopsis

```
$ nodetool help <command>
```

## Synopsis Legend

- Angle brackets (< >) mean not literal, a variable

## Cassandra tools

- Italics mean optional
- The pipe (|) symbol means OR or AND/OR
- Ellipsis (...) means repeatable
- Orange ( and ) means not literal, indicates scope

### Description

Using this command without the The help command provides a synopsis and brief description of each nodetool command.

### Examples

Using nodetool help lists all commands and usage information. For example, `nodetool help netstats` provides the following information.

```
NAME
    nodetool netstats - Print network information on provided host
    (connecting node by default)

SYNOPSIS
    nodetool [(-h <host> | --host <host>)] [(-p <port> | --port <port>)]
    [(-pw <password> | --password <password>)]
    [(-u <username> | --username <username>)] netstats

OPTIONS
    -h <host>, --host <host>
        Node hostname or ip address

    -p <port>, --port <port>
        Remote jmx agent port number

    -pw <password>, --password <password>
        Remote jmx agent password

    -u <username>, --username <username>
        Remote jmx agent username
```

### nodetool info

Provides node information, such as load and uptime.

Provides node information, such as load and uptime.

### Synopsis

```
$ nodetool <options> info ( -T | --tokens )
```

- options are:
  - ( -h | --host ) <host name> | <ip address>
  - ( -p | --port ) <port number>
  - ( -pw | --password ) <password >
  - ( -u | --username ) <user name>
  - ( -pwf <passwordFilePath | --password-file <passwordFilePath> )
- -T or --tokens means provide all token information.

### Synopsis Legend

- Angle brackets (< >) mean not literal, a variable

- Italics mean optional
- The pipe (|) symbol means OR or AND/OR
- Ellipsis (...) means repeatable
- Orange ( and ) means not literal, indicates scope

### Description

Provides node information including the token and on disk storage (load) information, times started (generation), uptime in seconds, and heap memory usage.

### nodetool invalidatekeycache

Resets the global key cache parameter to the default, which saves all keys.

Resets the global key cache parameter to the default, which saves all keys.

### Synopsis

```
$ nodetool <options> invalidatekeycache
```

options are:

- ( -h | --host ) <host name> | <ip address>
- ( -p | --port ) <port number>
- ( -pw | --password ) <password >
- ( -u | --username ) <user name>
- ( -pwf <passwordFilePath | --password-file <passwordFilePath> )

### Synopsis Legend

- Angle brackets (< >) mean not literal, a variable
- Italics mean optional
- The pipe (|) symbol means OR or AND/OR
- Ellipsis (...) means repeatable
- Orange ( and ) means not literal, indicates scope

### Description

By default the `key_cache_keys_to_save` is disabled in the `cassandra.yaml`. This command resets the parameter to the default.

The location of the `cassandra.yaml` file depends on the type of installation:

Package installations	<code>/etc/cassandra/cassandra.yaml</code>
Tarball installations	<code>install_location/resources/cassandra/conf/cassandra.yaml</code>

### nodetool invalidaterowcache

Resets the global key cache parameter, `row_cache_keys_to_save`, to the default (not set), which saves all keys.

Resets the global key cache parameter, `row_cache_keys_to_save`, to the default (not set), which saves all keys.

### Synopsis

```
$ nodetool <options> invalidaterowcache
```

## Cassandra tools

options are:

- ( -h | --host ) <host name> | <ip address>
- ( -p | --port ) <port number>
- ( -pw | --password ) <password >
- ( -u | --username ) <user name>
- ( -pwf <passwordFilePath | --password-file <passwordFilePath> )

### Synopsis Legend

- Angle brackets (< >) mean not literal, a variable
- Italics mean optional
- The pipe (|) symbol means OR or AND/OR
- Ellipsis (...) means repeatable
- Orange ( and ) means not literal, indicates scope

## nodetool join

Causes the node to join the ring.

Causes the node to join the ring.

### Synopsis

```
$ nodetool <options> join
```

options are:

- ( -h | --host ) <host name> | <ip address>
- ( -p | --port ) <port number>
- ( -pw | --password ) <password >
- ( -u | --username ) <user name>
- ( -pwf <passwordFilePath | --password-file <passwordFilePath> )

### Synopsis Legend

- Angle brackets (< >) mean not literal, a variable
- Italics mean optional
- The pipe (|) symbol means OR or AND/OR
- Ellipsis (...) means repeatable
- Orange ( and ) means not literal, indicates scope

### Description

Causes the node to join the ring, assuming the node was initially *not* started in the ring using the - `Djoin_ring=false` cassandra utility option. The joining node should be properly configured with the desired options for seed list, initial token, and auto-bootstrapping.

## nodetool listsnapshots

Lists snapshot names, size on disk, and true size.

Lists snapshot names, size on disk, and true size.

### Synopsis

```
nodetool <options> listsnapshots
```

options are:

- ( -h | --host ) <host name> | <ip address>
- ( -p | --port ) <port number>
- ( -pw | --password ) <password >
- ( -u | --username ) <user name>
- ( -pwf <passwordFilePath | --password-file <passwordFilePath> )

### Synopsis Legend

- Angle brackets (< >) mean not literal, a variable
- Italics mean optional
- The pipe (|) symbol means OR or AND/OR
- Ellipsis (...) means repeatable
- Orange ( and ) means not literal, indicates scope

### Description

Available in Cassandra 2.1 and later.

### Example

```
Snapshot Details:
Snapshot Name  Keyspace  Column Family  True Size  Size on Disk
1387304478196  Keyspace1 Standard1      0 bytes   308.66 MB
1387304417755  Keyspace1 Standard1      0 bytes   107.21 MB
1387305820866  Keyspace1 Standard2      0 bytes    41.69 MB
                Keyspace1 Standard1      0 bytes   308.66 MB
```

## nodetool move

Moves the node on the token ring to a new token.

Moves the node on the token ring to a new token.

### Synopsis

```
$ nodetool <options> move -- <new token>
```

- options are:
  - ( -h | --host ) <host name> | <ip address>
  - ( -p | --port ) <port number>
  - ( -pw | --password ) <password >
  - ( -u | --username ) <user name>
  - ( -pwf <passwordFilePath | --password-file <passwordFilePath> )
- -- separates an option and argument that could be mistaken for a option.
- new token is a number in the range  $-2^{63}$  to  $+2^{63}-1$ .

### Synopsis Legend

- Angle brackets (< >) mean not literal, a variable
- Italics mean optional
- The pipe (|) symbol means OR or AND/OR
- Ellipsis (...) means repeatable

## Cassandra tools

- Orange ( and ) means not literal, indicates scope

### Description

Escape negative tokens using \\. For example: move \\-123 . This command essentially combines decommission and bootstrapoperations.

## nodetool netstats

Provides network information about the host.

Provides network information about the host.

### Synopsis

```
$ nodetool <options> netstats -H
```

- options are:
  - ( -h | --host ) <host name> | <ip address>
  - ( -p | --port ) <port number>
  - ( -pw | --password ) <password >
  - ( -u | --username ) <user name>
  - ( -pwf <passwordFilePath | --password-file <passwordFilePath> )
- H converts bytes to a human readable form: kilobytes (KB), megabytes (MB), gigabytes (GB), or terabytes (TB). (Cassandra 2.1.1)

### Synopsis Legend

- Angle brackets (< >) mean not literal, a variable
- Italics mean optional
- The pipe (|) symbol means OR or AND/OR
- Ellipsis (...) means repeatable
- Orange ( and ) means not literal, indicates scope

### Description

The default host is the connected host if the user does not include a host name or IP address in the command. The output includes the following information:

- JVM settings
- Mode
- Read repair statistics
- Attempted

The number of successfully completed **read repair operations**

- Mismatch (blocking)

The number of read repair operations since server restart that blocked a query.

- Mismatch (background)

The number of read repair operations since server restart performed in the background.

- Pool name

Information about **client read and write requests** by thread pool.

- Active, pending, and completed number of commands and responses

## Example

Get the network information for a node 10.171.147.128:

```
$ nodetool -h 10.171.147.128 netstats
```

The output is:

```

Mode: NORMAL
Not sending any streams.
Read Repair Statistics:
Attempted: 0
Mismatch (Blocking): 0
Mismatch (Background): 0
Pool Name           Active   Pending   Completed
Commands            n/a     0         1156
Responses           n/a     0         2750

```

## nodetool pausehandoff

Pauses the hints delivery process

Pauses the hints delivery process

### Synopsis

```
$ nodetool <options> pausehandoff
```

options are:

- ( -h | --host ) <host name> | <ip address>
- ( -p | --port ) <port number>
- ( -pw | --password ) <password >
- ( -u | --username ) <user name>
- ( -pwf <passwordFilePath> | --password-file <passwordFilePath> )

### Synopsis Legend

- Angle brackets (< >) mean not literal, a variable
- Italics mean optional
- The pipe (|) symbol means OR or AND/OR
- Ellipsis (...) means repeatable
- Orange ( and ) means not literal, indicates scope

## nodetool proxyhistograms

Provides a histogram of network statistics.

Provides a histogram of network statistics.

### Synopsis

```
$ nodetool <options> proxyhistograms
```

options are:

- ( -h | --host ) <host name> | <ip address>
- ( -p | --port ) <port number>
- ( -pw | --password ) <password >
- ( -u | --username ) <user name>

## Cassandra tools

- ( `-pwf <passwordFilePath | --password-file <passwordFilePath>` )

### Synopsis Legend

- Angle brackets (< >) mean not literal, a variable
- Italics mean optional
- The pipe (|) symbol means OR or AND/OR
- Ellipsis (...) means repeatable
- Orange ( and ) means not literal, indicates scope

### Description

The output of this command shows the full request latency recorded by the coordinator. The output includes the percentile rank of read and write latency values for inter-node communication. Typically, you use the command to see if requests encounter a slow node.

### Examples

This example shows the output from `nodetool proxyhistograms` after running 4,500 insert statements and 45,000 select statements on a three `ccm` node-cluster on a local computer.

```
$ nodetool proxyhistograms
```

```
proxy histograms
Percentile      Read Latency      Write Latency      Range Latency
                (micros)          (micros)           (micros)
50%             1502.50           375.00             446.00
75%             1714.75           420.00             498.00
95%             31210.25          507.00             800.20
98%             36365.00          577.36             948.40
99%             36365.00          740.60             1024.39
Min             616.00            230.00             311.00
Max             36365.00          55726.00           59247.00
```

## nodetool rangekeysample

Provides the sampled keys held across all keyspaces.

Provides the sampled keys held across all keyspaces.

### Synopsis

```
$ nodetool <options> rangekeysample
```

options are:

- ( `-h | --host` ) `<host name>` | `<ip address>`
- ( `-p | --port` ) `<port number>`
- ( `-pw | --password` ) `<password >`
- ( `-u | --username` ) `<user name>`
- ( `-pwf <passwordFilePath | --password-file <passwordFilePath>` )

### Synopsis Legend

- Angle brackets (< >) mean not literal, a variable
- Italics mean optional
- The pipe (|) symbol means OR or AND/OR
- Ellipsis (...) means repeatable
- Orange ( and ) means not literal, indicates scope



## nodetool rebuild

Rebuilds data by streaming from other nodes.

Rebuilds data by streaming from other nodes.

### Synopsis

```
$ nodetool <options> rebuild -- <src-dc-name>
```

- options are:
  - ( -h | --host ) <host name> | <ip address>
  - ( -p | --port ) <port number>
  - ( -pw | --password ) <password >
  - ( -u | --username ) <user name>
  - ( -pwf <passwordFilePath | --password-file <passwordFilePath> )
- separates an option and argument that could be mistaken for a option.
- src-dc-name is the name of the data center from which to select sources for streaming. You can pick any data center.

### Synopsis Legend

- Angle brackets (< >) mean not literal, a variable
- Italics mean optional
- The pipe (|) symbol means OR or AND/OR
- Ellipsis (...) means repeatable
- Orange ( and ) means not literal, indicates scope

### Description

This command operates on multiple nodes in a cluster. Similar to bootstrap. Rebuild (like bootstrap) only streams data from a single source replica per range. Use this command to [bring up a new data center](#) in an existing cluster.

## nodetool rebuild\_index

Performs a full rebuild of the index for a table

Performs a full rebuild of the index for a table

### Synopsis

```
$ nodetool <options> rebuild_index -- ( <keyspace>.<table>.<indexName> ... )
```

- options are:
  - ( -h | --host ) <host name> | <ip address>
  - ( -p | --port ) <port number>
  - ( -pw | --password ) <password >
  - ( -u | --username ) <user name>
  - ( -pwf <passwordFilePath | --password-file <passwordFilePath> )
- separates an option and argument that could be mistaken for a option.
- keyspace is a keyspace name.
- table is a table name.
- indexName is an optional list of index names separated by a space.

## Cassandra tools

The keyspace and table name followed by a list of index names. For example: `Standard3.IdxName`  
`Standard3.IdxName1`

### Synopsis Legend

- Angle brackets (< >) mean not literal, a variable
- Italics mean optional
- The pipe (|) symbol means OR or AND/OR
- Ellipsis (...) means repeatable
- Orange ( and ) means not literal, indicates scope

### Description

Fully rebuilds one or more indexes for a table.

## nodetool refresh

Loads newly placed SSTables onto the system without a restart.

Loads newly placed SSTables onto the system without a restart.

### Synopsis

```
$ nodetool <options> refresh -- <keyspace> <table>
```

- options are:
  - ( -h | --host ) <host name> | <ip address>
  - ( -p | --port ) <port number>
  - ( -pw | --password ) <password >
  - ( -u | --username ) <user name>
  - ( -pwf <passwordFilePath | --password-file <passwordFilePath> )
- -- separates an option and argument that could be mistaken for a option.
- keyspace is a keyspace name.
- table is a table name.

### Synopsis Legend

- Angle brackets (< >) mean not literal, a variable
- Italics mean optional
- The pipe (|) symbol means OR or AND/OR
- Ellipsis (...) means repeatable
- Orange ( and ) means not literal, indicates scope

## nodetool reloadtriggers

Reloads trigger classes.

Reloads trigger classes.

### Synopsis

```
$ nodetool <options> reloadtriggers
```

options are:

- ( -h | --host ) <host name> | <ip address>
- ( -p | --port ) <port number>

- ( `-pw | --password` ) `<password >`
- ( `-u | --username` ) `<user name>`
- ( `-pwf <passwordFilePath | --password-file <passwordFilePath>` )

### Synopsis Legend

- Angle brackets (`< >`) mean not literal, a variable
- Italics mean optional
- The pipe (`|`) symbol means OR or AND/OR
- Ellipsis (`...`) means repeatable
- Orange ( `and` ) means not literal, indicates scope

### Description

Available in Cassandra 2.1 and later.

## nodetool removenode

Provides the status of current node removal, forces completion of pending removal, or removes the identified node.

Provides the status of current node removal, forces completion of pending removal, or removes the identified node.

### Synopsis

```
$ nodetool <options> removenode -- <status> | <force> | <ID>
```

- options are:
  - ( `-h | --host` ) `<host name> | <ip address>`
  - ( `-p | --port` ) `<port number>`
  - ( `-pw | --password` ) `<password >`
  - ( `-u | --username` ) `<user name>`
  - ( `-pwf <passwordFilePath | --password-file <passwordFilePath>` )
- `--` separates an option and argument that could be mistaken for a option.
- `status` provides status information.
- `force` forces completion of the pending removal.
- `ID` is the host ID, in UUID format.

### Synopsis Legend

- Angle brackets (`< >`) mean not literal, a variable
- Italics mean optional
- The pipe (`|`) symbol means OR or AND/OR
- Ellipsis (`...`) means repeatable
- Orange ( `and` ) means not literal, indicates scope

### Description

This command removes a node, shows the status of a removal operation, or forces the completion of a pending removal. When the node is down and `nodetool decommission` cannot be used, use `nodetool removenode`. Run this command only on nodes that are down. If the cluster does not use `vnodes`, before running the `nodetool removenode` command, [adjust the tokens](#).

## Examples

Determine the UUID of the node to remove by running `nodetool status`. Use the UUID of the node that is down to remove the node.

```
$ nodetool status
```

```
Datacenter: DC1
=====
Status=Up/Down
|/ State=Normal/Leaving/Joining/Moving
--  Address          Load           Tokens   Owns (effective)  Host ID
                                     Rack
UN  192.168.2.101    112.82 KB     256      31.7%             420129fc-0d84-42b0-
be41-ef7dd3a8ad06  RAC1
DN  192.168.2.103    91.11 KB      256      33.9%             d0844a21-3698-4883-
ab66-9e2fd5150edd  RAC1
UN  192.168.2.102    124.42 KB     256      32.6%             8d5ed9f4-7764-4dbd-
bad8-43fddce94b7c  RAC1
```

```
$ nodetool removemode d0844a21-3698-4883-ab66-9e2fd5150edd
```

View the status of the operation to remove the node:

```
$ nodetool removemode status
```

```
RemovalStatus: No token removals in process.
```

Confirm that the node has been removed.

```
$ nodetool removemode status
```

```
Datacenter: DC1
=====
Status=Up/Down
|/ State=Normal/Leaving/Joining/Moving
--  Address          Load           Tokens   Owns (effective)  Host ID
                                     Rack
UN  192.168.2.101    112.82 KB     256      37.7%             420129fc-0d84-42b0-
be41-ef7dd3a8ad06  RAC1
UN  192.168.2.102    124.42 KB     256      38.3%             8d5ed9f4-7764-4dbd-
bad8-43fddce94b7c  RAC1
```

## nodetool repair

Repairs one or more tables.

Repairs one or more tables.

## Synopsis

```
$ nodetool <options> repair
( -dc <dc_name> ) | ( --in-dc <dc_name> )
( -et <end_token> ) | ( --end-token <end_token> )
( -hosts <host_name host_name . . . > ) | ( --in-hosts <host_name
host_name . . . > )
( -inc | --incremental )
( -local | --in-local-dc )
( -par | --parallel )
( -pr | --partitioner-range )
```

```
( -st <start_token> ) | ( --start-token <start_token> )
-- <keyspace> ( <table> ... )
```

- options are:
  - ( -h | --host ) <host name> | <ip address>
  - ( -p | --port ) <port number>
  - ( -pw | --password ) <password >
  - ( -u | --username ) <user name>
  - ( -pwf <passwordFilePath | --password-file <passwordFilePath> )
- dc, or --in-dc, followed by dc\_name, or means restrict repair to nodes in the named data center, which must be the local data center.
- dcpair, or --dc-parallel, means repair data centers in parallel.
- et, or --end-token, followed by the UUID of a token means stop repairing a range of nodes after repairing this token. Use -hosts to specify neighbor nodes.
- hosts <host\_name host\_name . . . >, or --in-hosts <host\_name host\_name . . . >, means repair specific hosts.
- inc, or --incremental means do an incremental repair.
- local, or --in-local-dc, means repair nodes in the same data center only.
- par, or --parallel, means do a parallel repair.
- pr, or --partitioner-range, means repair only the first range returned by the partitioner.
- st, or --start-token, followed by the UUID of a token means start repairing a range of nodes at this token.
- separates an option and argument that could be mistaken for a option.
- keyspace is the keyspace name. The default is all.
- table is one or more table names, separated by a space. The default is all.

### Synopsis Legend

- Angle brackets (< >) mean not literal, a variable
- Italics mean optional
- The pipe (|) symbol means OR or AND/OR
- Ellipsis (...) means repeatable
- Orange ( and ) means not literal, indicates scope

### Description

Performing an anti-entropy node repair on a **regular basis** is important, especially when frequently deleting data. The nodetool repair command repairs one or more nodes in a cluster, and includes an option to restrict repair to a set of nodes. Anti-entropy node repair performs the following tasks:

- Ensures that all data on a replica is consistent.
- Repairs inconsistencies on a node that has been down.

By default, Cassandra 2.1 does a full, **sequential repair**.

### Using options

You can use options to do these other types of repair:

- Incremental
- Parallel

Use the -hosts option to list the good nodes to use for repairing the bad nodes. Use -h to name the bad nodes.

Use the -inc option for an **incremental repair**. An incremental repair eliminates the need for constant Merkle tree construction by persisting already repaired data and calculating only the Merkle trees for SSTables

that have not been repaired. The repair process is likely more performant than the other types of repair even as datasets grow, assuming you run repairs frequently. Before doing an incremental repair for the first time, perform [migration steps](#) first if necessary.

Use the `-par` option for a parallel repair. Unlike [sequential repair](#), parallel repair constructs the Merkle tables for all nodes at the same time. Therefore, no snapshots are required (or generated). Use a parallel repair to complete the repair quickly or when you have operational downtime that allows the resources to be completely consumed during the repair.

Performing [partitioner range repairs](#) by using the `-pr` option is generally not recommended.

### Example

All `nodetool repair` arguments are optional. The following examples show the following types of repair:

- An incremental, parallel repair of all keyspaces on the current node
- A partitioner range repair of the bad partition on current node using the good partitions on 10.2.2.20 or 10.2.2.21
- A start-point-to-end-point repair of all nodes between two nodes on the ring

```
$ nodetool repair -par -inc
$ nodetool repair -pr -hosts 10.2.2.20 10.2.2.21
$ nodetool -st a9fa31c7-f3c0-44d1-b8e7-a26228867840c -et f5bb146c-
db51-475ca44f-9facf2f1ad6e
```

To restrict the repair to the local data center, use the `-dc` option followed by the name of the data center. Issue the command from a node in the data center you want to repair. Issuing the command from a data center other than the named one returns an error. Do not use `-pr` with this option to repair only a local data center.

```
$ nodetool repair -dc DC1
```

```
[2014-07-24 21:59:55,326] Nothing to repair for keyspace 'system'
[2014-07-24 21:59:55,617] Starting repair command #2, repairing 490 ranges
    for keyspace system_traces (seq=true, full=true)
[2014-07-24 22:23:14,299] Repair session 323b9490-137e-11e4-88e3-
c972e09793ca
    for range (820981369067266915,822627736366088177] finished
[2014-07-24 22:23:14,320] Repair session 38496a61-137e-11e4-88e3-
c972e09793ca
    for range (2506042417712465541,2515941262699962473] finished
. . .
```

An inspection of the `system.log` shows repair taking place only on IP addresses in DC1.

```
. . .
INFO [AntiEntropyStage:1] 2014-07-24 22:23:10,708 RepairSession.java:171
- [repair #16499ef0-1381-11e4-88e3-c972e09793ca] Received merkle tree
  for sessions from /192.168.2.101
INFO [RepairJobTask:1] 2014-07-24 22:23:10,740 RepairJob.java:145
- [repair #16499ef0-1381-11e4-88e3-c972e09793ca] requesting merkle trees
  for events (to [/192.168.2.103, /192.168.2.101])
. . .
```

### nodetool resetlocalschema

Reset the node's local schema and resynchronizes.

Reset the node's local schema and resynchronizes.

## Synopsis

```
$ nodetool <options> resetlocalschema
```

options are:

- ( -h | --host ) <host name> | <ip address>
- ( -p | --port ) <port number>
- ( -pw | --password ) <password>
- ( -u | --username ) <user name>
- ( -pwf <passwordFilePath | --password-file <passwordFilePath> )

## Synopsis Legend

- Angle brackets (< >) mean not literal, a variable
- Italics mean optional
- The pipe (|) symbol means OR or AND/OR
- Ellipsis (...) means repeatable
- Orange ( and ) means not literal, indicates scope

## Description

Normally, this command is used to rectify schema disagreements on different nodes. It can be useful if table schema changes have generated too many tombstones, on the order of 100,000s.

`nodetool resetlocalschema` drops the schema information of the local node and resynchronizes the schema from another node. To drop the schema, the tool truncates all the system schema tables. The node will temporarily lose metadata about the tables on the node, but will rewrite the information from another node. If the node is experiencing problems with too many tombstones, the truncation of the tables will eliminate the tombstones.

This command is useful when you have one node that is out of sync with the cluster. The system schema tables must have another node from which to fetch the tables. It is not useful when all or many of your nodes are in an incorrect state. If there is only one node in the cluster (replication factor of 1) – it does not perform the operation, because another node from which to fetch the tables does not exist. Run the command on the node experiencing difficulty.

## nodetool resumehandoff

Resume hints delivery process.

Resume hints delivery process.

## Synopsis

```
$ nodetool <options> resumehandoff
```

options are:

- ( -h | --host ) <host name> | <ip address>
- ( -p | --port ) <port number>
- ( -pw | --password ) <password>
- ( -u | --username ) <user name>
- ( -pwf <passwordFilePath | --password-file <passwordFilePath> )

## Synopsis Legend

- Angle brackets (< >) mean not literal, a variable
- Italics mean optional

## Cassandra tools

- The pipe (|) symbol means OR or AND/OR
- Ellipsis (...) means repeatable
- Orange ( and ) means not literal, indicates scope

### nodetool ring

Provides node status and information about the ring.

Provides node status and information about the ring.

#### Synopsis

```
$ nodetool <options> ring ( -r | --resolve-ip ) -- <keyspace>
```

- options are:
  - ( -h | --host ) <host name> | <ip address>
  - ( -p | --port ) <port number>
  - ( -pw | --password ) <password >
  - ( -u | --username ) <user name>
  - ( -pwf <passwordFilePath | --password-file <passwordFilePath> )
- -r, or --resolve-ip, means to provide node names instead of IP addresses.
- -- separates an option and argument that could be mistaken for a option.
- keyspace is a keyspace name.

#### Synopsis Legend

- Angle brackets (< >) mean not literal, a variable
- Italics mean optional
- The pipe (|) symbol means OR or AND/OR
- Ellipsis (...) means repeatable
- Orange ( and ) means not literal, indicates scope

#### Description

Displays node status and information about the ring as determined by the node being queried. This information can give you an idea of the load balance and if any nodes are down. If your cluster is not properly configured, different nodes may show a different ring. Check that the node appears the same way in the ring. If you use virtual nodes (vnodes), use `nodetool status` for succinct output.

- Address  
The node's URL.
- DC (data center)  
The data center containing the node.
- Rack  
The rack or, in the case of Amazon EC2, the availability zone of the node.
- Status - Up or Down  
Indicates whether the node is functioning or not.
- State - N (normal), L (leaving), J (joining), M (moving)  
The state of the node in relation to the cluster.
- Load - updates every 90 seconds  
The amount of file system data under the cassandra data directory after excluding all content in the snapshots subdirectories. Because all SSTable data files are included, any data that is not cleaned up, such as TTL-expired cell or tombstoned data) is counted.



- Token

The end of the token range up to and including the value listed. For an explanation of token ranges, see [Data Distribution in the Ring](#).

- Owns

The percentage of the data owned by the node per data center times the replication factor. For example, a node can own 33% of the ring, but show 100% if the replication factor is 3.

- Host ID

The network ID of the node.

## nodetool scrub

Rebuild SSTables for one or more Cassandra tables.

Rebuild SSTables for one or more Cassandra tables.

### Synopsis

```
$ nodetool <options> scrub <keyspace> -- ( -ns | --no-snapshot ) ( -s | --skip-corrupted ) ( <table> ... )
```

- options are:
  - ( -h | --host ) <host name> | <ip address>
  - ( -p | --port ) <port number>
  - ( -pw | --password ) <password >
  - ( -u | --username ) <user name>
  - ( -pwf <passwordFilePath | --password-file <passwordFilePath> )
- -- separates an option and argument that could be mistaken for a option.
- keyspace is the name of a keyspace.
- -ns, or --no-snapshot, triggers a snapshot of the scrubbed table first assuming snapshots are not disabled (the default).
- -s, or --skip-corrupted skips corrupted partitions even when scrubbing counter tables. (default false)
- table is one or more table names, separated by a space.

### Synopsis Legend

- Angle brackets (< >) mean not literal, a variable
- Italics mean optional
- The pipe (|) symbol means OR or AND/OR
- Ellipsis (...) means repeatable
- Orange ( and ) means not literal, indicates scope

### Description

Rebuilds SSTables on a node for the named tables and snapshots data files before rebuilding as a safety measure. If possible use [upgradesstables](#). While scrub rebuilds SSTables, it also discards data that it deems broken and creates a snapshot, which you have to remove manually. If the -ns option is specified, snapshot creation is disabled. If scrub can't validate the column value against the column definition's data type, it logs the partition key and skips to the next partition. Skipping corrupted partitions in tables having counter columns results in under-counting. By default the scrub operation stops if you attempt to skip such a partition. To force the scrub to skip the partition and continue scrubbing, re-run `nodetool scrub` using the `--skip-corrupted` option.

## nodetool setcachecapacity

Set global key and row cache capacities in megabytes.

Set global key and row cache capacities in megabytes.

### Synopsis

```
$ nodetool <options> setcachecapacity -- <key-cache-capacity> <row-cache-capacity>
```

- options are:
  - ( -h | --host ) <host name> | <ip address>
  - ( -p | --port ) <port number>
  - ( -pw | --password ) <password >
  - ( -u | --username ) <user name>
  - ( -pwf <passwordFilePath | --password-file <passwordFilePath> )
- separates an option and argument that could be mistaken for a option.
- key-cache-capacity is the maximum size in MB of the key cache in memory.
- row-cache-capacity corresponds to the maximum size in MB of the row cache in memory.
- counter-cache-capacity corresponds to the maximum size in MB of the counter cache in memory.

### Synopsis Legend

- Angle brackets (< >) mean not literal, a variable
- Italics mean optional
- The pipe (|) symbol means OR or AND/OR
- Ellipsis (...) means repeatable
- Orange ( and ) means not literal, indicates scope

### Description

The key-cache-capacity argument corresponds to the `key_cache_size_in_mb` parameter in the `cassandra.yaml`. Each key cache hit saves one seek and each row cache hit saves a minimum of two seeks. Devoting some memory to the key cache is usually a good tradeoff considering the positive effect on the response time. The default value is empty, which means a minimum of five percent of the heap in MB or 100 MB.

The row-cache-capacity argument corresponds to the `row_cache_size_in_mb` parameter in the `cassandra.yaml`. By default, row caching is zero (disabled).

The counter-cache-capacity argument corresponds to the `counter_cache_size_in_mb` in the `cassandra.yaml`. By default, counter caching is a minimum of 2.5% of Heap or 50MB.

The location of the `cassandra.yaml` file depends on the type of installation:

Package installations	<code>/etc/cassandra/cassandra.yaml</code>
Tarball installations	<code>install_location/resources/cassandra/conf/cassandra.yaml</code>

## nodetool setcachekeystosave

Sets the number of keys saved by each cache for faster post-restart warmup.

Sets the number of keys saved by each cache for faster post-restart warmup.

## Synopsis

```
$ nodetool <options> setcachekeystosave -- <key-cache-keys-to-save> <row-cache-keys-to-save>
```

- options are:
  - ( -h | --host ) <host name> | <ip address>
  - ( -p | --port ) <port number>
  - ( -pw | --password ) <password >
  - ( -u | --username ) <user name>
  - ( -pwf <passwordFilePath | --password-file <passwordFilePath> )
- separates an option and argument that could be mistaken for a option.
- key-cache-keys-to-save is the number of keys from the key cache to save to the saved caches directory.
- row-cache-keys-to-save is the number of keys from the row cache to save to the saved caches directory.

## Synopsis Legend

- Angle brackets (< >) mean not literal, a variable
- Italics mean optional
- The pipe (|) symbol means OR or AND/OR
- Ellipsis (...) means repeatable
- Orange ( and ) means not literal, indicates scope

## Description

This command saves the specified number of key and row caches to the saved caches directory, which you specify in the `cassandra.yaml`. The `key-cache-keys-to-save` argument corresponds to the `key_cache_keys_to_save` in the `cassandra.yaml`, which is disabled by default, meaning all keys will be saved. The `row-cache-keys-to-save` argument corresponds to the `row_cache_keys_to_save` in the `cassandra.yaml`, which is disabled by default.

The location of the `cassandra.yaml` file depends on the type of installation:

Package installations	<code>/etc/cassandra/cassandra.yaml</code>
Tarball installations	<code>install_location/resources/cassandra/conf/cassandra.yaml</code>

## nodetool setcompactionthreshold

Sets minimum and maximum compaction thresholds for a table.

Sets minimum and maximum compaction thresholds for a table.

## Synopsis

```
$ nodetool <options> setcompactionthreshold -- <keyspace> <table> <minthreshold> <maxthreshold>
```

- options are:
  - ( -h | --host ) <host name> | <ip address>
  - ( -p | --port ) <port number>
  - ( -pw | --password ) <password >
  - ( -u | --username ) <user name>

## Cassandra tools

- ( `-pwf <passwordFilePath | --password-file <passwordFilePath>` )
- `--` separates an option and argument that could be mistaken for a option.
- `keyspace` is the name of a keyspace.
- `table` is a table name.
- `minthreshold` sets the minimum number of SSTables to trigger a minor compaction when using `SizeTieredCompactionStrategy` or `DateTieredCompactionStrategy`.
- `maxthreshold` sets the maximum number of SSTables to allow in a minor compaction when using `SizeTieredCompactionStrategy` or `DateTieredCompactionStrategy`.

### Synopsis Legend

- Angle brackets (< >) mean not literal, a variable
- Italics mean optional
- The pipe (|) symbol means OR or AND/OR
- Ellipsis (...) means repeatable
- Orange ( and ) means not literal, indicates scope

### Description

This parameter controls how many SSTables of a similar size must be present before a minor **compaction** is scheduled. The `max_threshold` table property sets an upper bound on the number of SSTables that may be compacted in a single minor compaction, as described in <http://wiki.apache.org/cassandra/MemtableSSTable>.

When using `LeveledCompactionStrategy`, `maxthreshold` sets the `MAX_COMPACTING_L0`, which limits the number of L0 SSTables that are compacted concurrently to avoid wasting memory or running out of memory when compacting highly overlapping SSTables.

## nodetool setcompactionthroughput

Sets the throughput capacity for compaction in the system, or disables throttling.

Sets the throughput capacity for compaction in the system, or disables throttling.

### Synopsis

```
$ nodetool <options> setcompactionthroughput -- <value_in_mb>
```

- options are:
  - ( `-h | --host` ) <host name> | <ip address>
  - ( `-p | --port` ) <port number>
  - ( `-pw | --password` ) <password >
  - ( `-u | --username` ) <user name>
  - ( `-pwf <passwordFilePath | --password-file <passwordFilePath>` )
- `--` separates an option and argument that could be mistaken for a option.
- `value_in_mb` is the throughput capacity in MB per second for compaction.

### Synopsis Legend

- Angle brackets (< >) mean not literal, a variable
- Italics mean optional
- The pipe (|) symbol means OR or AND/OR
- Ellipsis (...) means repeatable
- Orange ( and ) means not literal, indicates scope

**Description**

Set `value_in_mb` to 0 to disable throttling.

**nodetool sethintedhandoffthrottlekb**

Sets hinted handoff throttle in kb/sec per delivery thread. (Cassandra 2.1.1 and later)

Sets hinted handoff throttle in kb/sec per delivery thread. (Cassandra 2.1.1 and later)

**Synopsis**

```
$ nodetool <options> sethintedhandoffthrottlekb <value_in_kb/sec>
```

- options are:
  - ( `-h` | `--host` ) `<host name>` | `<ip address>`
  - ( `-p` | `--port` ) `<port number>`
  - ( `-pw` | `--password` ) `<password >`
  - ( `-u` | `--username` ) `<user name>`
  - ( `-pwf` `<passwordFilePath` | `--password-file` `<passwordFilePath>` )
- `--` separates an option and argument that could be mistaken for a option.
- `value_in_kb/sec` is the throttle time.

**Synopsis Legend**

- Angle brackets (`< >`) mean not literal, a variable
- Italics mean optional
- The pipe (`|`) symbol means OR or AND/OR
- Ellipsis (`...`) means repeatable
- Orange ( `and` ) means not literal, indicates scope

**Description**

When a node detects that a node for which it is holding hints has recovered, it begins sending the hints to that node. This setting specifies the maximum sleep interval per delivery thread in kilobytes per second after delivering each hint. The interval shrinks proportionally to the number of nodes in the cluster. For example, if there are two nodes in the cluster, each delivery thread uses the maximum interval; if there are three nodes, each node throttles to half of the maximum interval, because the two nodes are expected to deliver hints simultaneously.

**Example**

```
nodetool sethintedhandoffthrottlekb 2048
```

**nodetool setlogginglevel**

Set the log level for a service.

Set the log level for a service.

**Synopsis**

```
$ nodetool <options> setlogginglevel -- < class_qualifier > < level >
```

options are:

- ( `-h` | `--host` ) `<host name>` | `<ip address>`
- ( `-p` | `--port` ) `<port number>`

## Cassandra tools

- ( `-pw` | `--password` ) `<password>`
- ( `-u` | `--username` ) `<user name>`
- ( `-pwf` `<passwordFilePath>` | `--password-file` `<passwordFilePath>` )
- `--` separates an option and argument that could be mistaken for a option.
- `class_qualifier` is the logger class qualifier, a fully qualified domain name, such as `org.apache.cassandra.service.StorageProxy`.
- `level` is the logging level, for example `DEBUG`.

### Synopsis Legend

- Angle brackets (`<` `>`) mean not literal, a variable
- Italics mean optional
- The pipe (`|`) symbol means OR or AND/OR
- Ellipsis (`...`) means repeatable
- Orange ( `and` ) means not literal, indicates scope

### Description

You can use this command to set logging levels for services instead of modifying the `logback-text.xml` file. The following values are valid for the logger class qualifier:

- `org.apache.cassandra`
- `org.apache.cassandra.db`
- `org.apache.cassandra.service.StorageProxy`

The possible log levels are:

- `ALL`
- `TRACE`
- `DEBUG`
- `INFO`
- `WARN`
- `ERROR`
- `OFF`

If both class qualifier and level arguments to the command are empty or null, the command resets logging to the initial configuration.

### Example

This command sets the `StorageProxy` service to debug level.

```
$ nodetool setlogginglevel org.apache.cassandra.service.StorageProxy DEBUG
```

## nodetool setstreamthroughput

Sets the throughput capacity in MB for streaming in the system, or disable throttling.

Sets the throughput capacity in MB for streaming in the system, or disable throttling.

### Synopsis

```
$ nodetool <options> setstreamthroughput -- <value_in_mb>
```

- options are:
  - ( `-h` | `--host` ) `<host name>` | `<ip address>`
  - ( `-p` | `--port` ) `<port number>`

- ( -pw | --password ) <password >
- ( -u | --username ) <user name>
- ( -pwf <passwordFilePath | --password-file <passwordFilePath> )
- -- separates an option and argument that could be mistaken for a option.
- value\_in\_mb is the throughput capacity in MB per second for streaming.

### Synopsis Legend

- Angle brackets (< >) mean not literal, a variable
- Italics mean optional
- The pipe (|) symbol means OR or AND/OR
- Ellipsis (...) means repeatable
- Orange ( and ) means not literal, indicates scope

### Description

Set value\_in\_MB to 0 to disable throttling.

## nodetool settraceprobability

Sets the probability for tracing a request.

Sets the probability for tracing a request.

### Synopsis

```
$ nodetool <options> settraceprobability -- <value>
```

- options are:
  - ( -h | --host ) <host name> | <ip address>
  - ( -p | --port ) <port number>
  - ( -pw | --password ) <password >
  - ( -u | --username ) <user name>
  - ( -pwf <passwordFilePath | --password-file <passwordFilePath> )
- -- separates an option and argument that could be mistaken for a option.
- value is a probability between 0 and 1.

### Synopsis Legend

- Angle brackets (< >) mean not literal, a variable
- Italics mean optional
- The pipe (|) symbol means OR or AND/OR
- Ellipsis (...) means repeatable
- Orange ( and ) means not literal, indicates scope

### Description

Probabilistic tracing is useful to determine the cause of intermittent query performance problems by identifying which queries are responsible. This option traces some or all statements sent to a cluster. Tracing a request usually requires at least 10 rows to be inserted.

A probability of 1.0 will trace everything whereas lesser amounts (for example, 0.10) only sample a certain percentage of statements. Care should be taken on large and active systems, as system-wide tracing will have a performance impact. Unless you are under very light load, tracing all requests (probability 1.0) will probably overwhelm your system. Start with a small fraction, for example, 0.001 and increase only if necessary. The trace information is stored in a system\_traces keyspace that holds two tables – sessions and events, which can be easily queried to answer questions, such as what the most time-

consuming query has been since a trace was started. Query the parameters map and thread column in the `system_traces.sessions` and `events` tables for probabilistic tracing information.

### nodetool snapshot

Take a snapshot of one or more keyspaces, or of a table, to backup data.

Take a snapshot of one or more keyspaces, or of a table, to backup data.

#### Synopsis

```
$ nodetool <options> snapshot
( -cf <table> | --column-family <table> )
(-kc <ktlist> | --kc.list <ktlist> | -kt <ktlist> | --kt-list <ktlist>)
( -t <tag> | --tag <tag> )
-- ( <keyspace> ) | ( <keyspace> ... )
```

- options are:
  - ( -h | --host ) <host name> | <ip address>
  - ( -p | --port ) <port number>
  - ( -pw | --password ) <password >
  - ( -u | --username ) <user name>
  - ( -pwf <passwordFilePath | --password-file <passwordFilePath> )
- -cf, or --column-family, followed by the name of the table to be backed up.
- -kc, --kc.list, -kt, or --kt-list, followed by a list of keyspace.table names to be back up, ktlist.
- -t or --tag, followed by the snapshot name.
- -- separates an option and argument that could be mistaken for a option.
- keyspace is a single keyspace name that is required when using the -cf option
- keyspace\_list is one or more optional keyspace names, separated by a space.

#### Synopsis Legend

- Angle brackets (< >) mean not literal, a variable
- Italics mean optional
- The pipe (|) symbol means OR or AND/OR
- Ellipsis (...) means repeatable
- Orange ( and ) means not literal, indicates scope

#### Description

Use this command to [backup and restore](#) using a snapshot. See the examples below for various options.

Cassandra [flushes](#) the node before taking a snapshot, takes the snapshot, and stores the data in the [snapshots directory](#) of each keyspace in the data directory. If you do not specify the name of a snapshot directory using the -t option, Cassandra names the directory using the timestamp of the snapshot, for example 1391460334889. Follow the procedure for [taking a snapshot](#) before upgrading Cassandra. When upgrading, backup all keyspaces. For more information about snapshots, see [Apache documentation](#).

#### Example: All keyspaces

Take a snapshot of all keyspaces on the node. On Linux, in the Cassandra `bin` directory, for example:

```
$ bin/nodetool snapshot
```

The following message appears:

```
Requested creating snapshot(s) for [all keyspaces] with snapshot name
[1391464041163]
```



```
Snapshot directory: 1391464041163
```

Because you did not specify a snapshot name, Cassandra names snapshot directories using the timestamp of the snapshot. If the keyspace contains no data, empty directories are not created.

### Example: Single keyspace snapshot

Assuming you created the keyspace and tables in the [music service example](#), take a snapshot of the music keyspace and name the snapshot 2014.06.24.

```
$ bin/nodetool snapshot -t 2014.06.24 music
```

The following message appears:

```
Requested creating snapshot(s) for [music] with snapshot name [2014.06.24]
Snapshot directory: 2014.06.24
```

Assuming the music keyspace contains two tables, songs and playlists, taking a snapshot of the keyspace creates multiple snapshot directories named 2014.06.24. A number of .db files containing the data are located in these directories. For example, from the installation directory:

```
$ cd data/data/music/playlists-bf8118508cfd11e3972273ded3cb6170/
snapshots/1404936753154
$ ls
```

```
music-playlists-ka-1-CompressionInfo.db  music-playlists-ka-1-Index.db
  music-playlists-ka-1-TOC.txt
music-playlists-ka-1-Data.db              music-playlists-ka-1-Statistics.db
music-playlists-ka-1-Filter.db           music-playlists-ka-1-Summary.db
```

```
$ cd data/data/music/songs-b8e385a08cfd11e3972273ded3cb6170/2014.06.24/
snapshots/1404936753154
```

```
music-songs-ka-1-CompressionInfo.db music-songs-ka-1-Index.db  music-songs-
ka-1-TOC.txt
music-songs-ka-1-Data.db  music-songs-ka-1-Statistics.db
music-songs-ka-1-Filter.db  music-songs-ka-1-Summary.db
```

### Example: Multiple keyspaces snapshot

Assuming you created a keyspace named mykeyspace in addition to the music keyspace, take a snapshot of both keyspaces.

```
$ bin/nodetool snapshot mykeyspace music
```

The following message appears:

```
Requested creating snapshot(s) for [mykeyspace, music] with snapshot name
[1391460334889]
Snapshot directory: 1391460334889
```

### Example: Single table snapshot

Take a snapshot of only the playlists table in the music keyspace.

```
$ bin/nodetool snapshot -cf playlists music
```

```
Requested creating snapshot(s) for [music] with snapshot name  
[1391461910600]  
Snapshot directory: 1391461910600
```

Cassandra creates the snapshot directory named 1391461910600 that contains the backup data of playlists table in data/data/music/playlists-bf8118508cfd11e3972273ded3cb6170/snapshots, for example.

### Example: List of different keyspace.tables snapshot

Take a snapshot of several tables in different keyspaces, such as the playlists table in the music keyspace and the users table in the test keyspace. The keyspace.table list should be comma-delimited with no spaces.

```
$ bin/nodetool snapshot -kt music.playlists,test.users
```

```
Requested creating snapshot(s) for [music.playlists,test.users] with  
snapshot name [1431045288401]  
Snapshot directory: 1431045288401
```

## nodetool status

Provide information about the cluster, such as the state, load, and IDs.

Provide information about the cluster, such as the state, load, and IDs.

### Synopsis

```
$ nodetool <options> status ( -r | --resolve-ip ) -- <keyspace>
```

- options are:
  - ( -h | --host ) <host name> | <ip address>
  - ( -p | --port ) <port number>
  - ( -pw | --password ) <password >
  - ( -u | --username ) <user name>
  - ( -pwf <passwordFilePath | --password-file <passwordFilePath> )
- -r, or --resolve-ip, means to provide node names instead of IP addresses.
- -- separates an option and argument that could be mistaken for a option.
- keyspace is a keyspace name.

### Synopsis Legend

- Angle brackets (< >) mean not literal, a variable
- Italics mean optional
- The pipe (|) symbol means OR or AND/OR
- Ellipsis (...) means repeatable
- Orange ( and ) means not literal, indicates scope

### Description

The status command provides the following information:

- Status - U (up) or D (down)  
Indicates whether the node is functioning or not.

- State - N (normal), L (leaving), J (joining), M (moving)  
The state of the node in relation to the cluster.
- Address  
The node's URL.
- Load - updates every 90 seconds  
The amount of file system data under the cassandra data directory after excluding all content in the snapshots subdirectories. Because all SSTable data files are included, any data that is not cleaned up, such as TTL-expired cell or tombstoned data) is counted.
- Tokens  
The number of tokens set for the node.
- Owns  
The percentage of the data owned by the node per data center times the replication factor. For example, a node can own 33% of the ring, but show 100% if the replication factor is 3.  
**Attention:** If your cluster uses keyspaces having different replication strategies or replication factors, specify a keyspace when you run `nodetool status` to get meaningful ownership information.
- Host ID  
The network ID of the node.
- Rack  
The rack or, in the case of Amazon EC2, the availability zone of the node.

#### Example

This example shows the output from running `nodetool status`.

```
$ nodetool status mykeyspace
Datacenter: datacenter1
=====
Status=Up/Down
|/ State=Normal/Leaving/Joining/Moving
-- Address      Load          Tokens   Owns    Host ID
Rack
UN 127.0.0.1    47.66 KB     1        33.3%   aa1b7c1-6049-4a08-ad3e-3697a0e30e10
rack1
UN 127.0.0.2    47.67 KB     1        33.3%   1848c369-4306-4874-afdf-5c1e95b8732e
rack1
UN 127.0.0.3    47.67 KB     1        33.3%   49578bf1-728f-438d-b1c1-d8dd644b6f7f
rack1
```

## nodetool statusbackup

Provide the status of backup

### Synopsis

```
$ nodetool <options> statusbackup
```

options are:

- ( `-h` | `--host` ) <host name> | <ip address>
- ( `-p` | `--port` ) <port number>
- ( `-pw` | `--password` ) <password >
- ( `-u` | `--username` ) <user name>
- ( `-pwf` <passwordFilePath> | `--password-file` <passwordFilePath> )

### Synopsis Legend

In the synopsis section of each statement, formatting has the following meaning:

- Uppercase means literal
- Lowercase means not literal
- Italics mean optional
- The pipe (|) symbol means OR or AND/OR
- Ellipsis (...) means repeatable
- Orange ( and ) means not literal, indicates scope

A semicolon that terminates CQL statements is not included in the synopsis.

### Description

Provides the status of backup.

## nodetool statusbinary

Provide the status of native transport.

Provide the status of native transport.

### Synopsis

```
$ nodetool <options> statusbinary
```

options are:

- ( -h | --host ) <host name> | <ip address>
- ( -p | --port ) <port number>
- ( -pw | --password ) <password >
- ( -u | --username ) <user name>
- ( -pwf <passwordFilePath | --password-file <passwordFilePath> )

### Synopsis Legend

- Angle brackets (< >) mean not literal, a variable
- Italics mean optional
- The pipe (|) symbol means OR or AND/OR
- Ellipsis (...) means repeatable
- Orange ( and ) means not literal, indicates scope

### Description

Provides the status of the binary protocol, also known as the native transport.

## nodetool statusgossip

Provide the status of gossip.

### Synopsis

```
$ nodetool <options> statusgossip
```

options are:

- ( -h | --host ) <host name> | <ip address>
- ( -p | --port ) <port number>
- ( -pw | --password ) <password >

- ( -u | --username ) <user name>
- ( -pwf <passwordFilePath | --password-file <passwordFilePath> )

### Synopsis Legend

- Angle brackets (< >) mean not literal, a variable
- Italics mean optional
- The pipe (|) symbol means OR or AND/OR
- Ellipsis (...) means repeatable
- Orange ( and ) means not literal, indicates scope

### Description

Provides the status of gossip.

## nodetool statushandoff

Provides the status of hinted handoff.

### Synopsis

```
$ nodetool <options> statushandoff
```

options are:

- ( -h | --host ) <host name> | <ip address>
- ( -p | --port ) <port number>
- ( -pw | --password ) <password >
- ( -u | --username ) <user name>
- ( -pwf <passwordFilePath | --password-file <passwordFilePath> )

### Synopsis Legend

In the synopsis section of each statement, formatting has the following meaning:

- Uppercase means literal
- Lowercase means not literal
- Italics mean optional
- The pipe (|) symbol means OR or AND/OR
- Ellipsis (...) means repeatable
- Orange ( and ) means not literal, indicates scope

A semicolon that terminates CQL statements is not included in the synopsis.

### Description

Provides the status of hinted handoff.

## nodetool statusthrift

Provide the status of the Thrift server.

Provide the status of the Thrift server.

### Synopsis

```
$ nodetool <options> statusthrift
```

options are:

## Cassandra tools

- ( -h | --host ) <host name> | <ip address>
- ( -p | --port ) <port number>
- ( -pw | --password ) <password >
- ( -u | --username ) <user name>
- ( -pwf <passwordFilePath | --password-file <passwordFilePath> )

### Synopsis Legend

- Angle brackets (< >) mean not literal, a variable
- Italics mean optional
- The pipe (|) symbol means OR or AND/OR
- Ellipsis (...) means repeatable
- Orange ( and ) means not literal, indicates scope

## nodetool stop

Stops the compaction process.

Stops the compaction process.

### Synopsis

```
$ nodetool <options> stop -- <compaction_type>
```

- options are:
  - ( -h | --host ) <host name> | <ip address>
  - ( -p | --port ) <port number>
  - ( -pw | --password ) <password >
  - ( -u | --username ) <user name>
  - ( -pwf <passwordFilePath | --password-file <passwordFilePath> )
- -- separates an option and argument that could be mistaken for a option.
- A compaction type: COMPACTION, VALIDATION, CLEANUP, SCRUB, INDEX\_BUILD

### Synopsis Legend

- Angle brackets (< >) mean not literal, a variable
- Italics mean optional
- The pipe (|) symbol means OR or AND/OR
- Ellipsis (...) means repeatable
- Orange ( and ) means not literal, indicates scope

### Description

Stops an operation from continuing to run. This command is typically used to stop a compaction that has a negative impact on the performance of a node. After the compaction stops, Cassandra continues with the remaining operations in the queue. Eventually, Cassandra restarts the compaction.

## nodetool stopdaemon

Stops the cassandra daemon.

Stops the cassandra daemon.

### Synopsis

```
$ nodetool <options> stopdaemon
```

options are:

- ( -h | --host ) <host name> | <ip address>
- ( -p | --port ) <port number>
- ( -pw | --password ) <password >
- ( -u | --username ) <user name>
- ( -pwf <passwordFilePath | --password-file <passwordFilePath> )

### Synopsis Legend

- Angle brackets (< >) mean not literal, a variable
- Italics mean optional
- The pipe (|) symbol means OR or AND/OR
- Ellipsis (...) means repeatable
- Orange ( and ) means not literal, indicates scope

## nodetool tpstats

Provides usage statistics of thread pools.

Provides usage statistics of thread pools.

### Synopsis

```
$ nodetool <options> tpstats
```

options are:

- ( -h | --host ) <host name> | <ip address>
- ( -p | --port ) <port number>
- ( -pw | --password ) <password>
- ( -u | --username ) <user name>
- ( -pwf <passwordFilePath | --password-file <passwordFilePath> )

### Synopsis Legend

- Angle brackets (< >) mean not literal, a variable
- Italics mean optional
- The pipe (|) symbol means OR or AND/OR
- Ellipsis (...) means repeatable
- Orange ( and ) means not literal, indicates scope

### Description

Cassandra is based on a Staged Event Driven Architecture (SEDA). Different tasks are separated into stages that are connected by a messaging service. Stages have a queue and thread pool. Some stages skip the messaging service and queue tasks immediately on a different stage if it exists on the same node. The queues can back up if executing at the next stage is too busy. Having a queue get backed up can cause performance bottlenecks. `nodetool tpstats` provides statistics about the number of active, pending, and completed tasks for each stage of Cassandra operations by thread pool. A high number of pending tasks for any pool can indicate performance problems, as described in <http://wiki.apache.org/cassandra/Operations#Monitoring>.

Run the `nodetool tpstats` command on a local node for get thread pool statistics.

This table describes key indicators:

Table 12: nodetool tpstats output

Name of statistic	Task	Related information
AntiEntropyStage	Repair consistency	Nodetool repair
CacheCleanupExec	Clears the cache	
CommitlogArchive	Archives commitlog	
CompactionExec	Runs compaction	
CounterMutationStage	Local counter changes	Will back up if the write rate exceeds the mutation rate. A high pending count will be seen if consistency level is set to ONE and there is a high counter increment workload.
GossipStage	Handle gossip rounds every second	Out of sync schemas can cause issues. <code>nodetool resetlocalschema</code> may need to be used.
HintedHandoff	Send missed mutations to other nodes	Usually symptom of a problem elsewhere. Use <code>nodetool disablehandoff and run repair</code> .
InternalResponseStage	Respond to non-client initiated messages, including bootstrapping and schema checking	
MemtableFlushWrite	Writes memtable contents to disk	Will back up if the queue is overrunning the disk I/O capabilities. Sorting can also cause issues if the queue has a high load associated with a small number of flushes. Cause can be huge rows with large column names or inserting too many values into a CQL collection. For disk issues, add nodes or tune configuration.
MemtablePostFlushOp	Operations after flushing the memtable	Discard commit log files and flush secondary indexes.
MemtableReclaimMemory	Makes unused memory available	
MigrationStage	Make schema changes	
MiscStage	Miscellaneous operations	Snapshotting, replicating data after node remove completed.
MutationStage	Local writes	A high number of pending write requests indicates a problem handling them. Adding a node, tuning hardware and configuration, or updating data models will improve handling.



Name of statistic	Task	Related information
PendingRangeCalculator	Calculate pending ranges per bootstraps and departed nodes	Developer notes
ReadRepairStage	A <b>digest query</b> and update of replicas of a key	Fast providing good connectivity between replicas exists. If pending grows too large, attempt to lower the rate for high-read tables by altering the table to use a smaller read_repair_chance value, like 0.11.
ReadStage	Local reads	Performing a local read. Also includes deserializing data from row cache. Pending values can cause increased read latency. Generally resolved by adding nodes or tuning the system.
RequestResponseStage	Request responses from other nodes	
ValidationExecutor	Validates schema	

**Table 13: Droppable Messages**

Message Type	Stage	Notes
BINARY	n/a	This is deprecated and no longer has any use
_TRACE	n/a (special)	Used for recording traces (nodetool settraceprobability) Has a special executor (1 thread, 1000 queue depth) that throws away messages on insertion instead of within the execute
MUTATION	<b>MutationStage</b>	If a write message is processed after its timeout (write_request_timeout_in_ms) it either sent a failure to the client or it met its requested consistency level and will relay on hinted handoff and read repairs to do the mutation if it succeeded.
COUNTER_MUTATION	<b>MutationStage</b>	If a write message is processed after its timeout (write_request_timeout_in_ms) it either sent a failure to the client or it met its requested consistency level and will relay on hinted handoff and read repairs to do the mutation if it succeeded.
READ_REPAIR	<b>MutationStage</b>	Times out after write_request_timeout_in_ms

READ	ReadStage	Times out after read_request_timeout_in_ms. No point in servicing reads after that point since it would of returned error to client
RANGE_SLICE	ReadStage	Times out after range_request_timeout_in_ms.
PAGED_RANGE	ReadStage	Times out after request_timeout_in_ms.
REQUEST_RESPONSE	RequestResponseStage	Times out after request_timeout_in_ms. Response was completed and sent back but not before the timeout

**Example**

Run the command every two seconds.

```
$ nodetool -h labcluster tpstats
```

Example output is:

Pool Name	Active	Pending	Completed	Blocked	All
time blocked					
CounterMutationStage	0	0	0	0	
0					
ReadStage	0	0	103	0	
0					
RequestResponseStage	0	0	0	0	
0					
MutationStage	0	0	13234794	0	
0					
ReadRepairStage	0	0	0	0	
0					
GossipStage	0	0	0	0	
0					
CacheCleanupExecutor	0	0	0	0	
0					
AntiEntropyStage	0	0	0	0	
0					
MigrationStage	0	0	11	0	
0					
ValidationExecutor	0	0	0	0	
0					
CommitLogArchiver	0	0	0	0	
0					
MiscStage	0	0	0	0	
0					
MemtableFlushWriter	0	0	126	0	
0					
MemtableReclaimMemory	0	0	126	0	
0					
PendingRangeCalculator	0	0	1	0	
0					
MemtablePostFlush	0	0	1468	0	
0					
CompactionExecutor	0	0	254	0	
0					

InternalResponseStage	0	0	1	0
0				
HintedHandoff	0	0	0	
Message type	Dropped			
RANGE_SLICE	0			
READ_REPAIR	0			
PAGED_RANGE	0			
BINARY	0			
READ	0			
MUTATION	180			
_TRACE	0			
REQUEST_RESPONSE	0			
COUNTER_MUTATION	0			

## nodetool truncatehints

Truncates all hints on the local node, or truncates hints for the one or more endpoints.

Truncates all hints on the local node, or truncates hints for the one or more endpoints.

### Synopsis

```
$ nodetool <options> truncatehints -- ( <endpoint> ... )
```

- options are:
  - ( -h | --host ) <host name> | <ip address>
  - ( -p | --port ) <port number>
  - ( -pw | --password ) <password >
  - ( -u | --username ) <user name>
  - ( -pwf <passwordFilePath | --password-file <passwordFilePath> )
- separates an option and argument that could be mistaken for a option.
- endpoint is one or more endpoint IP addresses or host names which hints are to be deleted.

### Synopsis Legend

- Angle brackets (< >) mean not literal, a variable
- Italics mean optional
- The pipe (|) symbol means OR or AND/OR
- Ellipsis (...) means repeatable
- Orange ( and ) means not literal, indicates scope

## nodetool upgradesstables

Rewrites older SSTables to the current version of Cassandra.

Rewrites older SSTables to the current version of Cassandra.

### Synopsis

```
$ nodetool <options> upgradesstables
( -a | --include-all-sstables )
-- <keyspace> ( <table> ... )
```

- options are:
  - ( -h | --host ) <host name> | <ip address>
  - ( -p | --port ) <port number>
  - ( -pw | --password ) <password >

## Cassandra tools

- ( `-u` | `--username` ) `<user name>`
- ( `-pwf` `<passwordFilePath` | `--password-file` `<passwordFilePath>` )
- `-a` or `--include-all-sstables` includes all SSTables, even those with the current settings. See [Examples](#) below.
- `--` separates an option and argument that could be mistaken for a option.
- `keyspace` is the keyspace name.
- `table` is one or more table names, separated by a space.

### Synopsis Legend

- Angle brackets (`<` `>`) mean not literal, a variable
- Italics mean optional
- The pipe (`|`) symbol means OR or AND/OR
- Ellipsis (`...`) means repeatable
- Orange ( `and` ) means not literal, indicates scope

### Description

Rewrites SSTables on a node that are incompatible with the current version. Use this command when upgrading your server or changing compression options.

### Examples

```
$ upgradesstables
```

Reads only SSTables created by old major versions of Cassandra and re-writes them to the current version one at a time.

```
$ upgradesstables -a
```

Reads all existing SSTables and re-writes them to the current Cassandra version one at a time.

```
$ upgradesstables -a keyspace table
```

Reads specific SSTables and re-writes them to the current Cassandra version one at a time.

## nodetool version

Provides the version number of Cassandra running on the specified node.

Provides the version number of Cassandra running on the specified node.

### Synopsis

```
$ nodetool <options> version
```

options are:

- ( `-h` | `--host` ) `<host name>` | `<ip address>`
- ( `-p` | `--port` ) `<port number>`
- ( `-pw` | `--password` ) `<password >`
- ( `-u` | `--username` ) `<user name>`
- ( `-pwf` `<passwordFilePath` | `--password-file` `<passwordFilePath>` )

### Synopsis Legend

- Angle brackets (`<` `>`) mean not literal, a variable
- Italics mean optional
- The pipe (`|`) symbol means OR or AND/OR
- Ellipsis (`...`) means repeatable
- Orange ( `and` ) means not literal, indicates scope

## Cassandra bulk loader (sstableloader)

Provides the ability to bulk load external data into a cluster, load existing SSTables into another cluster with a different number of nodes or replication strategy, and restore snapshots.

### About this task

The Cassandra bulk loader, also called the sstableloader, provides the ability to:

- Bulk load external data into a cluster.
- Load existing SSTables into another cluster with a different number of nodes or replication strategy.
- Restore snapshots.

The sstableloader streams a set of SSTable data files to a live cluster; it does not simply copy the set of SSTables to every node, but transfers the relevant part of the data to each node, conforming to the replication strategy of the cluster. The table into which the data is loaded does not need to be empty.

If tables are repaired in a different cluster, after being loaded, the tables will be unrepaired.

### Prerequisites

Because sstableloader uses Cassandra gossip, make sure of the following:

- The `cassandra.yaml` configuration file is in the classpath and properly configured.
- At least one node in the cluster is configured as seed.
- In the `cassandra.yaml` file, the following properties are properly configured for the cluster that you are importing into:
  - `cluster_name`
  - `listen_address`
  - `storage_port`
  - `rpc_address`
  - `rpc_port`

When using sstableloader to load external data, you must first generate SSTables.

If using DataStax Enterprise, you can use [Sqoop](#) to migrate external data to Cassandra.

### Generating SSTables

SSTableWriter is the API to create raw Cassandra data files locally for bulk load into your cluster. The Cassandra source code includes the CQLSSTableWriter implementation for creating SSTable files from external data without needing to understand the details of how those map to the underlying storage engine. Import the `org.apache.cassandra.io.sstable.CQLSSTableWriter` class, and define the schema for the data you want to import, a writer for the schema, and a prepared insert statement, as shown in [Cassandra 2.0.1](#), [2.0.2](#), and [a quick peek at 2.0.3](#).

### Using sstableloader

Before loading the data, you must define the schema of the tables with [CQL](#) or Thrift.

To get the best throughput from SSTable loading, you can use multiple instances of sstableloader to stream across multiple machines. No hard limit exists on the number of SSTables that sstableloader can run at the same time, so you can add additional loaders until you see no further improvement.

If you use sstableloader on the same machine as the Cassandra node, you can't use the same network interface as the Cassandra node. However, you can use the JMX **StorageService > bulkload()** call from that node. This method takes the absolute path to the directory where the SSTables are located, and loads them just as sstableloader does. However, because the node is both source and destination for the streaming, it increases the load on that node. This means that you should load data from machines that are not Cassandra nodes when loading into a live cluster.

**Usage:**

Package installations:

```
$ sstableloader [options] path_to_keyspace
```

Tarball installations:

```
$ cd install_location/bin
$ sstableloader [options] path_to_keyspace
```

The sstableloader bulk loads the SSTables found in the keyspace directory to the configured target cluster, where the parent directories of the directory path are used as the target keyspace/table name.

1. Go to the location of the SSTables:

```
$ cd /var/lib/cassandra/data/Keyspace1/Standard1/
```

2. To view the contents of the keyspace:

```
$ ls
Keyspace1-Standard1-jb-60-CRC.db
Keyspace1-Standard1-jb-60-Data.db
...
Keyspace1-Standard1-jb-60-TOC.txt
```

3. To bulk load the files, specify the path to Keyspace1/Standard1/ in the target cluster:

```
$ sstableloader -d 110.82.155.1 /var/lib/cassandra/data/Keyspace1/Standard1/
## package installation

$ install_location/bin/sstableloader -d 110.82.155.1 /var/lib/cassandra/
data/Keyspace1/Standard1/ ## tarball installation
```

This bulk loads all files.

**Table 14: sstableloader options**

Short option	Long option	Description
-alg	--ssl-alg <ALGORITHM>	Client SSL algorithm (default: SunX509).
-ciphers	--ssl-ciphers <CIPHER-SUITES>	Client SSL. Comma-separated list of encryption suites.
-cph	--connections-per-host <connectionsPerHost>	Number of concurrent connections-per-host.
-d	--nodes <initial_hosts>	Required. Connect to a list of (comma separated) hosts for initial cluster information.
-f	--conf-path <path_to_config_file>	Path to the <code>cassandra.yaml</code> path for streaming throughput and client/server SSL.
-h	--help	Display help.
-i	--ignore <NODES>	Do not stream to this comma separated list of nodes.
-ks	--keystore <KEYSTORE>	Client SSL. Full path to the keystore.

Short option	Long option	Description
-kspw	--keystore-password <KEYSTORE-PASSWORD>	Client SSL. Password for the keystore.
	--no-progress	Do not display progress.
-p	--port <rpc port>	RPC port (default: 9160 [Thrift]).
-prtcl	--ssl-protocol <PROTOCOL>	Client SSL. Connections protocol to use (default: TLS).
-pw	--password <password>	Password for Cassandra authentication.
-st	--store-type <STORE-TYPE>	Client SSL. Type of store.
-t	--throttle <throttle>	Throttle speed in Mbits (default: unlimited).
-tf	--transport-factory <transport factory>	Fully-qualified <code>ITransportFactory</code> class name for creating a connection to Cassandra.
-ts	--truststore <TRUSTSTORE>	Client SSL. Full path to truststore.
-tspw	--truststore-password <TRUSTSTORE-PASSWORD>	Client SSL. Password of the truststore.
-u	--username <username>	User name for Cassandra authentication.
-v	--verbose	Verbose output.

The following `cassandra.yaml` options can be over-ridden from the command line:

Option in <code>cassandra.yaml</code>	Command line example
<code>stream_throughput_outbound_megabits_per_sec</code>	<code>--throttle 300</code>
<code>server_encryption_options</code>	<code>--ssl-protocol none</code>
<code>client_encryption_options</code>	<code>--keystore-password MyPassword</code>

The location of the `cassandra.yaml` file depends on the type of installation:

Package installations	<code>/etc/cassandra/cassandra.yaml</code>
Tarball installations	<code>install_location/resources/cassandra/conf/cassandra.yaml</code>

## The `cassandra` utility

Cassandra start-up parameters can be run from the command line (in Tarball installations) or specified in the `cassandra-env.sh` file (Package or Tarball installations).

### About this task

Cassandra start-up parameters can be run from the command line (Tarball installations) or specified in the `cassandra-env.sh` file (Package or Tarball installations).

## Cassandra tools

**Note:** You can also use the `cassandra-env.sh` file to pass additional options, such as maximum and minimum heap size, to the Java virtual machine rather than setting them in the environment.

The location of the `cassandra.yaml` file depends on the type of installation:

Package installations	<code>/etc/cassandra/cassandra.yaml</code>
Tarball installations	<code>install_location/resources/cassandra/conf/cassandra.yaml</code>

The location of the `cassandra-env.sh` file depends on the type of installation:

Package installations	<code>/etc/cassandra/cassandra-env.sh</code>
Tarball installations	<code>install_location/conf/cassandra-env.sh</code>

## Usage

Add the following to the `cassandra-env.sh` file:

```
JVM_OPTS="$JVM_OPTS -D[PARAMETER]"
```

The location of the `cassandra-env.sh` file depends on the type of installation:

Package installations	<code>/etc/cassandra/cassandra-env.sh</code>
Tarball installations	<code>install_location/conf/cassandra-env.sh</code>

For Tarball installations, you can run this tool from the command line:

```
$ cassandra [OPTIONS]
```

Examples:

- `cassandra-env.sh: JVM_OPTS="$JVM_OPTS -Dcassandra.load_ring_state=false"`
- `Command line: bin/cassandra -Dcassandra.load_ring_state=false`

The [Example section](#) contains more examples.

## Command line only options

Option	Description
<code>-f</code>	Start the cassandra process in foreground. The default is to start as background process.
<code>-h</code>	Help.
<code>-p filename</code>	Log the process ID in the named file. Useful for stopping Cassandra by killing its PID.
<code>-v</code>	Print the version and exit.

## Start-up parameters

The `-D` option specifies the start-up parameters in both the command line and `cassandra-env.sh` file.

### `cassandra.auto_bootstrap=false`

Facilitates setting `auto_bootstrap` to false on initial set-up of the cluster. The next time you start the cluster, you do not need to change the `cassandra.yaml` file on each node to revert to true.

### `cassandra.available_processors=number_of_processors`



In a multi-instance deployment, multiple Cassandra instances will independently assume that all CPU processors are available to it. This setting allows you to specify a smaller set of processors.

**cassandra.boot\_without\_jna=true**

If JNA fails to initialize, Cassandra fails to boot. Use this command to boot Cassandra without JNA.

**cassandra.config=directory**

The directory location of the `cassandra.yaml` file. The default location depends on the type of installation.

**cassandra.initial\_token=token**

Use when virtual nodes (vnodes) are not used. Sets the initial partitioner token for a node the first time the node is started. (Default: disabled)

**Note:** Vnodes are highly recommended as they automatically select tokens.

**cassandra.join\_ring=true/false**

Set to false to start Cassandra on a node but not have the node join the cluster. (Default: true) You can use [nodetool join](#) and a JMX call to join the ring afterwards.

**cassandra.load\_ring\_state=true/false**

Set to false to clear all gossip state for the node on restart. (Default: true)

**cassandra.metricsReporterConfigFile=file**

Enable pluggable metrics reporter. See [Pluggable metrics reporting in Cassandra 2.0.2](#).

**cassandra.native\_transport\_port=port**

Set the port on which the CQL native transport listens for clients. (Default: 9042)

**cassandra.partitioner=partitioner**

Set the partitioner. (Default: `org.apache.cassandra.dht.Murmur3Partitioner`)

**cassandra.replace\_address=listen\_address or broadcast\_address of dead node**

To replace a node that has died, restart a new node in its place specifying the `listen_address` or `broadcast_address` that the new node is assuming. The new node must not have any data in its data directory, that is, it must be in the same state as before bootstrapping.

**Note:** The `broadcast_address` defaults to the `listen_address` except when using the [Ec2MultiRegionSnitch](#).

**cassandra.replayList=table**

Allow restoring specific tables from an archived commit log.

**cassandra.ring\_delay\_ms=ms**

Defines the amount of time a node waits to hear from other nodes before formally joining the ring. (Default: 1000ms)

**cassandra.rpc\_port=port**

Set the port for the Thrift RPC service, which is used for client connections. (Default: 9160).

**cassandra.ssl\_storage\_port=port**

Set the SSL port for encrypted communication. (Default: 7001)

**cassandra.start\_native\_transport=true/false**

Enable or disable the native transport server. See [start\\_native\\_transport](#) in `cassandra.yaml`. (Default: true)

**cassandra.start\_rpc=true/false**

Enable or disable the Thrift RPC server. (Default: true)

**cassandra.storage\_port=port**

Set the port for inter-node communication. (Default: 7000)

**cassandra.triggers\_dir=directory**

Set the default location for the trigger JARs. (Default: `conf/triggers`)

## Cassandra tools

### `cassandra.write_survey=true`

For testing new compaction and compression strategies. It allows you to experiment with different strategies and benchmark write performance differences without affecting the production workload. See [Testing compaction and compression](#).

### `consistent.rangemovement=true`

True makes [Cassandra 2.1 bootstrapping](#) behavior effective. False makes Cassandra 2.0 behavior effective.

### Example

#### Clear gossip state when starting a node:

- Command line: `bin/cassandra -Dcassandra.load_ring_state=false`
- `cassandra-env.sh`: `JVM_OPTS="$JVM_OPTS -Dcassandra.load_ring_state=false"`

#### Start Cassandra on a node and do not join the cluster:

- Command line: `bin/cassandra -Dcassandra.join_ring=false`
- `cassandra-env.sh`: `JVM_OPTS="$JVM_OPTS -Dcassandra.join_ring=false"`

#### Replacing a dead node:

- Command line: `bin/cassandra -Dcassandra.replace_address=10.91.176.160`
- `cassandra-env.sh`: `JVM_OPTS="$JVM_OPTS -Dcassandra.replace_address=10.91.176.160"`

## The `cassandra-stress` tool

A Java-based stress testing utility for basic benchmarking and load testing a Cassandra cluster.

### About this task

The `cassandra-stress` tool is a Java-based stress testing utility for basic benchmarking and load testing a Cassandra cluster.

The choices you make when data modeling your application can make a big difference in how your application performs. Creating the best data model requires significant load testing and multiple iterations. The `cassandra-stress` tool helps you in this endeavor by populating your cluster and supporting stress testing of arbitrary CQL tables and arbitrary queries on tables. Use the `cassandra-stress` tool to:

- Quickly determine how a schema performs.
- Understand how your database scales.
- Optimize your data model and settings.
- Determine production capacity.

**Note:** You can also use this tool on Cassandra 2.0 clusters.

The `cassandra-stress` tool also supports a YAML-based profile for defining specific schema with potential compaction strategies, cache settings, and types. Sample files are located in:

- Package installations: `/usr/share/doc/cassandra/examples`
- Tarball installations: `install_location/tools`

For a complete description on using these sample files, see [Improved Cassandra 2.1 Stress Tool: Benchmark Any Schema – Part 1](#).

The `cassandra-stress` tool creates a keyspace called `keyspace1` and within that, tables named `standard1`, `counter1`, depending on what type of table is being tested. These are automatically created the first time you run the stress test and are reused on subsequent runs unless you drop the keyspace using [CQL](#). You cannot change the names; they are hard-coded.

Usage:

- Package installations: `cassandra-stress command [options]`
- Tarball installations: `install_location/tools/bin/cassandra-stress command [options]`

On tarball installations, you can use these commands and options with or without the `cassandra-stress daemon` running.

Command	Description
read	Multiple concurrent reads. The cluster must first be populated by a write test.
write	Multiple concurrent writes against the cluster.
mixed	Interleave basic commands with configurable ratio and distribution. The cluster must first be populated by a write test.
counter_write	Multiple concurrent updates of counters.
counter_read	Multiple concurrent reads of counters. The cluster must first be populated by a counter_write test.
user	Interleave user provided queries with configurable ratio and distribution.
help	Display help for a command or option. Display help for an option: <code>cassandra-stress help [options]</code> For example: <code>cassandra-stress help -schema</code>
print	Inspect the output of a distribution definition.
legacy	Legacy support mode.

**Important:** Additional sub options are available for each option in the following table. Format:

```
$ cassandra-stress help option
```

For an example, see [View schema help](#).

Option	Description
<b>-pop</b>	Population distribution and intra-partition visit order.
Usage	<code>\$ -pop seq=? [no-wrap] [read-lookback=DIST(?)] [contents=?]</code> or <code>-pop [dist=DIST(?)] [contents=?]</code>
<b>-insert</b>	Insert specific options relating to various methods for batching and splitting partition updates.
Usage	<code>\$ -insert [revisit=DIST(?)] [visits=DIST(?)] partitions=DIST(?)</code> <code>[batchtype=?] select-ratio=DIST(?)</code>
<b>-col</b>	Column details, such as size and count distribution, data generator, names, and comparator.
Usage	<code>\$ -col [n=DIST(?)] [slice] [super=?] [comparator=?] [timestamp=?]</code> <code>[size=DIST(?)]</code>
<b>-rate</b>	Thread count, rate limit, or automatic mode (default is auto).
Usage	<code>\$ -rate threads=? [limit=?]</code> or

Option	Description
	\$ -rate [threads>=?] [threads<=?] [auto]
<b>-mode</b>	Thrift or CQL with options.
Usage	\$ -mode thrift cql2 [prepared]
<b>-errors</b>	How to handle errors when encountered during stress.
Usage	\$ -errors [retries=?] [ignore]
<b>-sample</b>	Specify the number of samples to collect for measuring latency.
Usage	\$ -sample [history=?] [live=?] [report=?]
<b>-schema</b>	Replication settings, compression, compaction, and so on.
Usage	\$ -schema [replication(?)] [keyspace=?] [compaction(?)] [compression=?]
<b>-node</b>	Nodes to connect to.
Usage	\$ -node [whitelist] [file=?] []
<b>-log</b>	Where to log progress and the interval to use.
Usage	\$ -log [level=?] [no-summary] [file=?] [interval=?]
<b>-transport</b>	Custom transport factories.
Usage	\$ -transport [factory=?] [truststore=?] [truststore-password=?] [ssl-protocol=?] [ssl-alg=?] [store-type=?] [ssl-ciphers=?]
<b>-port</b>	Specify port for connecting Cassandra nodes.
Usage	\$ -port [native=?] [thrift=?] [jmx=?]
<b>-sendto</b>	Specify stress server to send this command to.
Usage	\$ -sendToDaemon <host>

### View schema help

```
$ cassandra-stress help -schema
```

```

replication([strategy=?][factor=?][<option 1..N>=?]):           Define
  the replication strategy and any parameters
  strategy=? (default=org.apache.cassandra.locator.SimpleStrategy) The
  replication strategy to use
  factor=? (default=1)                                           The
  number of replicas
keyspace=? (default=keyspace1)                                   The
  keyspace name to use

```

```

compaction([strategy=?][<option 1..N>=?]):           Define
  the compaction strategy and any parameters
  strategy=?                                         The
  compaction strategy to use
compression=?
  Specify the compression to use for SSTable, default:no compression

```

## Populate the database

Generally it is easier to let `cassandra-stress` create the basic schema and then modify it in [CQL](#):

```

#Load one row with default schema
$ cassandra-stress write n=1 cl=one -mode native cql3 -log file=~/  
create_schema.log

#Modify schema in CQL
$ cqlsh

#Run a real write workload
$ cassandra-stress write n=1000000 cl=one -mode native cql3 -schema  
keyspace="keyspace1" -log file=~/load_1M_rows.log

```

## Running a mixed workload

When running a mixed workload, you must escape parentheses, greater-than and less-than signs, and other such things. This example invokes a workload that is one-quarter writes and three-quarters reads.

```

$ cassandra-stress mixed ratio\<(write=1,read=3\) n=100000 cl=ONE -pop  
dist=UNIFORM\<(1..1000000\) -schema keyspace="keyspace1" -mode native cql3 -  
rate threads\<>=16 threads\<<=256 -log file=~/  
mixed_atorate_50r50w_1M.log

```

Notice the following in this example:

1. The `ratio` requires backslash-escaped parenthesis.
2. The value of `n` is different than in write phase. During the write phase, `n` records are written. However in the read phase, if `n` is too large, it is inconvenient to read *all* the records for simple testing. Generally, `n` does not need be large when validating the persistent storage systems of a cluster.

The `-pop dist=UNIFORM\<(1..1000000\)` portion says that of the `n=100,000` operations, select the keys uniformly distributed between 1 and 1,000,000. Use this when you want to specify more data per node than what fits in DRAM.

3. In the `rate` section, the greater-than and less-than signs are escaped. If not escaped, the shell will attempt to use them for IO redirection. Specifically, the shell will try to read from a non-existent file called `=256` and create a file called `=16`. The `rate` section tells `cassandra-stress` to automatically attempt different numbers of client threads and not test less than 16 or more than 256 client threads.

## Standard mixed read/write workload keyspace for a single node

```

CREATE KEYSPACE "keyspace1" WITH replication = {
  'class': 'SimpleStrategy',
  'replication_factor': '1'
};
USE "keyspace1";
CREATE TABLE "standard1" (
  key blob,
  "C0" blob,
  "C1" blob,
  "C2" blob,

```

## Cassandra tools

```
"C3" blob,  
"C4" blob,  
PRIMARY KEY (key)  
) WITH  
bloom_filter_fp_chance=0.010000 AND  
caching='KEYS_ONLY' AND  
comment='' AND  
dclocal_read_repair_chance=0.000000 AND  
gc_grace_seconds=864000 AND  
index_interval=128 AND  
read_repair_chance=0.100000 AND  
replicate_on_write='true' AND  
default_time_to_live=0 AND  
speculative_retry='99.0PERCENTILE' AND  
memtable_flush_period_in_ms=0 AND  
compaction={'class': 'SizeTieredCompactionStrategy'} AND  
compression={'sstable_compression': 'LZ4Compressor'};
```

### Splitting up a load over multiple cassandra-stress instances on different nodes

This example is useful for loading into large clusters, where a single cassandra-stress load generator node cannot saturate the cluster. In this example, \$NODES is a variable whose value is a comma delimited list of IP addresses such as 10.0.0.1,10.0.0.2, and so on.

```
#On Node1  
$ cassandra-stress write n=1000000 cl=one -mode native cql3 -schema  
  keyspace="keyspace1" -pop seq=1..1000000 -log file=~/node1_load.log -node  
  $NODES  
  
#On Node2  
$ cassandra-stress write n=1000000 cl=one -mode native cql3 -schema  
  keyspace="keyspace1" -pop seq=1000001..2000000 -log file=~/node2_load.log -  
  node $NODES
```

Note the keyspace is defined and the `-key` option tells each instance which range of keys to populate.

### Using the Daemon Mode

The daemon in larger-scale testing can prevent potential skews in the test results by keeping the JVM warm.

The daemon is only available in tarball installations. Run the daemon from:

```
install_location/tools/bin/cassandra-stressd start|stop|status [-h  
<host>]
```

During stress testing, you can keep the daemon running and send it commands through it using the `--send-to` option.

#### Example

- Insert 1,000,000 rows to given host:

```
/tools/bin/cassandra-stress -d 192.168.1.101
```

When the number of rows is not specified, one million rows are inserted.

- Read 1,000,000 rows from given host:

```
tools/bin/cassandra-stress -d 192.168.1.101 -o read
```

- Insert 10,000,000 rows across two nodes:

```
/tools/bin/cassandra-stress -d 192.168.1.101,192.168.1.102 -n 10000000
```

- Insert 10,000,000 rows across two nodes using the daemon mode:

```
/tools/bin/cassandra-stress -d 192.168.1.101,192.168.1.102 -n 10000000 --
send-to 54.0.0.1
```

## Interpreting the output of cassandra-stress

About the output from the running tests.

Each line reports data for the interval between the last elapsed time and current elapsed time.

```
Created keyspaces. Sleeping 1s for propagation.
Warming up WRITE with 50000 iterations...
INFO 23:57:05 Using data-center name 'datacenter1' for
  DCAwareRoundRobinPolicy (if this is incorrect, please provide the correct
  datacenter name with DCAwareRoundRobinPolicy constructor)
Connected to cluster: Test Cluster
Datacenter: datacenter1; Host: localhost/127.0.0.1; Rack: rack1
INFO 23:57:05 New Cassandra host localhost/127.0.0.1:9042 added
Sleeping 2s...
WARNING: uncertainty mode (err<) results in uneven workload between thread
  runs, so should be used for high level analysis only
Running with 4 threadCount
Running WRITE with 4 threads until stderr of mean < 0.02
total ops , adj row/s,   op/s,   pk/s,   row/s,   mean,   med,   .95,
  .99,   .999,   max,   time,   stderr, gc: #, max ms, sum ms, sdv
ms,      mb
2552 ,      2553,   2553,   2553,   2553,   1.5,   1.4,   2.5,
  6.0,   12.6,   18.0,   1.0,   0.00000,   0,   0,   0,
  0,      0
5173 ,      2634,   2613,   2613,   2613,   1.5,   1.5,   1.8,
  2.6,   8.6,   9.2,   2.0,   0.00000,   0,   0,   0,
  0,      0
...

Results:
op rate           : 3954
partition rate    : 3954
row rate          : 3954
latency mean      : 1.0
latency median    : 0.8
latency 95th percentile : 1.5
latency 99th percentile : 1.8
latency 99.9th percentile : 2.2
latency max       : 73.6
total gc count     : 25
total gc mb       : 1826
total gc time (s) : 1
avg gc time(ms)   : 37
stdev gc time(ms) : 10
Total operation time : 00:00:59
Sleeping for 15s
Running with 4 threadCount
```

**Table 15: Output of `cassandra-stress`**

Data	Description
<code>total ops</code>	Running total number of operations during the run.
<code>op/s</code>	Number of operations per second performed during the run.
<code>pk/s</code>	Number of partition operations per second performed during the run.
<code>row/s</code>	Number of row operations per second performed during the run.
<code>mean</code>	Average latency in milliseconds for each operation during that run.
<code>med</code>	Median latency in milliseconds for each operation during that run.
<code>.95</code>	95% of the time the latency was less than the number displayed in the column.
<code>.99</code>	99% of the time the latency was less than the number displayed in the column.
<code>.999</code>	99.9% of the time the latency was less than the number displayed in the column.
<code>max</code>	Maximum latency in milliseconds.
<code>time</code>	Total operation time.
<code>stderr</code>	Standard error of the mean. It is a measure of confidence in the average throughput number; the smaller the number, the more accurate the measure of the cluster's performance.
<code>gc: #</code>	Number of garbage collections.
<code>max ms</code>	Longest garbage collection in milliseconds.
<code>sum ms</code>	Total of garbage collection in milliseconds.
<code>sdv ms</code>	Standard deviation in milliseconds.
<code>mb</code>	Size of the garbage collection in megabytes.

## The `sstablescrub` utility

An offline version of `nodetool scrub`. It attempts to remove the corrupted parts while preserving non-corrupted data.

### About this task

The `sstablescrub` utility is an offline version of `nodetool scrub`. It attempts to remove the corrupted parts while preserving non-corrupted data. Because `sstablescrub` runs offline, it can correct errors that `nodetool scrub` cannot.

If scrubbing results in dropping rows, new SSTables become unrepaired. However, if no bad rows are detected, the SSTable keeps its original `repairedAt` field, which denotes the time of the repair.

### Procedure

1. Before using `sstablescrub`, try rebuilding the tables using `nodetool scrub`.  
If `nodetool scrub` does not fix the problem, use this utility.
2. **Shut down the node.**



## 3. Run the utility:

- Package installations: `sstablescrib [options] <keyspace> <table>`
- Tarball installations: `install_location/bin/sstablescrib [options] <keyspace> <table>`

**Table 16: Options**

Flag	Option	Description
	<code>--debug</code>	Display stack traces.
<code>-h</code>	<code>--help</code>	Display help.
<code>-m</code>	<code>--manifest-check</code>	Only check and repair the leveled manifest, without actually scrubbing the SSTables.
<code>-s</code>	<code>--skip-corrupted</code>	Skip corrupt rows in counter tables.
<code>-v</code>	<code>--verbose</code>	Verbose output.

## The sstablesplit utility

Use this tool to split SSTables files into multiple SSTables of a maximum designated size.

### About this task

Use this tool to split SSTables files into multiple SSTables of a maximum designated size. For example, if `SizeTieredCompactionStrategy` was used for a major compaction and results in a excessively large SSTable, it's a good idea to split the table because won't get compacted again until the next huge compaction.

Cassandra must be stopped to use this tool:

- Package installations:

```
$ sudo service cassandra stop
```

- Tarball installations:

```
$ ps auwx | grep cassandra
$ sudo kill pid
```

Usage:

- Package installations: `sstablesplit [options] <filename> [<filename>]*`
- Tarball installations: `install_location/tools/bin/sstablesplit [options] <filename> [<filename>]*`

Example:

```
$ sstablesplit -s 40 /var/lib/cassandra/data/Keyspace1/Standard1/*
```

**Table 17: Options**

Flag	Option	Description
	<code>--debug</code>	Display stack traces.
<code>-h</code>	<code>--help</code>	Display help.
	<code>--no-snapshot</code>	Do not snapshot the SSTables before splitting.

Flag	Option	Description
-s	--size <size>	Maximum size in MB for the output SSTables (default: 50).
-v	--verbose	Verbose output.

## The sstablekeys utility

The sstablekeys utility dumps table keys.

### About this task

The sstablekeys utility dumps table keys. To list the keys in an SSTable, find the name of the SSTable file. The file is located in the data directory and has a `.db` extension. The location of the data directory, listed in the ["Install locations" section](#), depends on the type of installation. After finding the name of the file, use the name as an argument to the `sstablekeys` command.

```
$ bin/sstablekeys <sstable_name>
```

### Procedure

1. Create the playlists table in the music keyspace as shown in [Data modeling](#).
2. **Insert** the row of data about ZZ Top in playlists:

```
INSERT INTO music.playlists (id, song_order, song_id, title, artist,
album)
VALUES (62c36092-82a1-3a00-93d1-46196ee77204,
1,
a3e64f8f-bd44-4f28-b8d9-6938726e34d4,
'La Grange',
'ZZ Top',
'Tres Hombres');
```

3. Flush the data to disk.

```
$ nodetool flush music playlists
```

4. Look at keys in the SSTable data. For example, use `sstablekeys` followed by the path to the data. Use the path to data for your Cassandra installation:

```
$ sstablekeys <path to data>/data/data/music/
playlists-8b9f4cc0229211e4b02073ded3cb6170/music-playlists-ka-1-Data.db
```

The output appears, for example:

```
62c3609282a13a0093d146196ee77204
```

## The sstableupgrade tool

Upgrade the SSTables in the specified table or snapshot to match the currently installed version of Cassandra.

### About this task

This tool rewrites the SSTables in the specified table or snapshot to match the currently installed version of Cassandra.

If restoring with `sstableloader`, you must upgrade your snapshots before restoring for any snapshot taken in a major version older than the major version that Cassandra is currently running.

Usage:

- Package installations: `sstableupgrade [options] <keyspace> <cf> [snapshot]`
- Tarball installations: `install_location/bin/sstableupgrade [options] <keyspace> <cf> [snapshot]`

The snapshot option only upgrades the specified snapshot.

**Table 18: Options**

Flag	Option	Description
	--debug	Display stack traces.
-h	--help	Display help.

# References

Reference topics.

## Starting and stopping Cassandra

Topics for starting and stopping Cassandra.

### Starting Cassandra as a service

Start the Cassandra Java server process for packaged installations.

#### About this task

Start the Cassandra Java server process for packaged installations.

Startup scripts are provided in the `/etc/init.d` directory. The service runs as the `cassandra` user.

#### Procedure

You must have root or sudo permissions to start Cassandra as a service.

On initial start-up, each node must be started one at a time, starting with your seed nodes:

```
$ sudo service cassandra start
```

On Enterprise Linux systems, the Cassandra service runs as a java process.

### Starting Cassandra as a stand-alone process

Start the Cassandra Java server process for tarball installations.

#### About this task

Start the Cassandra Java server process for tarball installations.

#### Procedure

On initial start-up, each node must be started one at a time, starting with your seed nodes.

- To start Cassandra in the background:

```
$ cd install_location  
$ bin/cassandra
```

- To start Cassandra in the foreground:

```
$ cd install_location  
$ bin/cassandra -f
```

### Stopping Cassandra as a service

Stopping the Cassandra Java server process on packaged installations.

#### About this task

Stopping the Cassandra Java server process on packaged installations.

**Procedure**

You must have root or sudo permissions to stop the Cassandra service:

```
$ sudo service cassandra stop
```

**Stopping Cassandra as a stand-alone process**

Stop the Cassandra Java server process on tarball installations.

**About this task**

Stop the Cassandra Java server process on tarball installations.

**Procedure**

Find the Cassandra Java process ID (PID), and then kill the process using its PID number:

```
$ ps auwx | grep cassandra
$ sudo kill pid
```

**Clearing the data as a service**

Remove all data from a package installation. Special instructions for AMI restart.

**About this task**

Remove all data from a package installation.

**Procedure**

To clear the data from the **default** directories:

After **stopping** the service, run the following command:

```
$ sudo rm -rf /var/lib/cassandra/*
```

**Note:** If you are clearing data from an AMI installation for restart, you need to **preserve the log files**.

**Clearing the data as a stand-alone process**

Remove all data from a tarball installation.

**About this task**

Remove all data from a tarball installation.

**Procedure**

To clear all data from the **default** directories, including the commitlog and saved\_caches:

1. After **stopping** the process, run the following command from the install directory:

```
$ cd install_location
$ sudo rm -rf data/*
```

2. To clear the only the data directory:

```
$ cd install_location
$ sudo rm -rf data/data/*
```

## Install locations

Install location topics.

### Tarball installation directories

Configuration files directory locations.

The configuration files are located in the following directories:

Configuration Files	Locations
<code>cassandra.yaml</code>	<code>install_location/conf</code>
<code>cassandra-topology.properties</code>	<code>install_location/conf</code>
<code>cassandra-rackdc.properties</code>	<code>install_location/conf</code>
<code>cassandra-env.sh</code>	<code>install_location/conf</code>
<code>cassandra.in.sh</code>	<code>install_location/bin</code>

The binary tarball releases install into the installation directory.

Directories	Description
<code>data</code>	Files for commitlog, data, and saved_caches (unless set in <code>cassandra.yaml</code> )
<code>bin</code>	Utilities and start scripts
<code>conf</code>	Configuration files and environment settings
<code>interface</code>	Thrift and Avro client APIs
<code>javadoc</code>	Cassandra Java API documentation
<code>lib</code>	JAR and license files
<code>tools</code>	Cassandra tools and sample <code>cassandra.yaml</code> files for stress testing.

For DataStax Enterprise installs, see the documentation for your DataStax Enterprise version.

### Package installation directories

Configuration files directory locations.

The configuration files are located in the following directories:

Configuration Files	Locations
<code>cassandra.yaml</code>	<code>/etc/cassandra</code>
<code>cassandra-topology.properties</code>	<code>/etc/cassandra</code>
<code>cassandra-rackdc.properties</code>	<code>/etc/cassandra</code>
<code>cassandra-env.sh</code>	<code>/etc/cassandra</code>
<code>cassandra.in.sh</code>	<code>/usr/share/cassandra</code>

The packaged releases install into these directories:

Directories	Description
<code>/var/lib/cassandra</code>	Data directories
<code>/var/log/cassandra</code>	Log directory
<code>/var/run/cassandra</code>	Runtime files
<code>/usr/share/cassandra</code>	Environment settings
<code>/usr/share/cassandra/lib</code>	JAR files
<code>/usr/bin</code>	Optional utilities, such as <code>sstablelevelreset</code> , <code>sstable repairedset</code> , and <code>sstable split</code>
<code>/usr/bin</code>	Binary files
<code>/usr/sbin</code>	
<code>/etc/cassandra</code>	Configuration files
<code>/etc/init.d</code>	Service startup script
<code>/etc/security/limits.d</code>	Cassandra user limits
<code>/etc/default</code>	
<code>/usr/share/doc/cassandra/examples</code>	Sample <code>cassandra.yaml</code> files for stress testing.

For DataStax Enterprise installs, see the documentation for your DataStax Enterprise version.

## Cassandra include file

Set environment variables (`cassandra.in.sh`).

To set environment variables (Linux only), Cassandra can use an include file, `cassandra.in.sh`. This file is located in:

- Tarball installations: `install_location/bin/cassandra.in.sh`
- Package installations: `/usr/share/cassandra/cassandra.in.sh`

## Cassandra-CLI utility (deprecated)

Deprecated configuration attributes. Will be removed in Cassandra 3.0.

**Important:** The CLI utility is **deprecated** and will be removed in Cassandra 3.0. For ease of use and performance, switch from Thrift and CLI to **CQL** and `cqlsh`.

### Keyspace attributes

Cassandra stores storage configuration attributes in the system keyspace. You can set storage engine configuration attributes on a per-keyspace or per-table basis on the command line using the Cassandra-CLI utility. A keyspace must have a user-defined name, a replica placement strategy, and options that specify the number of copies per data center or node.

## References

### name

Required. The name for the keyspace.

### placement\_strategy

Required. Determines how Cassandra distributes replicas for a keyspace among nodes in the ring. Values are:

- `SimpleStrategy` or `org.apache.cassandra.locator.SimpleStrategy`
- `NetworkTopologyStrategy` or `org.apache.cassandra.locator.NetworkTopologyStrategy`

`NetworkTopologyStrategy` requires a [snitch](#) to be able to determine rack and data center locations of a node. For more information about replication placement strategy, see [Data replication](#).

### strategy\_options

Specifies configuration options for the chosen replication strategy class. The replication factor option is the total number of replicas across the cluster. A replication factor of 1 means that there is only one copy of each row on one node. A replication factor of 2 means there are two copies of each row, where each copy is on a different node. All replicas are equally important; there is no primary or master replica. As a general rule, the replication factor should not exceed the number of nodes in the cluster. However, you can increase the replication factor and then add the desired number of nodes.

When the replication factor exceeds the number of nodes, writes are rejected, but reads are served as long as the desired consistency level can be met.

For more information about configuring the replication placement strategy for a cluster and data centers, see [Choosing keyspace replication options](#).

### durable\_writes

(Default: true) When set to false, data written to the keyspace bypasses the commit log. Be careful using this option because you risk losing data.

## Table attributes

Attributes per table.

The following attributes can be declared per table.

### bloom\_filter\_fp\_chance

See [CQL properties](#) in *CQL for Cassandra 2.x*.

### bucket\_high

See [CQL Compaction Subproperties](#) in *CQL for Cassandra 2.x*.

### bucket\_low

See [CQL Compaction Subproperties](#) in *CQL for Cassandra 2.x*.

### caching

See [CQL properties](#) in *CQL for Cassandra 2.x*.

### chunk\_length\_kb

See [CQL Compression Subproperties](#) in *CQL for Cassandra 2.x*.

### column\_metadata

(Default: N/A - container attribute) Column metadata defines these attributes of a column:

- `name`: Binds a `validation_class` and (optionally) an index to a column.
- `validation_class`: Type used to check the column value.
- `index_name`: Name of the index.
- `index_type`: Type of index. Currently the only supported value is KEYS.



Setting a value for the name option is required. The `validation_class` is set to the `default_validation_class` of the table if you do not set the `validation_class` option explicitly. The value of `index_type` must be set to create an index for a column. The value of `index_name` is not valid unless `index_type` is also set.

Setting and updating column metadata with the Cassandra-CLI utility requires a slightly different command syntax than other attributes; note the brackets and curly braces in this example:

```
[default@demo ] UPDATE COLUMN FAMILY users WITH comparator =UTF8Type
AND column_metadata =[{column_name: full_name, validation_class: UTF8Type,
index_type: KEYS }];
```

### column\_type

(Default: Standard) The standard type of table contains regular columns.

### comment

See [CQL properties](#) in *CQL for Cassandra 2.x*.

### compaction\_strategy

See `compaction` in [CQL properties](#) in *CQL for Cassandra 2.x*.

### compaction\_strategy\_options

(Default: N/A - container attribute) Sets attributes related to the chosen compaction-strategy. Attributes are:

- [bucket\\_high](#)
- [bucket\\_low](#)
- [max\\_compaction\\_threshold](#)
- [min\\_compaction\\_threshold](#)
- [min\\_sstable\\_size](#)
- [sstable\\_size\\_in\\_mb](#)
- [tombstone\\_compaction\\_interval](#)
- [tombstone\\_threshold](#)

### comparator

(Default: BytesType) Defines the data types used to validate and sort column names. There are several built-in column comparators available. The comparator cannot be changed after you create a table.

### compression\_options

(Default: N/A - container attribute) Sets the compression algorithm and sub-properties for the table. Choices are:

- [sstable\\_compression](#)
- [chunk\\_length\\_kb](#)
- [crc\\_check\\_chance](#)

### crc\_check\_chance

See [CQLCompression Subproperties](#) in *CQL for Cassandra 2.x*.

### default\_time\_to\_live

See [CQL properties](#) in *CQL for Cassandra 2.x*.

### default\_validation\_class

(Default: N/A) Defines the data type used to validate column values. There are several built-in column validators available.

### gc\_grace

See [CQL properties](#) in *CQL for Cassandra 2.x*.

### index\_interval

See [CQL properties](#) in *CQL for Cassandra 2.x*.

### key\_validation\_class

## References

(Default: N/A) Defines the data type used to validate row key values. There are several built-in key validators available, however `CounterColumnType` (distributed counters) cannot be used as a row key validator.

### **max\_compaction\_threshold**

See `max_threshold` in [CQL Compaction Subproperties](#) in *CQL for Cassandra 2.x*.

### **min\_compaction\_threshold**

See `min_threshold` in [CQL Compaction Subproperties](#) in *CQL for Cassandra 2.x*.

### **max\_index\_interval**

See [CQL properties](#) in *CQL for Cassandra 2.x*.

### **min\_index\_interval**

See [CQL properties](#) in *CQL for Cassandra 2.x*.

### **memtable\_flush\_after\_mins**

Deprecated as of Cassandra 1.0, but can still be declared for backward compatibility. Use [commitlog\\_total\\_space\\_in\\_mb](#).

### **memtable\_flush\_period\_in\_ms**

See [CQL properties](#) in *CQL for Cassandra 2.x*.

### **memtable\_operations\_in\_millions**

Deprecated as of Cassandra 1.0, but can still be declared for backward compatibility. Use [commitlog\\_total\\_space\\_in\\_mb](#).

### **memtable\_throughput\_in\_mb**

Deprecated as of Cassandra 1.0, but can still be declared for backward compatibility. Use [commitlog\\_total\\_space\\_in\\_mb](#).

### **min\_sstable\_size**

See [CQL Compaction Subproperties](#) in *CQL for Cassandra 2.x*.

### **name**

(Default: N/A) Required. The user-defined name of the table.

### **read\_repair\_chance**

See [CQL properties](#) in *CQL for Cassandra 2.x*.

### **speculative\_retry**

See [CQL properties](#) in *CQL for Cassandra 2.x*.

### **sstable\_size\_in\_mb**

See [CQL Compaction Subproperties](#) in *CQL for Cassandra 2.x*.

### **sstable\_compression**

See `compression` in [CQL properties](#) in *CQL for Cassandra 2.x*.

### **tombstone\_compaction\_interval**

See [CQL Compaction Subproperties](#) in *CQL for Cassandra 2.x*.

### **tombstone\_threshold**

See [CQL Compaction Subproperties](#) in *CQL for Cassandra 2.x*.

## Moving data to or from other databases

Solutions for migrating from other databases.

Cassandra offers several solutions for migrating from other databases:

- The **COPY command**, which mirrors what the PostgreSQL RDBMS uses for file/export import.
- The **Cassandra bulk loader** provides the ability to bulk load external data into a cluster.

### About the COPY command

You can use COPY in Cassandra's CQL shell to load flat file data into Cassandra (nearly all RDBMS's have unload utilities that allow table data to be written to OS files) as well as data to be written out to OS files.

### ETL Tools

If you need more sophistication applied to a data movement situation (more than just extract-load), then you can use any number of extract-transform-load (ETL) solutions that now support Cassandra. These tools provide excellent transformation routines that allow you to manipulate source data in literally any way you need and then load it into a Cassandra target. They also supply many other features such as visual, point-and-click interfaces, scheduling engines, and more.

Many ETL vendors who support Cassandra supply community editions of their products that are free and able to solve many different use cases. Enterprise editions are also available that supply many other compelling features that serious enterprise data users need.

You can freely download and try ETL tools from Jaspersoft, Pentaho, and Talend that all work with community Cassandra.

## Troubleshooting

### Peculiar Linux kernel performance problem on NUMA systems

Problems due to `zone_reclaim_mode`.

Problems due to `zone_reclaim_mode`.

The Linux kernel can be inconsistent in enabling/disabling `zone_reclaim_mode`. This can result in odd performance problems:

- Random huge CPU spikes resulting in large increases in latency and throughput.
- Programs hanging indefinitely apparently doing nothing.
- Symptoms appearing and disappearing suddenly.
- After a reboot, the symptoms generally do not show again for some time.

To ensure that `zone_reclaim_mode` is disabled:

```
$ echo 0 > /proc/sys/vm/zone_reclaim_mode
```

### Reads are getting slower while writes are still fast

The cluster's IO capacity is not enough to handle the write load it is receiving.

The cluster's IO capacity is not enough to handle the write load it is receiving.

Check the SSTable counts in `cfstats`. If the count is continually growing, the cluster's IO capacity is not enough to handle the write load it is receiving. Reads have slowed down because the data is fragmented across many SSTables and compaction is continually running trying to reduce them. Adding more IO capacity, either via more machines in the cluster, or faster drives such as SSDs, will be necessary to solve this.

If the SSTable count is relatively low (32 or less) then the amount of file cache available per machine compared to the amount of data per machine needs to be considered, as well as the application's read pattern. The amount of file cache can be formulated as  $(TotalMemory - JVMHeapSize)$  and if the amount of data is greater and the read pattern is approximately random, an equal ratio of reads to the cache:data ratio will need to seek the disk. With spinning media, this is a slow operation. You may be able to mitigate many of the seeks by using a key cache of 100%, and a small amount of row cache (10000-20000) if you have some hot rows and they are not extremely large.

### Nodes seem to freeze after some period of time

Some portion of the JVM is being swapped out by the operating system (OS).

Some portion of the JVM is being swapped out by the operating system (OS).

Check your `system.log` for messages from the `GCInspector`. If the `GCInspector` is indicating that either the `ParNew` or `ConcurrentMarkSweep` collectors took longer than 15 seconds, there is a high probability that some portion of the JVM is being swapped out by the OS.

One way this might happen is if the `mmap DiskAccessMode` is used without JNA support. The address space will be exhausted by `mmap`, and the OS will decide to swap out some portion of the JVM that isn't in use, but eventually the JVM will try to GC this space. Adding the JNA libraries will solve this (they cannot be shipped with Cassandra due to carrying a GPL license, but are freely available) or the

`DiskAccessMode` can be switched to `mmap_index_only`, which as the name implies will only `mmap` the indices, using much less address space.

DataStax strongly recommends that you disable swap entirely (`sudo swapoff --all`). Because Cassandra has multiple replicas and transparent failover, it is preferable for a replica to be killed immediately when memory is low rather than go into swap. This allows traffic to be immediately redirected to a functioning replica instead of continuing to hit the replica that has high latency due to swapping. If your system has a lot of DRAM, swapping still lowers performance significantly because the OS swaps out executable code so that more DRAM is available for caching disks. To make this change permanent, remove all swap file entries from `/etc/fstab`.

If you insist on using swap, you can set `vm.swappiness=1`. This allows the kernel swap out the absolute least used parts.

If the GCInspector isn't reporting very long GC times, but is reporting moderate times frequently (`ConcurrentMarkSweep` taking a few seconds very often) then it is likely that the JVM is experiencing extreme GC pressure and will eventually OOM. See the section below on OOM errors.

## Nodes are dying with OOM errors

Nodes are dying with `OutOfMemory` exceptions.

Nodes are dying with `OutOfMemory` exceptions.

Check for these typical causes:

### Row cache is too large, or is caching large rows

Row cache is generally a high-end optimization. Try disabling it and see if the OOM problems continue.

### The memtable sizes are too large for the amount of heap allocated to the JVM

You can expect  $N + 2$  memtables resident in memory, where  $N$  is the number of tables. Adding another 1GB on top of that for Cassandra itself is a good estimate of total heap usage.

If none of these seem to apply to your situation, try loading the heap dump in **MAT** and see which class is consuming the bulk of the heap for clues.

## Nodetool or JMX connections failing on remote nodes

Nodetool commands can be run locally but not on other nodes in the cluster.

Nodetool commands can be run locally but not on other nodes in the cluster.

If you can run nodetool commands locally but not on other nodes in the ring, you may have a common JMX connection problem that is resolved by adding an entry like the following in `install_location/conf/cassandra-env.sh` on each node:

```
JVM_OPTS = "$JVM_OPTS -Djava.rmi.server.hostname=<public name>"
```

If you still cannot run nodetool commands remotely after making this configuration change, do a full evaluation of your firewall and network security. The nodetool utility communicates through JMX on port 7199.

## Handling schema disagreements

Check for and resolve schema disagreements.

Check for and resolve schema disagreements.

## Troubleshooting

### About this task

In the event that a schema disagreement occurs, check for and resolve schema disagreements as follows:

### Procedure

1. Run the `nodetool describecluster` command.

```
$ bin/nodetool describecluster
```

If any node is UNREACHABLE, you see output something like this:

```
$ bin/nodetool describecluster
Snitch: org.apache.cassandra.locator.DynamicEndpointSnitch
Partitioner: org.apache.cassandra.dht.Murmur3Partitioner
Schema versions:
  UNREACHABLE: 1176b7ac-8993-395d-85fd-41b89ef49fbb: [10.202.205.203]
                9b861925-1a19-057c-ff70-779273e95aa6: [10.80.207.102]
                8613985e-c49e-b8f7-57ae-6439e879bb2a: [10.116.138.23]
```

2. Restart unreachable nodes.
3. Repeat steps 1 and 2 until `nodetool describecluster` shows that all nodes have the same schema version number#only one schema version appears in the output.

## View of ring differs between some nodes

Indicates that the ring is in a bad state.

Indicates that the ring is in a bad state.

This situation can happen when not using virtual nodes (vnodes) and there are token conflicts (for instance, when bootstrapping two nodes simultaneously with automatic token selection.) Unfortunately, the only way to resolve this is to do a full cluster restart. A rolling restart is insufficient since gossip from nodes with the bad state will repopulate it on newly booted nodes.

## Java reports an error saying there are too many open files

Java may not have open enough file descriptors.

Java may not have open enough file descriptors.

Cassandra generally needs more than the default (1024) amount of file descriptors. To increase the number of file descriptors, change the security limits on your Cassandra nodes as described in the [Recommended Settings](#) section of [Insufficient user resource limits errors](#).

Another, much less likely possibility, is a file descriptor leak in Cassandra. Run `lsuf -n | grep java` to check that the number of file descriptors opened by Java is reasonable and reports the error if the number is greater than a few thousand.

## Insufficient user resource limits errors

Insufficient resource limits may result in a number of errors in Cassandra and OpsCenter.

Insufficient resource limits may result in a number of errors in Cassandra and OpsCenter.

### Cassandra errors

Insufficient as (address space) or memlock setting

```

ERROR      [SSTableBatchOpen:1      ]      2012-07-25      15:46:02,913
AbstractCassandraDaemon.java (line 139)
Fatal exception in thread Thread [SSTableBatchOpen:1,5,main ]
java.io.IOException: java.io.IOException: Map failed at ...

```

### Insufficient memlock settings

```

WARN [main ] 2011-06-15 09:58:56,861 CLibrary.java (line 118) Unable to lock
JVM memory (ENOMEM).
This can result in part of the JVM being swapped out, especially with mmaped
I/O enabled.
Increase RLIMIT_MEMLOCK or run Cassandra as root.

```

### Insufficient nofiles setting

```

WARN 05:13:43,644 Transport error occurred during acceptance of message.
org.apache.thrift.transport.TTransportException: java.net.SocketException:
Too many open files ...

```

### Insufficient nofiles setting

```

ERROR [MutationStage:11 ] 2012-04-30 09:46:08,102 AbstractCassandraDaemon.java
(line 139)
Fatal exception in thread Thread [MutationStage:11,5,main ]
java.lang.OutOfMemoryError: unable to create new native thread

```

## Recommended settings

You can view the current limits using the `ulimit -a` command. Although limits can also be temporarily set using this command, DataStax recommends making the changes permanent:

Packaged installs: Ensure that the following settings are included in the `/etc/security/limits.d/cassandra.conf` file:

```

cassandra - memlock unlimited
cassandra - nofile 100000
cassandra - nproc 32768
cassandra - as unlimited

```

Tarball installs: Ensure that the following settings are included in the `/etc/security/limits.conf` file:

```

* - memlock unlimited
* - nofile 100000
* - nproc 32768
* - as unlimited

```

If you run Cassandra as root, some Linux distributions such as Ubuntu, require setting the limits for root explicitly instead of using `*`:

```

root - memlock unlimited
root - nofile 100000
root - nproc 32768
root - as unlimited

```

For CentOS, RHEL, OEL systems, also set the nproc limits in `/etc/security/limits.d/90-nproc.conf`:

```

* - nproc 32768

```

For all installations, add the following line to `/etc/sysctl.conf`:

```

vm.max_map_count = 131072

```

## Troubleshooting

To make the changes take effect, reboot the server or run the following command:

```
$ sudo sysctl -p
```

To confirm the limits are applied to the Cassandra process, run the following command where *pid* is the process ID of the currently running Cassandra process:

```
$ cat /proc/<pid>/limits
```

### OpsCenter errors

See the [OpsCenter Troubleshooting](#) documentation.

## Cannot initialize class org.xerial.snappy.Snappy

An error may occur when Snappy compression/decompression is enabled although its library is available from the classpath.

An error may occur when Snappy compression/decompression is enabled although its library is available from the classpath.

```
java.util.concurrent.ExecutionException: java.lang.NoClassDefFoundError:
    Could not initialize class org.xerial.snappy.Snappy
...
Caused by: java.lang.NoClassDefFoundError: Could not initialize class
    org.xerial.snappy.Snappy
    at
    org.apache.cassandra.io.compress.SnappyCompressor.initialCompressedBufferLength
    (SnappyCompressor.java:39)
```

The native library `snappy-1.0.4.1-libsnapappyjava.so` for Snappy compression is included in the `snappy-java-1.0.4.1.jar` file. When the JVM initializes the JAR, the library is added to the default temp directory. If the default temp directory is mounted with a `noexec` option, it results in the above exception.

One solution is to specify a different temp directory that has already been mounted without the `noexec` option, as follows:

- If you use the DSE/Cassandra command `$_BIN/dse cassandra` or `$_BIN/cassandra`, simply append the command line:
  - DSE: `bin/dse cassandra -t -Dorg.xerial.snappy.tempdir=/path/to/newtmp`
  - Cassandra: `bin/cassandra -Dorg.xerial.snappy.tempdir=/path/to/newtmp`
- If starting from a package using `service dse start` or `service cassandra start`, add a system environment variable `JVM_OPTS` with the value:

```
JVM_OPTS=-Dorg.xerial.snappy.tempdir=/path/to/newtmp
```

The default `cassandra-env.sh` looks for the variable and appends to it when starting the JVM.

## Firewall idle connection timeout causing nodes to lose communication during low traffic times

Steps to configure the default idle connection timeout.

### About this task

During low traffic intervals, a firewall configured with an idle connection timeout can close connections to local nodes and nodes in other data centers. The default idle connection timeout is usually 60 minutes and configurable by the network administrator.



## Procedure

To prevent connections between nodes from timing out, set the TCP keep alive variables:

1. Get a list of available kernel variables:

```
$ sysctl -A | grep net.ipv4
```

The following variables should exist:

- *net.ipv4.tcp\_keepalive\_time*  
Time of connection inactivity after which the first keep alive request is sent.
- *net.ipv4.tcp\_keepalive\_probes*  
Number of keep alive requests retransmitted before the connection is considered broken.
- *net.ipv4.tcp\_keepalive\_intvl*  
Time interval between keep alive probes.

2. To change these settings:

```
$ sudo sysctl -w net.ipv4.tcp_keepalive_time=60  
net.ipv4.tcp_keepalive_probes=3 net.ipv4.tcp_keepalive_intvl=10
```

This sample command changes TCP keepalive timeout to 60 seconds with 3 probes, 10 seconds gap between each. This setting detects dead TCP connections after 90 seconds (60 + 10 + 10 + 10). There is no need to be concerned about the additional traffic as it's negligible and permanently leaving these settings shouldn't be an issue.

## DataStax Community release notes

Release notes for DataStax Community.

The latest Cassandra version is 2.1.5. The `CHANGES.txt` file installed with Cassandra covers changes in detail. An important changes to note is that incremental replacement of compacted SSTables has been disabled for this release. This was done to prevent problems until the entire compaction chain of events is stabilized.

**Key features** of Cassandra 2.1 were described earlier in this document. Noteworthy changes for Cassandra 2.1 include:

- Cassandra 2.1 does not support pre-Cassandra 2.0 SSTables.
  - To upgrade to Cassandra 2.1 from a previous release that stored data in Cassandra 1.2.x SSTables, start the node on Cassandra 2.0 and use the `sstableupgrade` tool after upgrading. Upgrade SSTables even if you do not perform a rolling upgrade. Resolve schema disagreements if any exist, and restart each node. For more upgrade information, see "[Upgrading Cassandra](#)" and `NEWS.txt`.
- The shuffle utility for migrating to virtual nodes (vnodes) and the `nodetool taketoken` command have been removed. To migrate to vnodes, [bootstrap a new data center](#).
- Cassandra 2.1 bundles and enables JNA. If JNA fails to initialize, you can disable JNA by using the `-Dcassandra.boot_without_jna=true` option to start Cassandra.
- Cassandra rejects `USING TIMESTAMP` or `USING TTL` in the command to update a counter column, and now generates an error message when you attempt such an operation.
- Configurable properties have been added to manage counter writes.
- A configurable counter cache reduces lock contention and helps with concurrency.
- In Cassandra 2.1, the CQL table property `index_interval` is replaced by `min_index_interval` and `max_index_interval`. The `max_index_interval` is 2048 by default. The default would be reached only when SSTables are infrequently-read and the index summary memory pool is full. When upgrading from earlier releases, Cassandra uses the old `index_interval` value for the `min_index_interval`.
- CASSANDRA-6504 has been backported to Cassandra 2.0.5 so you can perform a rolling upgrade of a database having counters to Cassandra 2.1.
- Default data and log locations have changed for tarball installations and source checkouts. By default, the data file directory, commitlog directory, and saved caches directory are in `$CASSANDRA_HOME/data/data`, `$CASSANDRA_HOME/data/commitlog`, and `$CASSANDRA_HOME/data/saved_caches`, respectively. The log directory now defaults to `$CASSANDRA_HOME/logs`. If not set, `$CASSANDRA_HOME`, defaults to the top-level directory of the installation. Deb and RPM packages continue to use `/var/lib/cassandra` and `/var/log/cassandra` by default.
- Cassandra 2.1 maintains data consistency during bootstrapping. As you [bootstrap](#) a new node, Cassandra streams the data for the new node from an existing node that is free from [range movement](#). If data inconsistency issues are present in the cluster, the improvement to bootstrapping handles these issues. Data inconsistency commonly occurs after frequent data deletions and a node going down.
- To inhibit the new Cassandra 2.1 bootstrapping behavior, and make Cassandra 2.0 behavior effective, start the node using the `-Dcassandra.consistent.rangemovement=false` property:
  - Package installations: Add the following option to `/usr/share/cassandra/cassandra-env.sh` file:
 

```
JVM_OPTS="$JVM_OPTS -Dcassandra.consistent.rangemovement=false
```

- Tarball installations: Start Cassandra with this option:

```
$ bin/cassandra -Dcassandra.consistent.rangemovement=false
```

To replace a dead node, you also need to [specify the address](#) of the node from which Cassandra streams the data.



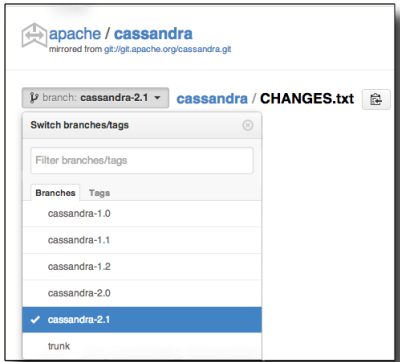





For a complete list of fixes and new features, see the Apache Cassandra 2.1.0 [CHANGES.txt](#). You can view all version changes by branch or tag in the **branch** drop-down list:



## Tips for using DataStax documentation

### Navigating the documents

To navigate, use the table of contents or search in the left navigation bar. Additional controls are:

	Hide or display the left navigation.
	Go back or forward through the topics as listed in the table of contents.
	Toggle highlighting of search terms.
	Print page.
	See doc tweets and provide feedback.
	Grab to adjust the size of the navigation pane.
	Appears on headings for bookmarking. Right-click the  to get the link.
	Toggles the legend for CQL statements and nodetool options.

### Other resources

You can find more information and help at:

- [Documentation home page](#)
- [Datasheets](#)
- [Webinars](#)
- [Whitepapers](#)
- [Developer blogs](#)
- [Support](#)