



# Artix™

---

Artix for CORBA  
Version 4.1, September 2006

IONA Technologies PLC and/or its subsidiaries may have patents, patent applications, trademarks, copyrights, or other intellectual property rights covering subject matter in this publication. Except as expressly provided in any written license agreement from IONA Technologies PLC, the furnishing of this publication does not give you any license to these patents, trademarks, copyrights, or other intellectual property. Any rights not expressly granted herein are reserved.

IONA, IONA Technologies, the IONA logo, Orbix, Orbix Mainframe, Orbix Connect, Artix, Artix Mainframe, Artix Mainframe Developer, Mobile Orchestrator, Orbix/E, Orbacus, Enterprise Integrator, Adaptive Runtime Technology, and Making Software Work Together are trademarks or registered trademarks of IONA Technologies PLC and/or its subsidiaries.

Java and J2EE are trademarks or registered trademarks of Sun Microsystems, Inc. in the United States and other countries. CORBA is a trademark or registered trademark of the Object Management Group, Inc. in the United States and other countries. All other trademarks that appear herein are the property of their respective owners.

While the information in this publication is believed to be accurate, IONA Technologies PLC makes no warranty of any kind to this material including, but not limited to, the implied warranties of merchantability and fitness for a particular purpose. IONA shall not be liable for errors contained herein, or for incidental or consequential damages in connection with the furnishing, performance or use of this material.

---

#### COPYRIGHT NOTICE

No part of this publication may be reproduced, stored in a retrieval system or transmitted, in any form or by any means, photocopying, recording or otherwise, without prior written consent of IONA Technologies PLC. No third-party intellectual property right liability is assumed with respect to the use of the information contained herein. IONA Technologies PLC assumes no responsibility for errors or omissions contained in this publication. This publication and features described herein are subject to change without notice.

Copyright © 1999-2006 IONA Technologies PLC. All rights reserved.

All products or services mentioned in this publication are covered by the trademarks, service marks, or product names as designated by the companies that market those products.

Updated: September 27, 2006

# Contents

<b>List of Figures</b>	<b>7</b>
<b>Preface</b>	<b>9</b>
<b>Chapter 1 Introduction to CORBA Web Services</b>	<b>17</b>
<b>Artix Architecture</b>	<b>18</b>
<b>Integrating a CORBA Server with Web Services</b>	<b>22</b>
Accessing the CORBA Server through a Standalone Router	<b>23</b>
Accessing the CORBA Server through an Embedded Router	<b>24</b>
Replacing the WS Client by an Artix Client	<b>25</b>
Replacing the CORBA Server by an Artix Server	<b>26</b>
<b>Integrating a CORBA Client with Web Services</b>	<b>27</b>
Accessing the WS Server through a Standalone Router	<b>28</b>
Replacing the CORBA Client by an Artix Client	<b>29</b>
Replacing the WS Server by an Artix Server	<b>30</b>
<b>Chapter 2 Exposing a Web Service as a CORBA Service</b>	<b>31</b>
<b>Converting WSDL to IDL</b>	<b>32</b>
<b>Exposing an Artix Web Service as a CORBA Service</b>	<b>35</b>
<b>Exposing a Non-Artix Web Service as a CORBA Service</b>	<b>39</b>
Standalone CORBA-to-SOAP Router Scenario	<b>40</b>
Configuring and Running a Standalone CORBA-to-SOAP Router	<b>41</b>
<b>Using an Orbix 3.3 Client to Access an Artix Server</b>	<b>47</b>
<b>High Performance Java CORBA Binding</b>	<b>50</b>
<b>Chapter 3 Exposing a CORBA Service as a Web Service</b>	<b>51</b>
<b>Converting IDL to WSDL</b>	<b>52</b>
<b>Embedding Artix in a CORBA Service</b>	<b>61</b>
Embedded Router Scenario	<b>62</b>
Embedding a Router in the CORBA Server	<b>64</b>
<b>Exposing an Orbix 3.3 or Non-Orbix Service as a Web Service</b>	<b>68</b>
Standalone SOAP-to-CORBA Router Scenario	<b>69</b>
Configuring and Running a Standalone SOAP-to-CORBA Router	<b>71</b>

<b>Chapter 4 CORBA-to-CORBA Routing</b>	<b>75</b>
<b>Bypassing the Router</b>	<b>76</b>
Basic Bypass Scenario	77
Bypass with Failover Scenario	81
Bypass with Load Balancing Scenario	84
<b>Chapter 5 Integrating the CORBA Naming Service with Artix</b>	<b>87</b>
How an Artix Client Resolves a Name	88
How an Artix Server Binds a Name	92
Artix Client Integrated with a CORBA Server	95
CORBA Server Implementation	96
Artix Client Configuration	99
<b>Chapter 6 Advanced CORBA Port Configuration</b>	<b>101</b>
Configuring Fixed Ports and Long-Lived IORs	102
CORBA Timeout Policies	108
Retrying Invocations and Rebinding	110
<b>Chapter 7 Artix IDL-to-WSDL Mapping</b>	<b>113</b>
Introducing CORBA Type Mapping	114
IDL Primitive Type Mapping	115
IDL Complex Type Mapping	119
IDL enum Type	120
IDL struct Type	122
IDL union Type	124
IDL sequence Types	128
IDL array Types	130
IDL exception Types	132
IDL typedef Expressions	135
IDL Module and Interface Mapping	136
<b>Chapter 8 Artix WSDL-to-IDL Mapping</b>	<b>141</b>
Simple Types	142
Atomic Types	143
String Type	146
Date and Time Types	149
Duration Type	151

Deriving Simple Types by Restriction	152
List Type	154
Unsupported Simple Types	156
<b>Complex Types</b>	157
Sequence Complex Types	158
Choice Complex Types	159
All Complex Types	160
Attributes	161
Nesting Complex Types	163
Deriving a Complex Type from a Simple Type	165
Deriving a Complex Type from a Complex Type	167
Arrays	170
<b>Wildcarding Types</b>	173
<b>Occurrence Constraints</b>	174
<b>Nullable Types</b>	176
<b>Recursive Types</b>	179
<b>Endpoint References</b>	182
Default Endpoint Reference Mapping	183
Custom Endpoint Reference Mapping	188
<b>Mapping to IDL Modules</b>	195
<b>Chapter 9 Monitoring GIOP Message Content</b>	199
Introduction to GIOP Snoop	200
Configuring GIOP Snoop	201
GIOP Snoop Output	204
<b>Appendix A Configuring a CORBA Binding</b>	209
<b>Appendix B Configuring a CORBA Port</b>	215
<b>Appendix C CORBA Utilities in Artix</b>	221
Generating a CORBA Binding	222
Converting WSDL to OMG IDL	223
Converting OMG IDL to WSDL	224
<b>Appendix D Mapping CORBA Exceptions</b>	229
Mapping from CORBA System Exceptions	230

CONTENTS

<b>Mapping from Fault Categories</b>	<b>232</b>
<b>Mapping of Completion Status</b>	<b>233</b>
<b>Index</b>	<b>235</b>

# List of Figures

Figure 1: Artix Application with Multiple Bindings and Transports	18
Figure 2: Example of a SOAP/HTTP-to-CORBA Router	20
Figure 3: WS Client Accesses CORBA Server through Standalone Router	23
Figure 4: WS Client Accesses CORBA Server through Embedded Router	24
Figure 5: Replacing the WS Client by an Artix Client	25
Figure 6: Replacing the CORBA Server by an Artix Server	26
Figure 7: Client Accesses the WS Server through a Standalone Router	28
Figure 8: Replacing the CORBA Client by an Artix Client	29
Figure 9: Replacing the WS Server by an Artix Server	30
Figure 10: Standalone Artix Router	40
Figure 11: Artix Router Embedded in a CORBA Server	62
Figure 12: Standalone Artix Router	69
Figure 13: Basic Bypass Routing Scenario	77
Figure 14: Bypass Routing with Failover Scenario	81
Figure 15: Bypass Routing with Load Balancing Scenario	84
Figure 16: Artix Client Resolving a Name from the Naming Service	88
Figure 17: Artix Server Binding a Name to the Naming Service	92
Figure 18: Allowed Inheritance Relationships for Complex Types	167

## LIST OF FIGURES



# Preface

## What is Covered in This Book

This book describes a variety of different CORBA integration scenarios and explains how to use the Artix command-line tools to generate or modify WSDL contracts and IDL interfaces as required. Details of Artix programming, however, do not fall within the scope of this book.

## Who Should Read This Book

This book is aimed at engineers already familiar with CORBA technology who need to integrate Web services applications with CORBA.

## The Artix Library

The Artix documentation library is organized in the following sections:

- [Getting Started](#)
- [Designing Artix Solutions](#)
- [Configuring and Managing Artix Solutions](#)
- [Using Artix Services](#)
- [Integrating Artix Solutions](#)
- [Integrating with Management Systems](#)
- [Reference](#)
- [Artix Orchestration](#)

## Getting Started

The books in this section provide you with a background for working with Artix. They describe many of the concepts and technologies used by Artix. They include:

- [Release Notes](#) contains release-specific information about Artix.

- [Installation Guide](#) describes the prerequisites for installing Artix and the procedures for installing Artix on supported systems.
- [Getting Started with Artix](#) describes basic Artix and WSDL concepts.
- [Using Artix Designer](#) describes how to use Artix Designer to build Artix solutions.
- [Artix Technical Use Cases](#) provides a number of step-by-step examples of building common Artix solutions.

### **Designing Artix Solutions**

The books in this section go into greater depth about using Artix to solve real-world problems. They describe how to build service-oriented architectures with Artix and how Artix uses WSDL to define services:

- [Building Service-Oriented Infrastructures with Artix](#) provides an overview of service-oriented architectures and describes how they can be implemented using Artix.
- [Writing Artix Contracts](#) describes the components of an Artix contract. Special attention is paid to the WSDL extensions used to define Artix-specific payload formats and transports.

### **Developing Artix Solutions**

The books in this section how to use the Artix APIs to build new services:

- [Developing Artix Applications in C++](#) discusses the technical aspects of programming applications using the C++ API.
- [Developing Advanced Artix Plug-ins in C++](#) discusses the technical aspects of implementing advanced plug-ins (for example, interceptors) using the C++ API.
- [Developing Artix Applications in Java](#) discusses the technical aspects of programming applications using the Java API.

### **Configuring and Managing Artix Solutions**

This section includes:

- [Configuring and Managing Artix Solutions](#) explains how to set up your Artix environment and how to configure and deploy Artix services.
- [Managing Artix Solutions with JMX](#) explains how to monitor and manage an Artix runtime using Java Management Extensions.

### Using Artix Services

The books in this section describe how to use the services provided with Artix:

- [Artix Router Guide](#) explains how to integrate services using the Artix router.
- [Artix Locator Guide](#) explains how clients can find services using the Artix locator.
- [Artix Session Manager Guide](#) explains how to manage client sessions using the Artix session manager.
- [Artix Transactions Guide, C++](#) explains how to enable Artix C++ applications to participate in transacted operations.
- [Artix Transactions Guide, Java](#) explains how to enable Artix Java applications to participate in transacted operations.
- [Artix Security Guide](#) explains how to use the security features in Artix.

### Integrating Artix Solutions

The books in this section describe how to integrate Artix solutions with other middleware technologies.

- [Artix for CORBA](#) provides information on using Artix in a CORBA environment.
- [Artix for J2EE](#) provides information on using Artix to integrate with J2EE applications.

For details on integrating with Microsoft's .NET technology, see the documentation for Artix Connect.

### Integrating with Management Systems

The books in this section describe how to integrate Artix solutions with a range of enterprise and SOA management systems. They include:

- [IBM Tivoli Integration Guide](#) explains how to integrate Artix with the IBM Tivoli enterprise management system.
- [BMC Patrol Integration Guide](#) explains how to integrate Artix with the BMC Patrol enterprise management system.
- [CA-WSDM Integration Guide](#) explains how to integrate Artix with the CA-WSDM SOA management system.
- [AmberPoint Integration Guide](#) explains how to integrate Artix with the AmberPoint SOA management system.

### Reference

These books provide detailed reference information about specific Artix APIs, WSDL extensions, configuration variables, command-line tools, and terms. The reference documentation includes:

- [Artix Command Line Reference](#)
- [Artix Configuration Reference](#)
- [Artix WSDL Extension Reference](#)
- [Artix Java API Reference](#)
- [Artix C++ API Reference](#)
- [Artix .NET API Reference](#)
- [Artix Glossary](#)

### Artix Orchestration

These books describe the Artix support for Business Execution Process Language (BEPL), which is available as an add-on to Artix. These books include:

- [Artix Orchestration Release Notes](#)
- [Artix Orchestration Installation Guide](#)
- [Understanding Artix Orchestration](#)
- [Artix Orchestration Administration Console Help](#).

### Getting the Latest Version

The latest updates to the Artix documentation can be found at <http://www.iona.com/support/docs>.

Compare the version dates on the web page for your product version with the date printed on the copyright page of the PDF edition of the book you are reading.

### Searching the Artix Library

You can search the online documentation by using the **Search** box at the top right of the documentation home page:

<http://www.iona.com/support/docs>

To search a particular library version, browse to the required index page, and use the **Search** box at the top right, for example:

<http://www.iona.com/support/docs/artix/4.0/index.xml>

You can also search within a particular book. To search within a HTML version of a book, use the **Search** box at the top left of the page. To search within a PDF version of a book, in Adobe Acrobat, select **Edit|Find**, and enter your search text.

## Artix Online Help

Artix Designer and Artix Orchestration Designer include comprehensive online help, providing:

- Step-by-step instructions on how to perform important tasks
- A full search feature
- Context-sensitive help for each screen

There are two ways that you can access the online help:

- Select **Help|Help Contents** from the menu bar. The help appears in the contents panel of the Eclipse help browser.
- Press **F1** for context-sensitive help.

In addition, there are a number of cheat sheets that guide you through the most important functionality in Artix Designer and Artix Orchestration Designer. To access these, select **Help|Cheat Sheets**.

## Artix Glossary

The [Artix Glossary](#) is a comprehensive reference of Artix terms. It provides quick definitions of the main Artix components and concepts. All terms are defined in the context of the development and deployment of Web services using Artix.

## Additional Resources

The [IONA Knowledge Base](http://www.iona.com/support/knowledge_base/index.xml) ([http://www.iona.com/support/knowledge\\_base/index.xml](http://www.iona.com/support/knowledge_base/index.xml)) contains helpful articles written by IONA experts about Artix and other products.

The [IONA Update Center](http://www.iona.com/support/updates/index.xml) (<http://www.iona.com/support/updates/index.xml>) contains the latest releases and patches for IONA products.

If you need help with this or any other IONA product, go to [IONA Online Support](http://www.iona.com/support/index.xml) (<http://www.iona.com/support/index.xml>).

Comments, corrections, and suggestions on IONA documentation can be sent to [docs-support@iona.com](mailto:docs-support@iona.com).

## Document Conventions

### Typographical conventions

This book uses the following typographical conventions:

<code>Fixed width</code>	<p>Fixed width (courier font) in normal text represents portions of code and literal names of items such as classes, functions, variables, and data structures. For example, text might refer to the <code>IT_Bus : AnyType</code> class.</p> <p>Constant width paragraphs represent code examples or information a system displays on the screen. For example:</p> <pre>#include &lt;stdio.h&gt;</pre>
<code>Fixed width italic</code>	<p>Fixed width italic words or characters in code and commands represent variable values you must supply, such as arguments to commands or path names for your particular system. For example:</p> <pre>% cd /users/<i>YourUserName</i></pre>
<i>Italic</i>	<p>Italic words in normal text represent <i>emphasis</i> and introduce <i>new terms</i>.</p>
<b>Bold</b>	<p>Bold words in normal text represent graphical user interface components such as menu commands and dialog boxes. For example: the <b>User Preferences</b> dialog.</p>

## Keying Conventions

This book uses the following keying conventions:

No prompt	When a command's format is the same for multiple platforms, the command prompt is not shown.
%	A percent sign represents the UNIX command shell prompt for a command that does not require root privileges.
#	A number sign represents the UNIX command shell prompt for a command that requires root privileges.
>	The notation > represents the MS-DOS or Windows command prompt.
...	Horizontal or vertical ellipses in format and syntax descriptions indicate that material has been eliminated to simplify a discussion.
[ ]	Brackets enclose optional items in format and syntax descriptions.
{ }	Braces enclose a list from which you must choose an item in format and syntax descriptions.
	In format and syntax descriptions, a vertical bar separates items in a list of choices enclosed in { } (braces).  In graphical user interface descriptions, a vertical bar separates menu commands (for example, select <b>File   Open</b> ).





# Introduction to CORBA Web Services

*Artix provides a flexible framework for bridging between CORBA and Web Services domains. Several different approaches can be used to integrate a CORBA application into a Web Services domain and this introduction provides a brief overview of some typical integration scenarios.*

---

**In this chapter**

This chapter discusses the following topics:

<a href="#">Artix Architecture</a>	<a href="#">page 18</a>
<a href="#">Integrating a CORBA Server with Web Services</a>	<a href="#">page 22</a>
<a href="#">Integrating a CORBA Client with Web Services</a>	<a href="#">page 27</a>

# Artix Architecture

## Overview

The key feature of the Artix architecture is that it supports multiple communication protocols. With the help of the plug-in development APIs, moreover, it is possible to extend Artix to support *any* custom protocol.

Figure 1 illustrates this multi-protocol support, showing an Artix application that is capable of sending or receiving operation invocations over three different protocols: SOAP/MQ, SOAP/HTTP, and IIOP.

**Figure 1:** *Artix Application with Multiple Bindings and Transports*

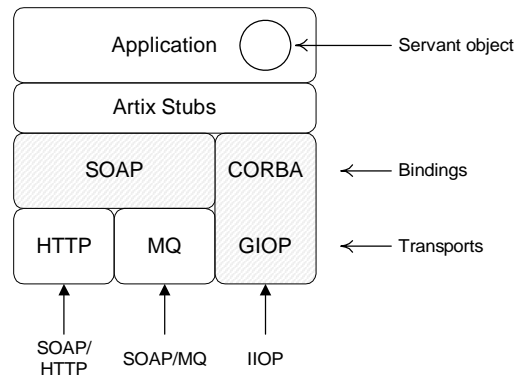

## WSDL contract

The Web Services Definition Language (WSDL) contract plays a central role in Artix. It defines the interfaces (or *port types*) and operations for a Web service. In this respect, the WSDL contract is analogous to an IDL interface in CORBA. However, WSDL contracts contain more than just interface definitions. The main elements of a WSDL contract are as follows:

- *Port types*—a port type is analogous to an IDL interface. It defines remotely callable operations that have parameters and return values.
- *Bindings*—a binding describes how to encode all of the operations and data types associated with a particular port type. A binding is specific to a particular protocol—for example, SOAP or CORBA.

- *Port definitions*—a port contains endpoint data that enables clients to locate and connect to a remote server. For example, a CORBA port might contain stringified IOR data.
- 

**Servant object**

An Artix servant provides the implementation of a port type (analogously to the way in which an Orbix servant provides the implementation of an IDL interface). The servant class is implemented using the appropriate language mapping (an IONA proprietary mapping for C++ or a standard JAX-RPC mapping for Java).

---

**Artix stubs**

The Artix stub contains the code that is needed to encode and decode the messages received and sent by an Artix application. Artix provides command-line tools to generate the stub code from WSDL, as follows:

- `wsdltocpp` command—generates C++ stub code from WSDL.
  - `wsdltojava` command—generates Java stub code from WSDL.
- 

**Bindings**

A binding is a particular kind of encoding for operations and data types (for example, CORBA or SOAP). Support for a binding is enabled by loading the relevant plug-in (for example, the `soap` plug-in for SOAP, or the `ws_orb` plug-in for CORBA, and so on).

In addition to loading the relevant plug-in, you must also provide an XML description of the binding in the WSDL contract. Artix provides tools that will generate the binding for you automatically; there is no need to write them by hand.

---

**Transports**

A transport is responsible for sending and receiving messages over a specific transport protocol (for example, HTTP or MQ-Series). Support for a transport is enabled by loading the relevant plug-in (for example, the `mq` plug-in for MQ-Series, or the `at_http` plug-in for HTTP).

In Artix, transports are closely associated with port definitions. For example, if you include either a `<http-conf:client/>` or a `<http-conf:server/>` tag within the scope of a `port` element, this indicates that the port uses the HTTP transport.

**Artix routers**

An Artix router is used to bridge operation invocations between different communication protocols. [Figure 2](#) shows an example of a SOAP/HTTP-to-CORBA router. This router translates incoming SOAP/HTTP request messages into outgoing IIOB request messages. On the reply cycle, the router translates incoming IIOB reply messages into outgoing SOAP/HTTP reply messages.

**Figure 2:** *Example of a SOAP/HTTP-to-CORBA Router*

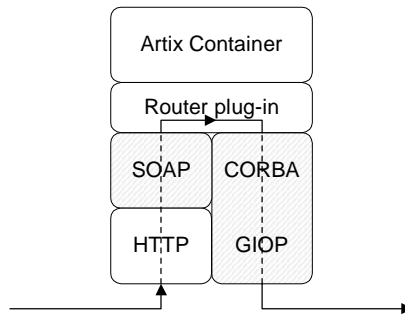

**Artix container**

The Artix container, `it_container`, is an application that can be used to run any of the standard Artix services. The functionality of the container is determined by the plug-ins it loads at runtime.

By loading the `router` plug-in (along with the requisite binding and transport plug-ins) the container is configured to run as a standalone router.

**Router plug-in**

The router plug-in implements a general-purpose protocol bridge. Messages that arrive on one port are sent out on another port.

For example, the router plug-in shown in [Figure 2 on page 20](#) receives request messages over the SOAP/HTTP protocol and forwards the request message out again over the IIOB protocol.

## Routes

To configure a router, you need to specify which ports are connected to which other ports. Use the `ns1:route` element to connect a source port to a destination port. For example:

```
<ns1:route name="route_0">
  <ns1:source      service="tns:<SourceService>"
                  port="<SourcePort>" />
  <ns1:destination service="tns:<DestinationService>"
                  port="<DestinationPort>" />
</ns1:route>
```

---

# Integrating a CORBA Server with Web Services

## Overview

---

This section considers the problem of a legacy CORBA server that is to be opened up to Web services applications. Artix supports a variety of solutions to this integration problem, which are briefly described in the following subsections.

## In this section

---

This section contains the following subsections:

<a href="#">Accessing the CORBA Server through a Standalone Router</a>	<a href="#">page 23</a>
<a href="#">Accessing the CORBA Server through an Embedded Router</a>	<a href="#">page 24</a>
<a href="#">Replacing the WS Client by an Artix Client</a>	<a href="#">page 25</a>
<a href="#">Replacing the CORBA Server by an Artix Server</a>	<a href="#">page 26</a>

---

## Accessing the CORBA Server through a Standalone Router

---

### Overview

One of the simplest ways to integrate a WS client with a CORBA server is to deploy a *standalone router* to act as a bridge between them. This approach can be used in any system.

Figure 3 shows a CORBA server that is accessible through a standalone router. The router is responsible for mapping incoming SOAP/HTTP requests into outgoing IIOP requests.

**Figure 3:** *WS Client Accesses CORBA Server through Standalone Router*

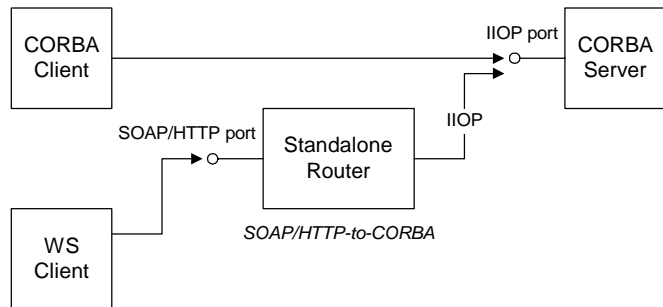

---

### Advantages and disadvantages

This scenario offers the following advantages:

- Compatible with any CORBA server.
- Compatible with any WS client.
- Non-intrusive—no changes need be made either to the client or to the server.

And the following disadvantage:

- Loss of performance—every operation invocation that passes through the router consists of two remote invocations (client-to-router followed by router-to-server).

---

## Accessing the CORBA Server through an Embedded Router

---

### Overview

If the CORBA server is implemented using an Orbix 6.x product, it is usually possible to embed the Artix router directly into the Orbix executable. This approach yields significant performance gains.

Figure 4 shows an example of a CORBA server that is accessible through an embedded router. The router is responsible for mapping incoming SOAP/HTTP requests into colocated IIOp requests.

**Figure 4:** *WS Client Accesses CORBA Server through Embedded Router*

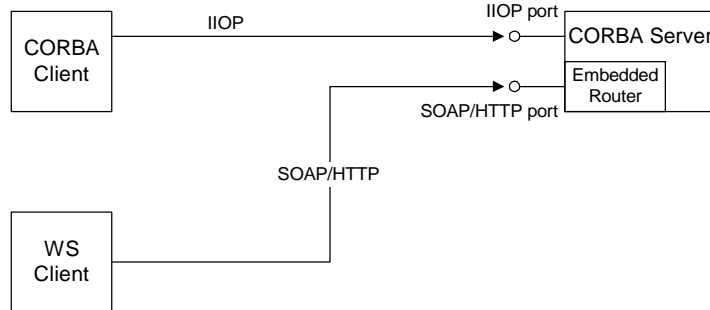

---

### Advantages and disadvantages

This scenario offers the following advantages:

- Compatible with Orbix 6.x implementations of the CORBA server.
- Compatible with any WS client.
- No changes need be made to the WS client.
- The CORBA server must be reconfigured, but remains otherwise unchanged.

And the following disadvantage:

- Moderate performance—this scenario is more efficient than using a standalone router, but is not as efficient as some other scenarios.



---

## Replacing the WS Client by an Artix Client

---

### Overview

If you have not implemented the WS client yet, you could implement it using Artix. An Artix client offers great flexibility, because it can communicate through multiple protocols, including IIOP and SOAP/HTTP.

Figure 5 shows an example of a CORBA server that is accessed by an Artix client and a CORBA client. The Artix client is configured to talk directly to the CORBA server using the IIOP protocol.

**Figure 5:** *Replacing the WS Client by an Artix Client*

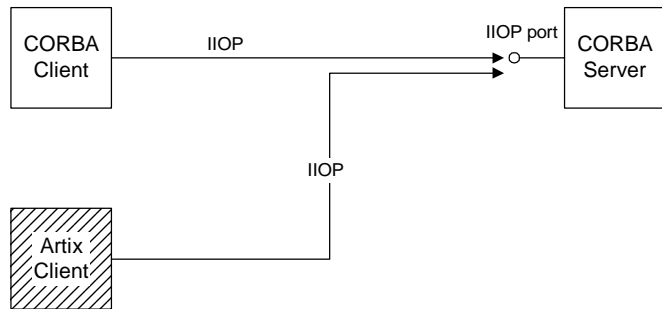

---

### Advantages and disadvantages

This scenario offers the following advantages:

- Compatible with any CORBA server.
- No changes need be made to the CORBA server.
- Performance is optimized.
- Artix client offers flexibility for future integration.

And the following disadvantage:

- If you have already implemented the WS client, you would have to re-write it to use the Artix APIs.

---

## Replacing the CORBA Server by an Artix Server

---

### Overview

If you want to exploit the full power of the Artix product, you might find it worthwhile to replace the CORBA server by re-implementing it as an Artix server. Because Artix supports multiple protocols, an Artix server can easily support present and future integration requirements.

Figure 6 shows an example of an Artix server that is accessed by a WS client and a CORBA client. The Artix server is configured to accept requests both from CORBA clients and WS clients.

**Figure 6:** *Replacing the CORBA Server by an Artix Server*

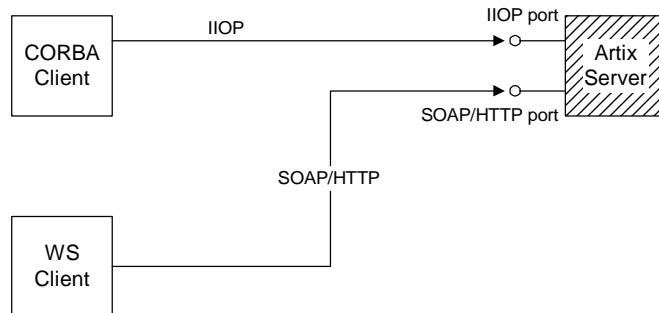

---

### Advantages and disadvantages

This scenario offers the following advantages:

- Compatible with any WS client.
- No changes need be made to the WS client.
- Performance is optimized.
- Artix server offers flexibility for future integration.

And the following disadvantage:

- You must re-implement the CORBA server as an Artix server.

---

# Integrating a CORBA Client with Web Services

---

**Overview**

This section considers the problem of CORBA client that needs to access a Web services server. Artix supports a variety of solutions to this integration problem, which are briefly described in the following subsections.

---

**In this section**

This section contains the following subsections:

<a href="#">Accessing the WS Server through a Standalone Router</a>	<a href="#">page 28</a>
<a href="#">Replacing the CORBA Client by an Artix Client</a>	<a href="#">page 29</a>
<a href="#">Replacing the WS Server by an Artix Server</a>	<a href="#">page 30</a>

---

## Accessing the WS Server through a Standalone Router

---

### Overview

A relatively simple way to integrate a CORBA client with a WS server is to deploy a *standalone router* to act as a bridge between them. This approach can be used in any system.

Figure 7 shows a WS server that is accessible through a standalone router. The router is responsible for mapping incoming IIOP requests into outgoing SOAP/HTTP requests.

**Figure 7:** Client Accesses the WS Server through a Standalone Router

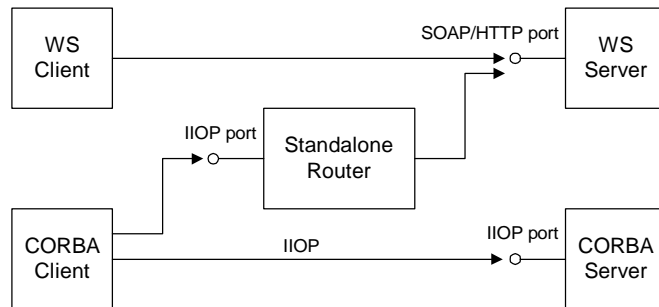

---

### Advantages and disadvantages

This scenario offers the following advantages:

- Compatible with any WS server.
- Compatible with any CORBA client.
- Non-intrusive—no changes need be made either to the client or to the server.

And the following disadvantage:

- Loss of performance—every operation invocation that passes through the router consists of two remote invocations (client-to-router followed by router-to-server). This has a noticeable impact on performance.

---

## Replacing the CORBA Client by an Artix Client

---

### Overview

To exploit the full power of the Artix product, you might find it worthwhile to replace the CORBA client by re-implementing it as an Artix client. The Artix client can then communicate using a wide variety of protocols, including IIOP and SOAP/HTTP.

Figure 8 shows an example of a WS server that is accessed by an Artix client and a WS client. The Artix client is configured to talk directly to the WS server using the SOAP/HTTP protocol.

**Figure 8:** *Replacing the CORBA Client by an Artix Client*

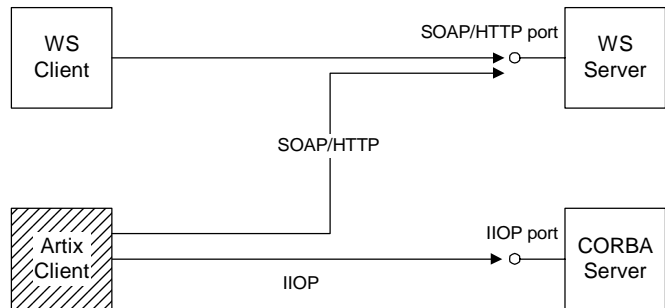

---

### Advantages and disadvantages

This scenario offers the following advantages:

- Compatible with any WS server.
- No changes need be made to the WS server.
- Performance is optimized.
- Artix client offers flexibility for future integration.

And the following disadvantage:

- You must re-implement the CORBA client as an Artix client.

---

## Replacing the WS Server by an Artix Server

---

### Overview

If you want to exploit the full power of the Artix product, you might find it worthwhile to replace the WS server by re-implementing it as an Artix server. Because Artix supports multiple protocols, an Artix server can easily support present and future integration requirements.

Figure 9 shows an example of an Artix server that is accessed by a WS client and a CORBA client. The Artix server is configured to accept requests both from CORBA clients and WS clients.

**Figure 9:** *Replacing the WS Server by an Artix Server*

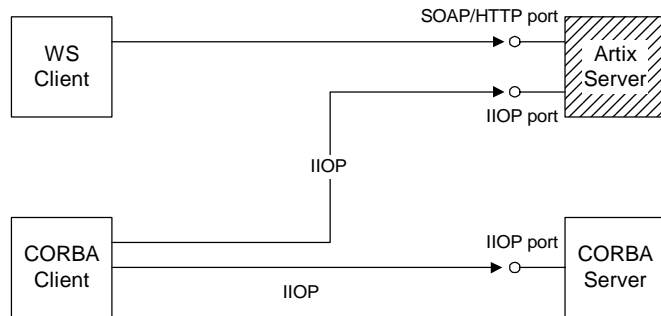

---

### Advantages and disadvantages

This scenario offers the following advantages:

- Compatible with any CORBA client.
- No changes need be made to the CORBA client.
- Performance is optimized.
- Artix server offers flexibility for future integration.

And the following disadvantage:

- If you have already implemented the WS server using a third-party product, you would have to re-write it as an Artix server.

# Exposing a Web Service as a CORBA Service

*This chapter describes how to expose a Web service as a CORBA service using Artix. If the Web Service is implemented using Artix, it is relatively easy to integrate with CORBA; if implemented using a third-party product, integration is made possible using Artix routers.*

---

**In this chapter**

This chapter discusses the following topics:

<a href="#">Converting WSDL to IDL</a>	<a href="#">page 32</a>
<a href="#">Exposing an Artix Web Service as a CORBA Service</a>	<a href="#">page 35</a>
<a href="#">Exposing a Non-Artix Web Service as a CORBA Service</a>	<a href="#">page 39</a>
<a href="#">Using an Orbix 3.3 Client to Access an Artix Server</a>	<a href="#">page 47</a>
<a href="#">High Performance Java CORBA Binding</a>	<a href="#">page 50</a>

---

# Converting WSDL to IDL

---

## Overview

To convert a WSDL contract to an equivalent OMG IDL interface (or interfaces), perform the following steps:

1. [Add CORBA bindings to WSDL.](#)
  2. [Add CORBA endpoints to WSDL.](#)
  3. [Generate the IDL.](#)
- 

## Add CORBA bindings to WSDL

Generate a CORBA binding for each port type that you want to expose as an IDL interface:

- If you want to expose a *single* WSDL port type from the WSDL file, `<WSDLFile>.wsdl`, enter the following command:

```
> wsdltoCorba -corba -i <PortTypeName> <WSDLFile>.wsdl
```

Where `<PortTypeName>` refers to the `name` attribute of an existing `portType` element. This command generates a new WSDL file, `<WSDLFile>-corba.wsdl`.

- If you want to expose *multiple* WSDL port types, you must run the `wsdltoCorba` command iteratively, once for each port type. For example:

```
> wsdltoCorba -corba -i <PortType_A> -o <WSDLFile>01.wsdl
<WSDLFile>.wsdl
```

```
> wsdltoCorba -corba -i <PortType_B> -o <WSDLFile>02.wsdl
<WSDLFile>01.wsdl
```

```
> wsdltoCorba -corba -i <PortType_C> -o <WSDLFile>03.wsdl
<WSDLFile>02.wsdl
```

...

Where the `-o` flag is used to specify the name of the output file at each stage. Rename the last file in the sequence to

```
<WSDLFile>-corba.wsdl.
```



**Add CORBA endpoints to WSDL**

It is not strictly necessary to add CORBA endpoints to the WSDL at this stage (that is, prior to generating the IDL), but it is convenient to make these modifications to the WSDL contract now.

To add the CORBA endpoints, open the *<WSDLFile>* `-corba.wsdl` file generated in the previous step and add a `service` element for each of the port types you want to expose. For example, a simple CORBA endpoint that is associated with the *<CORBABinding>* binding could have the following form:

```
<definitions name="" targetNamespace="..."
...
xmlns:corba="http://schemas.ionac.com/bindings/corba"
...>
...
<service name="<CORBAServiceName>">
  <port binding="tns:<CORBABinding>" name="<CORBAPortName>">
    <corba:address location="file:///greeter.ior"/>
  </port>
</service>
</definitions>
```

The value of the `location` attribute in the `corba:address` element can be specified as one of the following URL types:

- *File URL*—to configure the Artix server to write an IOR to a file as it starts up, specify the `location` attribute as follows:

```
location="file:///<DirPath>/<IORFile>.ior"
```

On Windows platforms, the URL format can indicate a particular drive—for example the `C:` drive—as follows:

```
location="file:///C:/<DirPath>/<IORFile>.ior"
```

**Note:** It is usually simplest to specify the file name using an absolute path. If you specify the file name using a relative path, the location is taken to be relative to the directory the Artix process is started in, *not* relative to the containing WSDL file.

- *corbaname URL*—to configure the Artix server to bind an object reference in the CORBA naming service, specify the `location` attribute as follows:

```
location="corbaname:rir:/NameService#<StringName>"
```

Where *StringName* is a name in the CORBA naming service. For more details, see [“How an Artix Client Resolves a Name” on page 88](#).

- *Placeholder IOR*—is appropriate for IORs created dynamically at runtime (for example, IORs created by factory objects). In this case, you should use the special placeholder value, `IOR:`, for the location attribute, as follows:

```
location="IOR:"
```

Artix then uses the enclosing `service` element as a template for transient object references.

**Note:** It is also possible to add a CORBA endpoint to the WSDL contract using the `wsdltoservice` command line tool. For details of this command, see the *Command Line Reference* document.

## Generate the IDL

Generate an IDL interface for each port type, as follows:

- To generate IDL for a *single* port type, select the relevant CORBA binding, `<CORBABinding>`, from the WSDL and enter the following command:

```
> wsdltocorba -idl -b <CORBABinding>
  <WSDLFile>-corba.wsdl
```

The output from this command is written to an IDL file, `<WSDLFile>-corba.idl`. If you want to change the name of the IDL output file, you can use the `-o <IDLFileName>` option.

- To generate IDL for *multiple* port types, you must run the `wsdltocorba` command once for each port type. After generating all of the IDL interfaces individually, you would typically concatenate the output files into a single IDL file.

---

# Exposing an Artix Web Service as a CORBA Service

## Overview

It is relatively straightforward to expose an Artix Web service as a CORBA service. Essentially, you must add the configuration of the relevant CORBA bindings to the WSDL contract and ensure that the requisite CORBA plug-ins are loaded into the Artix application.

In detail, the steps for exposing an Artix service as a CORBA service are as follows:

1. [Convert WSDL to IDL.](#)
2. [Write code to activate the CORBA endpoints.](#)
3. [Re-build the Artix server.](#)
4. [Configure the Artix server.](#)

---

## Convert WSDL to IDL

Follow the instructions in [“Converting WSDL to IDL” on page 32](#) to convert your WSDL contract to IDL. The output from this step consists of two files, as follows:

- *Modified WSDL file*—the WSDL contract is modified to include CORBA bindings and CORBA endpoints. The Artix server needs the modified contract to expose the service over CORBA.
- *IDL file*—an IDL file is generated from the modified WSDL. CORBA clients use this IDL file to access the CORBA service exposed by the Artix server.

**Write code to activate the CORBA endpoints**

In the main function of your application source code, add some code to activate the CORBA endpoints. For example, given the following `service` element in the WSDL contract:

```
<definitions name="" targetNamespace="<TargetNameSpace>"
  ...
  xmlns:corba="http://schemas.iona.com/bindings/corba"
  ...>
  ...
  <service name="<CORBAServiceName>">
    <port binding="tns:<CORBABinding>" name="<CORBAPortName>">
      <corba:address location="..."/>
    </port>
  </service>
</definitions>
```

You can activate all of the ports in the `<CORBAServiceName>` service by registering a servant, as follows:

```
// C++
IT_Bus::QName m_service_qname("", "<CORBAServiceName>",
  "<TargetNameSpace>")

m_bus()->register_servant(
  m_servant,           // Service implementation
  "<WSDLFile>.wsdl",  // WSDL file location
  m_service_qname     // Service QName
);
```

Where `m_servant` is an object that implements a WSDL port type. This could be the very same object that is registered with other protocols, such as SOAP/HTTP, or it could be a new instance of the service. The second argument, `<WSDLFile>.wsdl`, gives the location of the modified WSDL contract. In this example, it is assumed that the WSDL contract is stored in the same directory as the application executable.

**Note:** For more details about activating service endpoints and registering servants, see the “Artix Programming Considerations” chapter from *Developing Artix Applications in C++*.

**Re-build the Artix server**

Before re-building the Artix server executable, you must regenerate the Artix stub files from the modified WSDL contract. In particular, you must ensure that C++ code is generated for each of the newly-defined CORBA bindings. After regenerating the stub files, you can re-build the Artix server.

**Configure the Artix server**

The Artix server must be configured to load the requisite CORBA plug-ins. [Example 1](#) shows how to modify the Artix configuration scope, `artix_srvr_with_corba_binding`, to enable the CORBA bindings.

**Example 1:** *Artix Configuration Required for a CORBA Binding*

```
# Artix Configuration File

artix_srvr_with_corba_binding {
    ...

    # Modified configuration required for a CORBA binding:
    #
    1 orb_plugins = [..., "iiop_profile", "giop", "iiop",
      "ws_orb"];
    2 binding:client_binding_list =
      ["OTS+POA_Coloc", "POA_Coloc", "OTS+GIOP+IIOP", "GIOP+IIOP"];
    3
      plugins:iiop_profile:shlib_name = "it_iiop_profile";
      plugins:giop:shlib_name = "it_giop";
      plugins:iiop:shlib_name = "it_iiop";
      plugins:ws_orb:shlib_name = "it_ws_orb";
};
```

The preceding Artix configuration can be explained as follows:

1. Edit the ORB plug-ins list, adding the plug-ins needed to support CORBA bindings. The following additional plug-ins are needed:
  - ◆ `iiop_profile`, `giop`, and `iiop` plug-ins—provide support for the Internet Inter-ORB Protocol (IIOP), which is used by CORBA.
  - ◆ `ws_orb` plug-in—enables the Artix application to send and receive CORBA messages.
2. You should ensure that the `binding:client_binding_list` (either within this scope or in the nearest enclosing scope) includes bindings with the `GIOP+IIOP` protocol combination. The client binding list shown here is a typical default setting.

3. For each of the additional plug-ins you must specify the *root name* of the shared library (or DLL on Windows) that contains the plug-in code. The requisite `plugins:<plugin_name>:shlib_name` entries can be copied from the root scope of the Artix configuration file, `artix.cfg`. You can optionally specify additional configuration settings for the plug-ins at this point (see the *Artix Configuration Reference* for more details).

---

# Exposing a Non-Artix Web Service as a CORBA Service

## Overview

---

If you want to expose a non-Artix Web service as a CORBA service, you must deploy a standalone Artix router that acts as a bridge between CORBA clients and the Web services server.

---

## In this section

This section contains the following subsections:

<a href="#">Standalone CORBA-to-SOAP Router Scenario</a>	<a href="#">page 40</a>
--	-------------------------

<a href="#">Configuring and Running a Standalone CORBA-to-SOAP Router</a>	<a href="#">page 41</a>
---	-------------------------

## Standalone CORBA-to-SOAP Router Scenario

### Overview

Figure 10 shows an overview of a standalone CORBA-to-SOAP router. In this scenario, the router is packaged as a standalone application, which acts as a bridge between the CORBA client and the Web services server. The standalone router is responsible for converting incoming CORBA requests into outgoing requests on the Web services server. Replies from the Web services server are converted into CORBA replies by the router and sent back to the client.

**Figure 10:** *Standalone Artix Router*

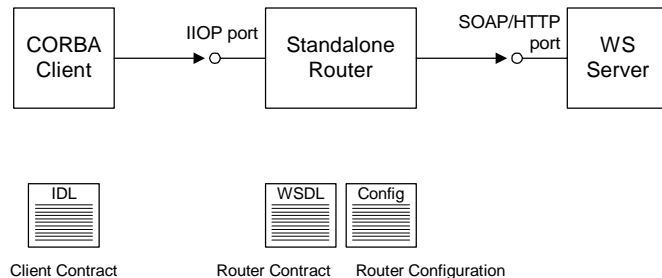

### Container

The Artix container, `it_container`, is an executable that can be used to run any of the standard Artix services. The functionality of the container is determined by the plug-ins it loads at runtime.

In this scenario, the container is configured to load the `router` plug-in (along with some other plug-ins) so that it functions as a standalone router.

### Modifications to CORBA server

When using a standalone Artix router, no modifications need be made to the CORBA server.

### Elements required for this scenario

The following elements are required to implement this scenario:

- IDL interface for clients.
- WSDL contract for the standalone router.
- Artix configuration file for the standalone router.



---

# Configuring and Running a Standalone CORBA-to-SOAP Router

---

## Overview

This section describes how to configure and run a standalone router that acts as a bridge between CORBA clients and a SOAP/HTTP Web services server. The following steps are described:

1. [Convert WSDL to IDL](#).
2. [Generate the router.wSDL file](#).
3. [Create the Artix configuration](#).
4. [Run the standalone router](#).

---

## Convert WSDL to IDL

Follow the instructions in [“Converting WSDL to IDL” on page 32](#) to convert your WSDL contract to IDL and to generate CORBA bindings and CORBA endpoints in the WSDL contract. The output from this step is a modified WSDL file, `<WSDLFile>.wSDL`, and an IDL file.

---

## Generate the router.wSDL file

To generate the `router.wSDL` file, you need to augment the `<WSDLFile>.wSDL` file from the previous step. Specifically, you must add the requisite bindings and endpoints for the second leg of the route, which goes from the router to the SOAP Web service.

1. *Generate CORBA bindings and CORBA endpoints*—if you followed the steps in [“Converting WSDL to IDL” on page 32](#), the `<WSDLFile>.wSDL` file already contains the relevant CORBA bindings and CORBA endpoints.
2. *Generate SOAP bindings*—generate a SOAP binding for each port type that is exposed as an IDL interface. The router acts like a SOAP client with respect to the SOAP Web services server.

If the router needs to access a *single* WSDL port type, generate a SOAP binding with the following command:

```
> wsdltosoap -i <PortTypeName> -b <BindingName>
   <WSDLFile>.wSDL
```

Where `<PortTypeName>` refers to the `name` attribute of an existing `portType` element and `<BindingName>` is the name to be given to the newly generated SOAP binding. This command generates a new WSDL file, `<WSDLFile>-soap.wSDL`.

If the router needs to access *multiple* WSDL port types, you must run the `wsdltosoap` command iteratively, once for each port type. For example:

```
> wsdltosoap -i <PortType_A> -b <Binding_A>
  -o <WSDLFile>01.wsd1 <WSDLFile>.wsdl
> wsdltosoap -i <PortType_B> -b <Binding_B>
  -o <WSDLFile>02.wsd1 <WSDLFile>01.wsd1
> wsdltosoap -i <PortType_C> -b <Binding_C>
  -o <WSDLFile>03.wsd1 <WSDLFile>02.wsd1
...
...
```

Where the `-o <FileName>` flag specifies the name of the output file. At the end of this step, rename the WSDL file to `router.wsd1`.

3. Add SOAP endpoints—add a `service` element for each of the port types you want to expose. For example, a simple SOAP endpoint could have the following form:

```
<definitions name="" targetNamespace="..."
...
xmlns:soap="http://schemas.xmlsoap.org/wsdl/soap/"
xmlns:http-conf="http://schemas.iona.com/transport/http/configuration"
...>
...
<service name="<SOAPServiceName>">
  <port binding="tns:<SOAPBinding>" name="<SOAPPortName>">
    <soap:address location="http://localhost:9000"/>
    <http-conf:client/>
    <http-conf:server/>
  </port>
</service>
</definitions>
```

In the preceding example, you must add a line that defines the `http-conf` namespace prefix in the `<definitions>` tag.

The most important setting in the SOAP port is the `location` attribute of the `soap:address` element, which can be set to one of the following HTTP URLs:

- ◆ Explicit HTTP URL—if a particular service is provided at a fixed address, you can specify the `<hostname>` and `<port>` values explicitly.

```
location="http://<hostname>:<port>
```

- ◆ Placeholder HTTP URL—if a service is created dynamically at runtime, you should specify a transient HTTP URL, as follows:

```
location="http://localhost:0
```

At runtime, the placeholder URL is replaced by an explicit address. Artix then treats the enclosing `service` element as a template, allowing multiple transient services to be created at runtime.

**Note:** It is also possible to add a SOAP endpoint to the WSDL contract using the `wsdltoservice` command line tool. For details of this command, see the *Command Line Reference* document.

4. Add a route for each exposed port type—for each port type, you need to set up a route to translate incoming CORBA requests into outgoing SOAP requests. For example, the following route definition instructs the router to map incoming CORBA request messages to a SOAP/HTTP endpoint.

```
<definitions name="" targetNamespace="TargetNamespaceURI"
  ...
  xmlns:tns="TargetNamespaceURI"
  xmlns:ns1="http://schemas.ionas.com/routing"
  ...>
  ...
  <ns1:route name="route_0">
    <ns1:source      service="tns:<CORBAServiceName>"
                    port="<CORBAPortName>"/>
    <ns1:destination service="tns:<SOAPServiceName>"
                    port="<SOAPPortName>"/>
  </ns1:route>
</definitions>
```

In the preceding example, you must add a line that defines the `ns1` namespace prefix in the `<definitions>` tag.

The `ns1:source` element identifies the CORBA endpoint in the router that receives incoming requests from a client. The `ns1:destination`

element identifies the SOAP/HTTP endpoint in the Orbix server to which outgoing requests are routed.

**Note:** Generally, when defining routes, if the `location` of the source endpoint is a placeholder, the `location` of the destination endpoint should *also* be a placeholder.

5. Check that you have added all the namespaces that you need—for a typical CORBA to SOAP/HTTP route, you typically need to add the following namespaces (in addition to the namespaces already generated by default):

```
<definitions name="" targetNamespace="TargetNamespaceURI"
  ...
  xmlns:tns="TargetNamespaceURI"
  xmlns:ns1="http://schemas.iona.com/routing"
  xmlns:http-conf="http://schemas.iona.com/transport/http/configuration"
  xmlns:wsa="http://www.w3.org/2005/08/addressing"
  ...>
  ...
</definitions>
```

### Create the Artix configuration

[Example 2](#) shows a suitable configuration for a standalone router that maps incoming CORBA requests to outgoing SOAP/HTTP requests.

#### **Example 2:** *Artix Configuration Suitable for a Standalone Artix Router*

```
# Artix Configuration File
1 # Global configuration scope
  ...

standalone_router {
  # Configuration for standalone router:
  #
2  orb_plugins = ["xmlfile_log_stream", "iiop_profile", "giop",
  "iiop", "ws_orb", "soap", "at_http", "routing"];
3
  plugins:routing:wsdl_url="../../etc/router.wsdl";
4
  plugins:ws_orb:shlib_name = "it_ws_orb";
  plugins:soap:shlib_name = "it_soap";
  plugins:http:shlib_name = "it_http";
```

**Example 2:** *Artix Configuration Suitable for a Standalone Artix Router*

```

plugins:at_http:shlib_name = "it_at_http";
plugins:routing:shlib_name = "it_routing";

# Uncomment these lines for interoperability with Orbix 3.3
5 #policies:giop:interop_policy:negotiate_transmission_codeset
= "false";
#policies:giop:interop_policy:send_principal = "true";
#policies:giop:interop_policy:send_locate_request = "false";
};

```

The preceding Artix configuration can be explained as follows:

1. The basic configuration settings needed by the Artix container process are inherited from the global configuration scope.
2. Edit the ORB plug-ins, adding the requisite Artix plug-ins to the list. In this example, the following plug-ins are needed:
  - ◆ `xmlfile_log_stream` plug-in—enables logging to an XML file.
  - ◆ `iiop_profile`, `giop`, and `iiop` plug-ins—enables the IIOP protocol (used by CORBA).
  - ◆ `ws_orb` plug-in—enables the router to send and receive CORBA messages.
  - ◆ `soap` plug-in—enables the router to send and receive SOAP messages.
  - ◆ `at_http` plug-in—enables the router to send and receive messages over the HTTP transport.
  - ◆ `routing` plug-in—contains the core of the Artix router.

If you plan to use other bindings and transports, you might need to add some other Artix plug-ins instead.

3. The `plugins:routing:wSDL_url` setting specifies the location of the router WSDL contract (see [“Converting WSDL to IDL” on page 32](#)). The URL can be a relative filename (as here) or a general `file: URL`.
4. To load the Artix plug-ins, you must specify the *root name* of the shared library (or DLL on Windows) that contains the plug-in code. The requisite `plugins:<plugin_name>:shlib_name` entries can be copied from the root scope of the Artix configuration file, `artix.cfg`.

You can also specify additional plug-in configuration settings at this point (see the *Artix Configuration Reference* for more details).

5. If the router needs to integrate with Orbix 3.3 CORBA clients, you should uncomment these lines to enable interoperability. For more details about these configuration settings, see the *Artix Configuration Reference*.

**Note:** These interoperability settings might also be useful for integrating with other third-party ORB products. See the *Artix Configuration Reference* for more details.

---

### Run the standalone router

Run the standalone router by invoking the container, `it_container`, passing the router's ORB name as a command-line parameter (the ORB name is identical to the name of the router's configuration scope).

For example, to run the router configured in [Example 2 on page 44](#), enter the following at a command prompt:

```
it_container -ORBname standalone_router
```

---

# Using an Orbix 3.3 Client to Access an Artix Server

## Overview

This section gives a summary of the problems that might occur when you try to compile an Artix-generated IDL file (generated by the `wsdltocorba` tool) using the Orbix 3.3 IDL compiler.

Because the Orbix 3.3 product was designed to conform to the CORBA 2.1 specification (which is an earlier version of the CORBA specification than that used for Artix) there are some differences between the conventions used in Orbix 3.3 IDL files and the conventions used in Artix IDL files.

**Note:** The following list of issues is not necessarily exhaustive. This section summarizes only those interoperability issues known about at the time of writing.

## Incompatible `#pragma` macros

The following `#pragma` macros which appear in some standard Artix IDL files are incompatible with Orbix 3.3 and will cause the Orbix 3.3 IDL compiler to report an error:

```
#pragma IT_SystemSpecification
#pragma IT_BeginCBESpecific
```

## Data type compatibility

Most of the IDL data types generated by the Artix `wsdltocorba` tool are compatible with Orbix 3.3. But there are some exceptions. The following WSDL data types require workarounds in order to interoperate with the Orbix 3.3 product:

- [xsd:dateType type mapping to the TimeBase::UtcT IDL type.](#)
- [Complex type derived from a simple type.](#)
- [Recursive types.](#)

### xsd:dateTime type mapping to the TimeBase::UtcT IDL type

Artix uses the `TimeBase::UtcT` type to represent the `xsd:dateTime` XML schema type. To support the `TimeBase::UtcT` type, Artix-generated IDL files contain the following `#include` statement:

```
#include <omg/TimeBase.idl>
```

A problem arises, however, when the Orbix 3.3 IDL compiler attempts to compile the `TimeBase.idl` file, because the `TimeBase.idl` file includes `#pragma` macros that are incompatible with the Orbix 3.3 IDL compiler. To fix this problem, perform the following steps:

1. Make a copy of the `TimeBase.idl` file (the original of this file can be found in the `ArtixInstallDir/artix/Version/idl/omg` directory).
2. Edit the copied file to delete the following `#pragma` macros:

```
#pragma IT_SystemSpecification

#pragma IT_BeginCBESpecific AllJava           "@@\
@module TimeBase=org.omg"
```

3. Edit the `#include` statement in the main IDL file, to point at the modified copy of the `TimeBase.idl` file.

### Complex type derived from a simple type

A problem arises with XML schema complex types that are defined by derivation from a simple type. For example, consider the following schema type, `Document`, that adds a string attribute to a simple string type:

```
<xsd:complexType name="Document">
  <xsd:simpleContent>
    <xsd:extension base="xsd:string">
      <xsd:attribute name="ID" type="xsd:string"/>
    </xsd:extension>
  </xsd:simpleContent>
</xsd:complexType>
```

When the `wSDLtoCORBA` utility maps this schema type to IDL, it generates the following struct:

```
// IDL
struct Document {
  string_nil ID;
  string _simpleTypeValue;
};
```



When this IDL sample is passed to the Orbix 3.3 compiler, it fails to compile because the Orbix 3.3 compiler does not allow identifiers that begin with the `_` (underscore) character.

To work around this problem, you can manually edit the CORBA binding in the WSDL file, replacing `_simpleTypeValue` by `simpleTypeValue` (removing the underscore character). For example, for the `Document` data type, the CORBA binding defines the following mapping by default:

```
<corba:struct name="Document" repositoryID="IDL:Document:1.0"
  type="s:Document">
  <corba:member idltype="ns1:string_nil" name="ID"/>
  <corba:member idltype="corba:string"
    name="_simpleTypeValue"/>
</corba:struct>
```

To modify the mapping in this case, simply replace `_simpleTypeValue` by `simpleTypeValue` in the preceding code fragment.

---

## Recursive types

The IDL mapping for recursive XML schema types requires the use of forward declared structs in IDL. The forward declared struct is a relatively recent addition to IDL syntax and is not supported by Orbix 3.3. Hence, recursive types are incompatible with Orbix 3.3 clients.

For more details about XML schema recursive types, see [“Recursive Types” on page 179](#).

---

# High Performance Java CORBA Binding

---

## Overview

You can use an alternative Java CORBA binding, offering improved performance, in Artix server applications.

---

## Enabling the binding

To enable the Java CORBA binding, set the `java.corba.service.enabled` system property to `true`, in either of the following ways:

- By passing the following command line argument:

```
-Djava.corba.service.enabled=true
```

- By making the following API call in the application:

```
System.setProperty("java.corba.service.enabled", "true");
```

Alternatively, if you are using multiple buses, you can enable the binding for an individual bus by passing the properties to `Bus.init()`, as follows:

```
Hashtable props = new Hashtable();  
props.setProperty("java.corba.service.enabled", "true");  
Bus.init(args, props);
```

---

## Location of demonstration

For an example of the new Java CORBA binding, see the CDR over IIOP demonstration in `demos/transport/cdr_over_iiop`.

# Exposing a CORBA Service as a Web Service

*This chapter describes how to expose a CORBA service as a Web service using Artix. Different approaches can be taken, depending on whether the back-end CORBA service is implemented using the Orbix 6 product, the Orbix 3.3 product or some other third-party ORB product.*

---

**In this chapter**

This chapter discusses the following topics:

<a href="#">Converting IDL to WSDL</a>	<a href="#">page 52</a>
<a href="#">Embedding Artix in a CORBA Service</a>	<a href="#">page 61</a>
<a href="#">Exposing an Orbix 3.3 or Non-Orbix Service as a Web Service</a>	<a href="#">page 68</a>

---

# Converting IDL to WSDL

## Overview

The first step in exposing a CORBA server as a Web service is to convert the CORBA server's IDL into a WSDL contract. For all of the examples presented in this chapter, the following assumptions are made:

- The server's IDL does not feature callbacks.
- Web service clients use the SOAP/HTTP protocol.

---

## WSDL contract files

This subsection describes how to generate the following two WSDL files:

- `router.wsdl` file—deployed along with the embedded router and the Orbix server, the `router.wsdl` file contains all of the router information required to map incoming SOAP requests to outgoing CORBA requests.
- `client.wsdl` file—contains all of the information required by Web services clients to make SOAP/HTTP invocations on the router.

---

## Contents of the router contract

Given that the router has to be capable of routing incoming SOAP requests to outgoing CORBA requests, the router generally must contain the following elements:

- Port types.
- CORBA bindings.
- SOAP bindings.
- CORBA endpoints.
- SOAP/HTTP endpoints.
- Routes from SOAP/HTTP endpoints to CORBA endpoints.

---

## Generate the router contract

To generate a router contract from a given IDL file, `<IDLFile>.idl`, perform the following steps:

1. Generate WSDL from the IDL file—at a command-line prompt, enter:  

```
> idltowsdl <IDLFile>.idl
```

This command generates a WSDL file, `<IDLFile>.wsdl`, which contains the following:
  - ◆ XSD schema types, generated from the IDL data types.

- ◆ `portType` elements—a port type for each IDL interface in the source.
- ◆ `binding` elements—a CORBA binding for each port type.
- ◆ `service` elements—a CORBA endpoint for each port type

You might need to specify additional flags to the `idltowsdl` command utility. Some of the more commonly required options are:

- r *<ref\_schema>* specifies the location of the endpoint references schema. The schema file, `wsaddressing.xsd`, is located in the `ArtixInstallDir/artix/Version/schemas` directory and on the Internet. The references schema is needed whenever you generate WSDL from IDL that uses object references.
- a *<corba\_address>* specifies a default value for the `location` attribute in the `corba:address` elements.
- unwrap generates doc/literal unwrapped style of WSDL.
- usetypes generates rpc/literal style of WSDL.
- 3 specifies Orbix 3.3 compatibility mode. Use this option if the IDL file you are converting stems from a legacy Orbix 3.3 application. See [“Orbix 3 legacy compatibility” on page 227](#) for more details.

The default style of WSDL generated by the `idltowsdl` utility is doc/literal wrapped.

2. Edit the `corba:address` elements for each CORBA endpoint—for each CORBA endpoint, you have to specify the location of a CORBA object reference.

Using your favorite text editor, open the *<IDLFile>.wsdl* file generated in the previous step. Replace the dummy setting, `location="..."`, in each of the `corba:address` elements, by one of the following location URL settings:

- ◆ *File URL*—if the Orbix server writes an IOR to a file as it starts up, you specify the `location` attribute as follows:  
`location="file:///<DirPath>/<IORFile>.ior"`  
 On Windows platforms, the URL format can indicate a particular drive—for example the `c:` drive—as follows:

```
location="file:///C:/<DirPath>/<IORFile>.ior"
```

**Note:** It is usually simplest to specify the file name using an absolute path. If you specify the file name using a relative path, the location is taken to be relative to the directory the Artix process is started in, *not* relative to the containing WSDL file.

- ◆ *corbaname URL*—allows you to retrieve an object reference from the CORBA naming service. This setting has the following format:

```
location="corbaname:rir:/NameService#StringName"
```

Where *StringName* is a name in the CORBA naming service. For more details, see [“How an Artix Client Resolves a Name” on page 88](#).

- ◆ *Stringified IOR*—if you know that the Orbix server’s IOR is not going to change for some time, you can paste the stringified IOR directly into the location attribute, as follows:

```
location="IOR:000000..."
```

- ◆ *Placeholder IOR*—is appropriate for IORs created dynamically at runtime (for example, IORs created by factory objects). In this case, you should use the special placeholder value, `IOR:`, for the location attribute, as follows:

```
location="IOR:"
```

Artix uses the enclosing `service` element as a template for transient object references.

For example, if your Orbix server writes an IOR to the file, `/tmp/app_iors/hello_world_service.ior`, you can use it to specify the endpoint location as follows:

```
<service name="HelloWorldCORBAService">
  <port binding="tns:HelloWorldCORBABinding" name="HelloWorldCORBAPort">
    <corba:address location="file:///tmp/app_iors/hello_world_service.ior"/>
  </port>
</service>
```

3. Generate SOAP bindings—generate a SOAP binding for each port type that you want to expose as a Web service. If you want to expose a single WSDL port type, enter the following command:

```
> wsdltosoap -i <PortTypeName> -b <BindingName>
<IDLFile>.wsdl
```

Where `<PortTypeName>` refers to the `name` attribute of an existing `portType` element and `<BindingName>` is the name to be given to the newly generated SOAP binding. This command generates a new WSDL file, `<IDLFile>-soap.wsdl`.

If you want to expose *multiple* WSDL port types, you must run the `wsdltosoap` command iteratively, once for each port type. For example:

```
> wsdltosoap -i <PortType_A> -b <Binding_A>
-o <IDLFile>01.wsdl <IDLFile>.wsdl
> wsdltosoap -i <PortType_B> -b <Binding_B>
-o <IDLFile>02.wsdl <IDLFile>01.wsdl
> wsdltosoap -i <PortType_C> -b <Binding_C>
-o <IDLFile>03.wsdl <IDLFile>02.wsdl
...
```

Where the `-o <FileName>` flag specifies the name of the output file. At the end of this step, rename the WSDL file to `router.wsdl`.

4. Add SOAP endpoints—add a `service` element for each of the port types you want to expose. For example, a simple SOAP endpoint could have the following form:

```
<definitions name="" targetNamespace="..."
...
xmlns:soap="http://schemas.xmlsoap.org/wsdl/soap/"
xmlns:http-conf="http://schemas.iona.com/transport/http/configuration"
...>
...
<service name="<SOAPServiceName>">
  <port binding="tns:<SOAPBinding>" name="<SOAPPortName>">
    <soap:address location="http://localhost:9000"/>
    <http-conf:client/>
    <http-conf:server/>
  </port>
</service>
</definitions>
```

In the preceding example, you must add a line that defines the `http-conf` namespace prefix in the `<definitions>` tag.

The most important setting in the SOAP port is the `location` attribute of the `soap:address` element, which can be set to one of the following HTTP URLs:

- ◆ Explicit HTTP URL—if a particular service is meant to listen on a fixed address, you can specify the `<hostname>` and `<port>` values explicitly.

```
location="http://<hostname>:<port>
```

- ◆ Placeholder HTTP URL—if a service is meant to be created dynamically at runtime, you should specify a transient HTTP URL, as follows:

```
location="http://localhost:0
```

At runtime, the placeholder URL is replaced by an explicit address when the service is created. Artix treats the enclosing `service` element as a template, allowing multiple transient services to be created at runtime.

**Note:** It is also possible to add a SOAP endpoint to the WSDL contract using the `wsdltoservice` command line tool. For details of this command, see the *Command Line Reference* document.

5. Add a route for each exposed port type—for each port type, you need to set up a route to translate incoming SOAP requests into outgoing CORBA requests. For example, the following route definition instructs the router to map incoming SOAP/HTTP request messages to a CORBA endpoint.

```
<definitions name="" targetNamespace="TargetNamespaceURI"
...
xmlns:tns="TargetNamespaceURI"
xmlns:ns1="http://schemas.iona.com/routing"
...>
...
<ns1:route name="route_0">
  <ns1:source      service="tns:<SOAPServiceName>"
                  port="<SOAPPortName>" />
  <ns1:destination service="tns:<CORBAServiceName>"
                  port="<CORBAPortName>" />
</ns1:route>
</definitions>
```

In the preceding example, you must add a line that defines the `ns1` namespace prefix in the `<definitions>` tag.



The `ns1:source` element identifies the SOAP/HTTP endpoint in the router that receives incoming requests from a client. The `ns1:destination` element identifies the CORBA endpoint in the Orbix server to which outgoing requests are routed.

**Note:** Generally, when defining routes, if the location of the source endpoint is a placeholder, the location of the destination endpoint should *also* be a placeholder.

6. Check that you have added all the namespaces that you need—for a typical SOAP/HTTP to CORBA route, you typically need to add the following namespaces (in addition to the namespaces already generated by default):

```
<definitions name="" targetNamespace="TargetNamespaceURI"
...
xmlns:tns="TargetNamespaceURI"
xmlns:ns1="http://schemas.ionas.com/routing"
xmlns:http-conf="http://schemas.ionas.com/transport/http/configuration"
xmlns:wsa="http://www.w3.org/2005/08/addressing"
...>
...
</definitions>
```

7. Include the WS-Addressing schema (if required)—if your IDL passes any object references (for example, as parameters or return values), the corresponding WSDL contract needs to include the WS-Addressing schema to represent the object references.

For example, assuming that the `wsaddressing.xsd` schema file is stored in the same directory as `router.wsdl`, you can include the WS-Addressing schema in the router contract as follows:

```
<definitions name="" targetNamespace="TargetNamespaceURI"
  ...>
  <types>
    <schema targetNamespace="..." ...>
      <import namespace="http://www.w3.org/2005/08/addressing"
        schemaLocation="wsaddressing.xsd"/>
      ...
    </schema>
  </types>
  ...
</definitions>
```

The original copy of the `wsaddressing.xsd` schema file is located in the `ArtixInstallDir/artix/Version/schemas` directory.

### router.wsdl file contents

For example, if the router contract contains a single port type, the contents of `router.wsdl` would have the following outline:

```
<?xml version="1.0" encoding="UTF-8"?>
<definitions name="" targetNamespace="TargetNamespaceURI"
  xmlns="http://schemas.xmlsoap.org/wsdl/"
  xmlns:corba="http://schemas.iona.com/bindings/corba"
  xmlns:corbatm="http://schemas.iona.com/typemap/corba/cdr_over_iiop.idl"
  xmlns:wsa="http://www.w3.org/2005/08/addressing"
  xmlns:soap="http://schemas.xmlsoap.org/wsdl/soap/"
  xmlns:http-conf="http://schemas.iona.com/transports/http/configuration"
  xmlns:ns1="http://schemas.iona.com/routing"
  xmlns:tns="TargetNamespaceURI"
  xmlns:xsd="http://www.w3.org/2001/XMLSchema"
  xmlns:xsd1="http://schemas.iona.com/idltypes/cdr_over_iiop.idl">
  <types>
    ...
  </types>
  <message name="..." />
  ...

  <portType name="PortTypeName">
    ...
  </portType>
```

```

<binding name="<CORBABindingName>"
         type="tns:<PortTypeName>">
  ...
</binding>

<binding name="<SOAPBindingName>"
         type="tns:<PortTypeName>">
  ...
</binding>

<service name="<CORBAServiceName>">
  ...
</service>

<service name="<SOAPServiceName>">
  ...
</service>

<ns1:route name="route_0">
  <ns1:source      service="tns:<SOAPServiceName>"
                  port="<SOAPPortName>" />
  <ns1:destination service="tns:<CORBAServiceName>"
                  port="<CORBAPortName>" />
</ns1:route>
</definitions>

```

## Generate the client contract

The client WSDL contract is a modified copy of the router contract containing only those details of the contract that are relevant to the client. To generate the client contract, perform the following steps:

1. Copy the `router.wsdl` file to `client.wsdl`.
2. Edit the `client.wsdl` file to remove redundant elements. That is, you should remove the following:
  - ◆ CORBA binding elements.
  - ◆ CORBA service elements.
  - ◆ route elements.

You could also optionally remove some of the redundant namespace definitions, such as `corba`, `corbatm`, and `ns1`.

## client.wsdl file contents

For example, if the client contract contains a single port type, the contents of `client.wsdl` would have the following outline:

```

<?xml version="1.0" encoding="UTF-8"?>
<definitions name="" targetNamespace="TargetNamespaceURI"
  xmlns="http://schemas.xmlsoap.org/wsdl/"
  xmlns:corba="http://schemas.ionas.com/bindings/corba"
  xmlns:corbatm="http://schemas.ionas.com/typemap/corba/cdr_over_iio
  p.idl"
  xmlns:wsa="http://www.w3.org/2005/08/addressing"
  xmlns:soap="http://schemas.xmlsoap.org/wsdl/soap/"
  xmlns:http-conf="http://schemas.ionas.com/transport/http/configu
  ration"
  xmlns:ns1="http://schemas.ionas.com/routing"
  xmlns:tns="TargetNamespaceURI"
  xmlns:xsd="http://www.w3.org/2001/XMLSchema"
  xmlns:xsd1="http://schemas.ionas.com/idltypes/cdr_over_iiop.idl">
  <types>
    ...
  </types>
  <message name="..."/>
  ...

  <portType name="<PortTypeName>">
    ...
  </portType>

  <binding name="<SOAPBindingName>"
    type="tns:<PortTypeName>">
    ...
  </binding>

  <service name="<SOAPServiceName>">
    ...
  </service>
</definitions>

```

---

# Embedding Artix in a CORBA Service

---

## Overview

If you want to expose an Orbix 6 CORBA server as a Web service, you have the option of embedding Artix directly in the CORBA server.

This embedding is possible because Artix and Orbix are both built using the same framework: IONA's Adaptive Runtime Technology (ART). Using the ART framework, it is possible to run Artix and Orbix in the same process just by loading the appropriate set of plug-ins needed by each product.

---

## In this section

This section contains the following subsections:

<a href="#">Embedded Router Scenario</a>	<a href="#">page 62</a>
<a href="#">Embedding a Router in the CORBA Server</a>	<a href="#">page 64</a>

## Embedded Router Scenario

### Overview

Figure 11 shows an overview of an Artix router embedded in a CORBA server. In this scenario, the CORBA service is exposed as a Web service that supports SOAP over HTTP. The embedded router is responsible for converting incoming SOAP/HTTP requests into colocated requests on the CORBA server. Any replies from the CORBA server are then converted into SOAP/HTTP replies by the router and sent back to the client.

**Note:** Embedding an Artix router is an option that is *only* available to Orbix 6 based CORBA applications. In general, the most straightforward way to build these applications is to use the Orbix libraries included with the Artix product. If you need to link with libraries taken directly from an Orbix distribution, you must take care to ensure that these libraries are binary compatible with Artix.

Figure 11: Artix Router Embedded in a CORBA Server

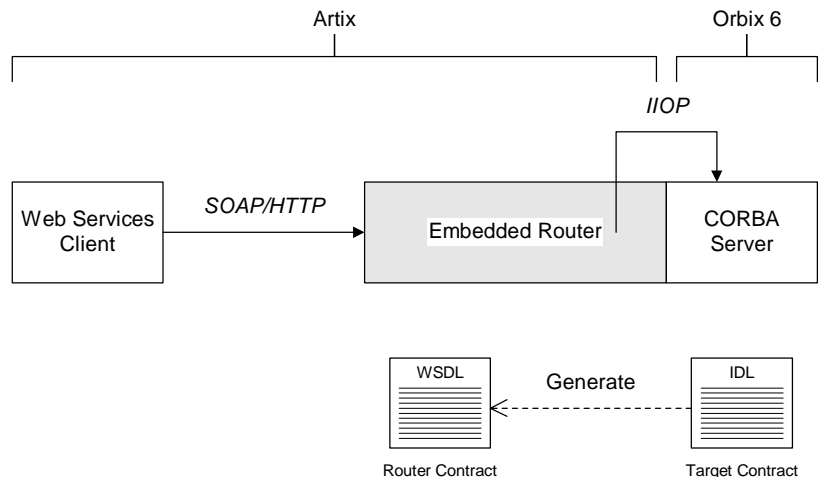

---

**Modifications to CORBA server**

The following changes must be made to the CORBA server to embed the Artix router:

- Code changes—*No*.
- Re-compilation—*No*.
- Configuration—modify the Orbix configuration file.

---

**Elements required for this scenario**

The following elements are required to implement this scenario:

- WSDL contract for clients.
- WSDL contract for the embedded router.
- Modified Orbix configuration file for the CORBA server.

---

## Embedding a Router in the CORBA Server

---

### Overview

This section describes how to embed a router in a CORBA server. The embedded router enables the CORBA server to receive requests from a SOAP/HTTP Web services client. The following steps are described:

- [Convert IDL to WSDL](#).
- [Deploy the requisite WSDL files](#).
- [Edit the Artix configuration](#).

---

### Convert IDL to WSDL

Use the Artix utilities to generate two WSDL files, `router.wsdl` and `client.wsdl`, from the CORBA server's IDL interface. For details of how to convert the IDL file to WSDL, see [“Converting IDL to WSDL” on page 52](#).

---

### Deploy the requisite WSDL files

Deploy the following WSDL files on the CORBA server host:

- `router.wsdl`—the router contract, which describes the route for converting SOAP/HTTP requests into CORBA requests.
- `wsaddressing.xsd`—the schema that defines the `wsa:EndpointReferenceType` data type, which Artix uses to represent object references.

The WS-Addressing schema is usually (but not always) required on the server side. If your IDL does not pass object endpoint references as parameters or return values, however, you do not need to deploy this file.

---

### Edit the Artix configuration

Given that your CORBA server is configured by a particular configuration scope, `orbix_srvr_with_embedded_router`, [Example 3](#) shows how to modify the server configuration to embed an Artix router.

#### **Example 3:** *Artix Configuration Suitable for an Embedded Artix Router*

```
# Artix Configuration File

orbix_srvr_with_embedded_router {
    ...

    # Modified configuration required for embedded router:
```



**Example 3:** *Artix Configuration Suitable for an Embedded Artix Router*

```

#
1 orb_plugins = [..., "ws_orb", "soap", "at_http", "routing",
  "bus_loader"];
2 binding:client_binding_list = ["OTS+GIOP+IIOP", "GIOP+IIOP"];
3
  plugins:routing:wSDL_url="../../etc/router.wSDL";
4
  plugins:ws_orb:shlib_name = "it_ws_orb";
  plugins:soap:shlib_name = "it_soap";
  plugins:http:shlib_name = "it_http";
  plugins:at_http:shlib_name = "it_at_http";
  plugins:routing:shlib_name = "it_routing";
  plugins:bus_loader:shlib_name = "it_bus_loader";
5
  share_variables_with_internal_orb = "false";
};

```

The preceding Artix configuration can be explained as follows:

1. Edit the ORB plug-ins, adding the requisite Artix plug-ins to the list. In this example, the following plug-ins are needed:
  - ◆ `ws_orb` plug-in—enables the router to send and receive CORBA messages.
  - ◆ `soap` plug-in—enables the router to send and receive SOAP messages.
  - ◆ `at_http` plug-in—enables the router to send and receive messages over the HTTP transport.
  - ◆ `routing` plug-in—contains the core of the Artix router.
  - ◆ `bus_loader` plug-in—triggers the Artix Bus initialization step. This plug-in is needed only when you are loading Artix plug-ins into a non-Artix application.

**Note:** In Artix 3.0, Artix plug-ins were refactored to cleanly separate the ORB initialization step from the Artix Bus initialization step. Usually, in an Artix application, `IT_Bus::init()` triggers the Bus initialization step. In this example, however, the CORBA server never calls `IT_Bus::init()`. Therefore, the `bus_loader` plug-in is needed to finish the initialization of the Artix plug-ins.

If you plan to use other bindings and transports, you might need to add some other Artix plug-ins instead.

2. The Artix embedded router is *not* compatible with the `POA_Colloc` interceptor. Therefore you must edit the server's `binding:client_binding_list` entry to remove any bindings containing the `POA_Colloc` interceptor.

For example, if the client binding list is defined as follows:

```
binding:client_binding_list =
    ["OTS+POA_Colloc", "POA_Colloc", "OTS+GIOP+IIOP", "GIOP+IIOP"];
```

You would replace it with the following list:

```
binding:client_binding_list = ["OTS+GIOP+IIOP", "GIOP+IIOP"];
```

**Note:** If the `binding:client_binding_list` variable does not appear explicitly in the server's configuration scope, try to find it in the next enclosing scope (or the scope that is nearest to the server's configuration scope) and copy it into the server's scope.

If you do not purge the `POA_Colloc` entries from the client binding list, clients that attempt to access the server through the router will receive a `CORBA::UNKNOWN` exception.

3. The `plugins:routing:wSDL_url` setting specifies the location of the router WSDL contract (see [“Converting IDL to WSDL” on page 52](#)). The URL can be a relative filename (as here) or a general `file: URL`.
4. In order for Orbix to load the Artix plug-ins, for each plug-in you must specify the *root name* of the shared library (or DLL on Windows) that contains the plug-in code. The requisite `plugins:<plugin_name>:shlib_name` entries can be copied from the root scope of the Artix configuration file, `artix.cfg`. You can also specify additional configuration settings for the Artix plug-ins at this point (see the *Artix Configuration Reference* for more details).
5. In certain circumstances, Orbix creates an internal ORB instance (for example, during initialization). To prevent the settings from the current scope being used by the internal ORBs—specifically, to prevent the internal ORB from loading Artix plug-ins—you should set the `share_variables_with_internal_orb` configuration variable to `false`.



---

# Exposing an Orbix 3.3 or Non-Orbix Service as a Web Service

## Overview

---

If you want to expose an Orbix 3.3 or non-Orbix CORBA server as a Web service, it is generally necessary to deploy a standalone Artix router that acts as a bridge between Web services clients and the CORBA server. Using a standalone router is a non-intrusive integration approach that should work with any CORBA back-end.

---

## In this section

This section contains the following subsections:

<a href="#">Standalone SOAP-to-CORBA Router Scenario</a>	<a href="#">page 69</a>
--	-------------------------

<a href="#">Configuring and Running a Standalone SOAP-to-CORBA Router</a>	<a href="#">page 71</a>
---	-------------------------

---

## Standalone SOAP-to-CORBA Router Scenario

---

### Overview

Figure 12 shows an overview of a standalone router. In this scenario, the router is packaged as a standalone application, which acts as a bridge between the Web services client and the CORBA server. The standalone router is responsible for converting incoming SOAP/HTTP requests into outgoing requests on the CORBA server. Replies from the CORBA server are converted into SOAP/HTTP replies by the router and sent back to the client.

**Figure 12:** *Standalone Artix Router*

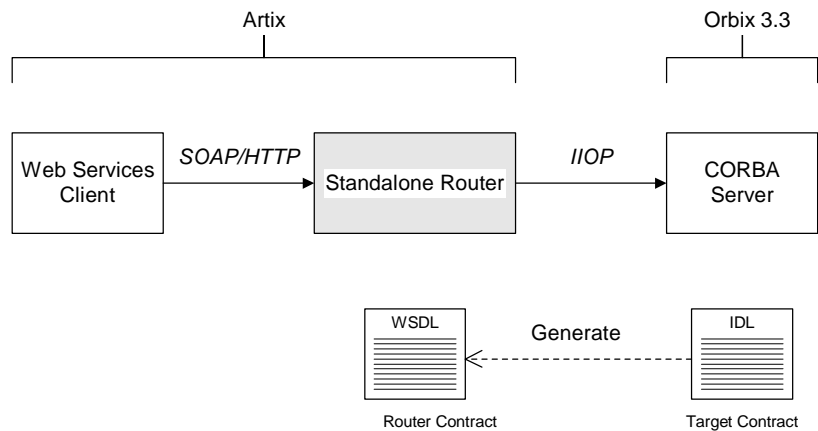

### Container

The Artix container, `it_container`, is an application that can be used to run any of the standard Artix services. The functionality of the container is determined by the plug-ins it loads at runtime.

In this scenario, the container is configured to load the `router` plug-in (along with some other plug-ins) so that it functions as a standalone router.

### Modifications to CORBA server

When using a standalone Artix router, no modifications need be made to the CORBA server.

**Elements required for this scenario**

The following elements are required to implement this scenario:

- WSDL contract for clients.
- WSDL contract for the standalone router.
- Artix configuration file for the standalone router.

---

# Configuring and Running a Standalone SOAP-to-CORBA Router

---

## Overview

This section describes how to configure and run a standalone router that acts as a bridge between a SOAP/HTTP Web services client and a CORBA server. The following steps are described:

- [Convert IDL to WSDL](#).
- [Deploy the requisite WSDL files](#).
- [Create the Artix configuration](#).
- [Run the standalone router](#).

---

## Convert IDL to WSDL

Use the Artix utilities to generate two WSDL files, `router.wsdl` and `client.wsdl`, from the CORBA server's IDL interface. For details, see ["Converting IDL to WSDL" on page 52](#).

---

## Deploy the requisite WSDL files

Deploy the following WSDL files on the standalone router host:

- `router.wsdl`—the router contract, which describes the route for converting SOAP/HTTP requests into CORBA requests.
- `wsaddressing.xsd`—the schema that defines the `wsa:EndpointReferenceType` data type, which Artix uses to represent object references.

The WS-Addressing schema is usually (but not always) required on the server side. If your IDL does not pass object references as parameters or return values, however, you do not need to deploy this file.

---

## Create the Artix configuration

[Example 4](#) shows a suitable configuration for a standalone router that maps incoming SOAP/HTTP requests to outgoing CORBA requests.

### Example 4: *Artix Configuration Suitable for a Standalone Artix Router*

```
# Artix Configuration File

standalone_router {
    # Configuration for standalone router:
    #
1   orb_plugins = ["xmlfile_log_stream", "iiop_profile", "giop",
                "iiop", "ws_orb", "soap", "at_http", "routing"];
```

**Example 4:** *Artix Configuration Suitable for a Standalone Artix Router*

```

2     plugins:routing:wSDL_url="../../etc/router.wSDL";
3
3     plugins:ws_orb:shlib_name = "it_ws_orb";
    plugins:soap:shlib_name = "it_soap";
    plugins:http:shlib_name = "it_http";
    plugins:at_http:shlib_name = "it_at_http";
    plugins:routing:shlib_name = "it_routing";

4     # Uncomment these lines for interoperability with Orbix 3.3
    #policies:giop:interop_policy:negotiate_transmission_codecset
    = "false";
    #policies:giop:interop_policy:send_principal = "true";
    #policies:giop:interop_policy:send_locate_request = "false";
};

```

The preceding Artix configuration can be explained as follows:

1. Edit the ORB plug-ins, adding the requisite Artix plug-ins to the list. In this example, the following plug-ins are needed:
  - ◆ `xmlfile_log_stream` plug-in—enables logging to an XML file.
  - ◆ `iiop_profile`, `giop`, and `iiop` plug-ins—enables the IIOP protocol (used by CORBA).
  - ◆ `ws_orb` plug-in—enables the router to send and receive CORBA messages.
  - ◆ `soap` plug-in—enables the router to send and receive SOAP messages.
  - ◆ `at_http` plug-in—enables the router to send and receive messages over the HTTP transport.
  - ◆ `routing` plug-in—contains the core of the Artix router.

If you plan to use other bindings and transports, you might need to add some other Artix plug-ins instead.
2. The `plugins:routing:wSDL_url` setting specifies the location of the router WSDL contract (see [“Converting IDL to WSDL” on page 52](#)). The URL can be a relative filename (as here) or a general `file:` URL.



3. To load the Artix plug-ins, you must specify the *root name* of the shared library (or DLL on Windows) that contains the plug-in code. The requisite `plugins:<plugin_name>:shlib_name` entries can be copied from the root scope of the Artix configuration file, `artix.cfg`.  
You can also specify additional plug-in configuration settings at this point (see the *Artix Configuration Reference* for more details).
4. If the router needs to integrate with an Orbix 3.3 CORBA server, you should uncomment these lines to enable interoperability. For more details about these configuration settings, see the *Artix Configuration Reference*.

**Note:** These interoperability settings might also be useful for integrating with other third-party ORB products. See the *Artix Configuration Reference* for more details.

---

### Run the standalone router

Run the standalone router by invoking the container, `it_container`, passing the router's ORB name as a command-line parameter (the ORB name is identical to the name of the router's configuration scope).

For example, to run the router configured in [Example 4 on page 71](#), enter the following at a command prompt:

```
it_container -ORBname standalone_router
```



# CORBA-to-CORBA Routing

*This chapter describes some special routing options that are available when the source endpoint and the destination endpoint in a route are both based on the CORBA binding.*

---

## **In this chapter**

This chapter discusses the following topics:

[Bypassing the Router](#)

page 76

---

# Bypassing the Router

---

## Overview

Specifically for the CORBA binding, the Artix router supports an option to redirect incoming client connections so that the clients connect directly to the target server, bypassing the router. This option is only available, if both the client and the target server are CORBA-based. Bypassing the router enables you to achieve optimum efficiency for a CORBA-to-CORBA route, but this option also has some interactions with other router features.

---

## In this section

This section contains the following subsections:

<a href="#">Basic Bypass Scenario</a>	<a href="#">page 77</a>
<a href="#">Bypass with Failover Scenario</a>	<a href="#">page 81</a>
<a href="#">Bypass with Load Balancing Scenario</a>	<a href="#">page 84</a>

## Basic Bypass Scenario

### Overview

Bypass routing is a CORBA-specific feature that exploits the *location forwarding* feature of the General Inter-ORB Protocol (GIOP). Location forwarding is based on specific GIOP message types, which enable CORBA services to redirect incoming connections to alternative destinations. [Figure 13](#) gives an overview of a basic bypass routing scenario.

**Figure 13:** Basic Bypass Routing Scenario

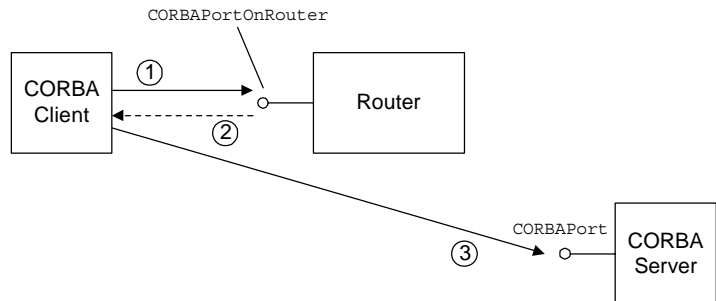

### Scenario steps

The basic bypass routing scenario shown in [Figure 13](#) can be described as follows:

1. The CORBA client sends a GIOP request message to the `CORBAPortOnRouter` endpoint.
2. The router sends a location forward reply (a special reply type defined by GIOP), which contains the interoperable object reference (IOR) for the destination endpoint on the target server.

**Note:** Internally, the router converts the address of the destination endpoint to an IOR using the `CORBA::ORB::string_to_object()` function. This affects the semantics of connection establishment.

For example, if the destination endpoint is specified as a `corbaname` URL, the router would implicitly resolve the name to an IOR (by contacting a CORBA naming service) before sending the location forward reply.

3. The CORBA client uses the received IOR to open a connection *directly* to the destination endpoint on the target server. The client now sends its request messages directly to the destination endpoint on the target.

**Note:** This step might also involve sending an additional location forward message. For example, if the destination endpoint is an Orbix server with a `plain_text_key` plug-in, the server might need to look up the incoming object key in the `plain_text_key` plug-in's registry to obtain the complete IOR. This IOR would then be sent back to the client inside a location forward reply.

---

### Interactions with other features

Bypass routing interacts with various other router features, as follows:

- [Effect on pass-through.](#)
- [Effect on security.](#)
- [Incompatibility with fanout.](#)
- [Incompatibility with content-based routing.](#)
- [Incompatibility with transport attributes.](#)
- [Unsuitability for connection concentrator.](#)

---

### Effect on pass-through

Bypass routing and pass-through routing can be enabled simultaneously. If the route is CORBA only (that is, the binding types for the source and destination endpoints are both CORBA), bypass routing takes priority. For non-CORBA binding types, pass-through routing is used.

---

### Effect on security

When bypass routing is enabled, you must ensure that the CORBA client is appropriately configured for opening a secure connection *directly* to the destination endpoint.

It is important also to understand that the router does not provide any protection for the destination endpoint. The CORBA server on the far side of the router must be independently capable of enforcing the level of security that it requires.

---

**Incompatibility with fanout**

Bypass routing is *not* compatible with fanout routes (which can be enabled by setting the `multiRoute` attribute to `fanout` in the `routing:route` element). A *fanout route* denotes a route where each incoming request message propagates to multiple recipients on the destination side of the route.

If fanout is enabled, the router would ignore the bypass setting and implement fanout instead.

---

**Incompatibility with content-based routing**

Bypass routing is *not* compatible with content-based routing (which can be configured using the `routing:query` element in the router contract).

If content-based routing is enabled, the router would ignore the bypass setting and implement content-based routing instead.

---

**Incompatibility with transport attributes**

Bypass routing is *not* compatible with routes defined using transport attributes (which can be configured using the `routing:transportAttribute` element in the router contract). Transport attributes enable you to specify a route based on the values set in the transport attributes in the message headers.

If transport attributes based routing is enabled, the router would ignore the bypass setting and implement transport attributes based routing instead.

---

**Unsuitability for connection concentrator**

A *connection concentrator* is a deployment pattern, where multiple clients connect to the same source endpoint on a router, but there is only a single connection from the router to the destination endpoint. This pattern enables you to reduce the number of connections made to the destination endpoint.

It does not make sense to use the bypass feature with a connection concentrator, because all of the client connections would end up going directly to the destination endpoint.

---

## Configuring router bypass

To enable router bypass, add the following setting to the router's configuration:

```
# Artix Configuration File
bypass_router
{
    plugins:routing:use_bypass = "true";
    ...
};
```

The default is `false`.

---

## Sample route

[Example 5](#) shows an example of a basic bypass route that listens for connection attempts on the `CORBAPortOnRouter` endpoint and then forwards the connections on to the `CORBAPort` endpoint.

### Example 5: *Sample Bypass Route*

```
<definitions name="" targetNamespace="TargetNamespaceURI"
...
xmlns:tns="TargetNamespaceURI"
xmlns:ns1="http://schemas.ionas.com/routing"
...>
...
<ns1:route name="pass_through_route">
    <ns1:source      service="tns:CORBAServiceOnRouter"
                    port="CORBAPortOnRouter"/>
    <ns1:destination service="tns:CORBAService"
                    port="CORBAPort"/>
</ns1:route>
</definitions>
```



## Bypass with Failover Scenario

### Overview

Bypass routing can be combined with the router failover feature (which can be enabled by setting `multiRoute` to `failover` in the `routing:route` element). In this case, failover support requires cooperation between the CORBA client and the router. [Figure 14](#) gives an overview of a bypass routing with failover scenario.

**Figure 14:** *Bypass Routing with Failover Scenario*

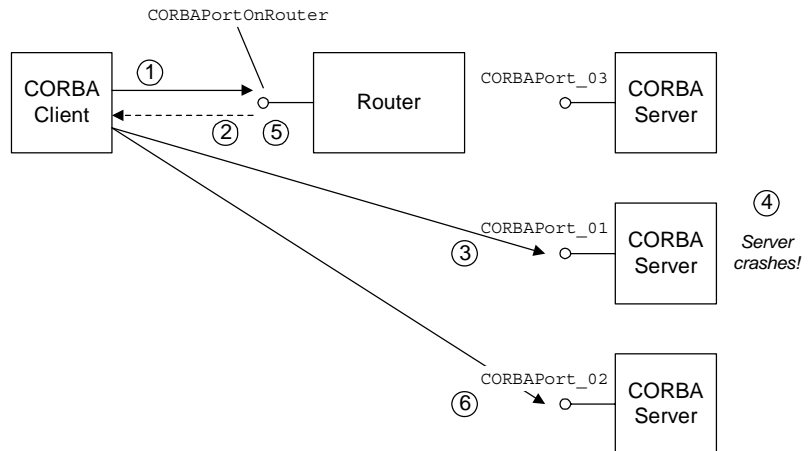

### Scenario steps

The bypass routing scenario shown in [Figure 14](#) can be described as follows:

1. The CORBA client sends a GIOP request message to the `CORBAPortOnRouter` endpoint.
2. The router sends a location forward reply, which contains the IOR for one of the destination endpoints in the failover cluster—for example, `CORBAPort_01`.
3. The CORBA client uses the received IOR to open a connection *directly* to the `CORBAPort_01` destination endpoint.

4. If the target server crashes, the CORBA client transparently falls back to the `CORBAPortOnRouter` endpoint.
5. The router again sends a location forward reply, which contains the IOR for another of the destination endpoints in the failover cluster—for example, `CORBAPort_02`.
6. The CORBA client uses the received IOR to open a connection directly to the `CORBAPort_02` destination endpoint.

### Configuring bypass with failover

To enable bypass routing with failover, add the following setting to the router's configuration:

```
# Artix Configuration File
bypass_router
{
    plugins:routing:use_bypass = "true";
    ...
};
```

### Sample route

[Example 6](#) shows an example of a bypass route with failover enabled. There are three alternative destination endpoints in this failover cluster: `CORBAPort_01`, `CORBAPort_02`, and `CORBAPort_03`. The `multiRoute` attribute must be set to `failover`.

**Example 6:** *Sample Bypass Route with Failover*

```
<definitions name="" targetNamespace="TargetNamespaceURI"
...
xmlns:tns="TargetNamespaceURI"
xmlns:ns1="http://schemas.ionac.com/routing"
...>
...
<ns1:route name="pass_through_route"
    multiRoute="failover">
    <ns1:source      service="tns:CORBAServiceOnRouter"
                    port="CORBAPortOnRouter"/>
    <ns1:destination service="tns:CORBAService_01"
                    port="CORBAPort_01"/>
    <ns1:destination service="tns:CORBAService_02"
                    port="CORBAPort_02"/>
    <ns1:destination service="tns:CORBAService_03"
                    port="CORBAPort_03"/>
</ns1:route>
</definitions>
```

## Bypass with Load Balancing Scenario

### Overview

Bypass routing can be combined with the router load balancing feature (which can be enabled by setting `multiRoute` to `loadBalance` in the `routing:route` element). When load balancing is combined with bypass routing, the router has the following characteristics:

- Incoming client connections are load-balanced using a round-robin algorithm.
- Load balancing is implemented *per-connection* rather than *per-operation*. That is, once a client is assigned to a particular destination endpoint, it sends all of its requests to that endpoint.
- Failover is also supported in load balancing scenario. That is, if a server fails, the client is forwarded on to the next healthy server in the cluster (just as in the failover scenario).

Figure 15 gives an overview of a bypass routing with load balancing scenario.

**Figure 15:** *Bypass Routing with Load Balancing Scenario*

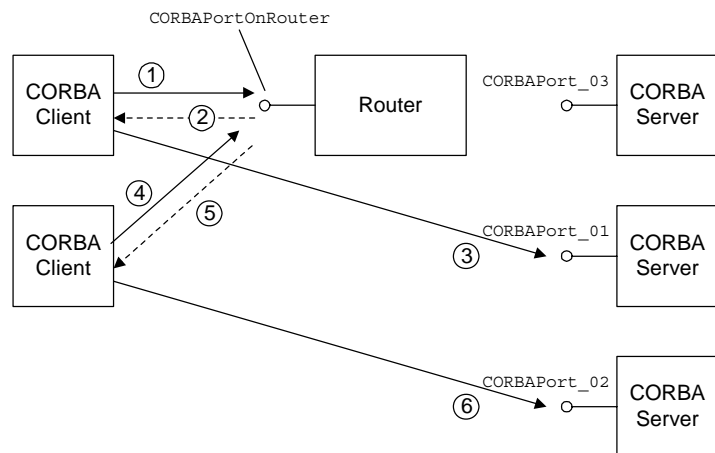

**Scenario steps**

---

The bypass routing scenario shown in [Figure 15](#) can be described as follows:

1. The first CORBA client sends a GIOP request message to the `CORBAPortOnRouter` endpoint.
  2. The router sends a location forward reply, which contains the IOR for one of the destination endpoints in the load balancing cluster—for example, `CORBAPort_01`.
  3. The first CORBA client uses the received IOR to open a connection *directly* to the `CORBAPort_01` destination endpoint.
  4. The second CORBA client sends a GIOP request message to the `CORBAPortOnRouter` endpoint.
  5. The router sends a location forward reply, which contains the IOR for the next destination endpoint in the load balancing cluster—for example, `CORBAPort_02`. The router load balancing uses a round-robin algorithm to assign destination endpoints to successive clients.
  6. The second CORBA client uses the received IOR to open a connection *directly* to the `CORBAPort_02` destination endpoint.
- 

**Configuring bypass with load balancing**

To enable bypass routing with load balancing, add the following setting to the router's configuration:

```
# Artix Configuration File
bypass_router
{
    plugins:routing:use_bypass = "true";
    ...
};
```

**Sample route**

[Example 7](#) shows an example of a bypass route with load balancing enabled. There are three alternative destination endpoints in the load balancing cluster: CORBAPort\_01, CORBAPort\_02, and CORBAPort\_03. The `multiRoute` attribute must be set to `loadBalance`.

**Example 7:** *Sample Bypass Route with Load Balancing*

```
<definitions name="" targetNamespace="TargetNamespaceURI"
...
xmlns:tns="TargetNamespaceURI"
xmlns:ns1="http://schemas.ionac.com/routing"
...>
...
<ns1:route name="pass_through_route"
    multiRoute="loadBalance">
    <ns1:source      service="tns:CORBAServiceOnRouter"
                    port="CORBAPortOnRouter"/>
    <ns1:destination service="tns:CORBAService_01"
                    port="CORBAPort_01"/>
    <ns1:destination service="tns:CORBAService_02"
                    port="CORBAPort_02"/>
    <ns1:destination service="tns:CORBAService_03"
                    port="CORBAPort_03"/>
</ns1:route>
</definitions>
```

# Integrating the CORBA Naming Service with Artix

*In a mixed Artix/CORBA system, it is often necessary for an Artix application to retrieve an object reference from the CORBA Naming Service. Artix supports a relatively simple configuration option for binding a name to or resolving a name from the CORBA Naming Service: simply set the location attribute of <corba:address> to be a corbaname URL.*

---

**In this chapter**

This chapter discusses the following topics:

<a href="#">How an Artix Client Resolves a Name</a>	page 88
<a href="#">How an Artix Server Binds a Name</a>	page 92
<a href="#">Artix Client Integrated with a CORBA Server</a>	page 95

## How an Artix Client Resolves a Name

### Overview

Figure 16 shows a typical scenario where an Artix client might need to resolve a name from the CORBA Naming Service. The Artix client, which is configured to have a `corba` binding, connects to a pure CORBA server using the CORBA Naming Service.

To configure the client to resolve the name, you need to specify a `corbaname` URL in the `corba:address` element within a `service`. No programming is required. There are, however, some prerequisites settings in the Artix configuration file that are also required in order to enable the client to find the CORBA Naming Service.

**Figure 16:** Artix Client Resolving a Name from the Naming Service

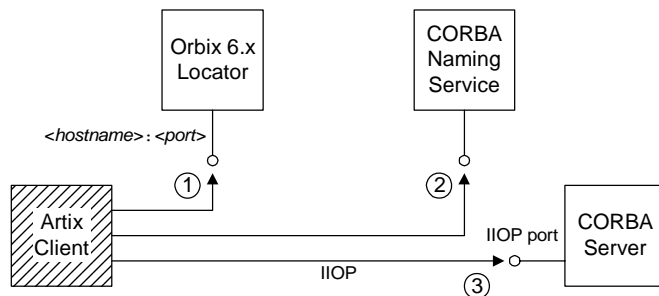



**Resolving steps for Orbix 6.x**

Artix performs the following steps to resolve a name in the Orbix 6.x CORBA Naming Service (as shown in [Figure 16](#)):

Step	Action
1	The Artix client sends a GIOP <i>LocateRequest</i> message to the Orbix locator, whose hostname and port is specified in the Artix configuration file. The <i>LocateRequest</i> reply gives the location of the CORBA Naming Service.
2	The Artix client contacts the CORBA Naming Service to resolve the name specified in the WSDL <i>corba:address</i> element.
3	The object reference returned from the naming service is used to contact the CORBA server.

**Prerequisites**

Before configuring the client's WSDL contract to resolve a name from the CORBA Naming Service, you must edit the Artix configuration file to provide some details about the remote naming service. The configuration settings depend on the kind of ORB you are interoperating with, as follows:

**Interoperating with Orbix 6.x, ASP 5.x**

In your Artix configuration file, *ArtixInstallDir/artix/Version/etc/domains/artix.cfg*, add the following lines to the configuration scope used by the Artix client:

```
# Artix Configuration File
artix_client_of_Orbix_6 {
    ...
    initial_references:NameService:reference = "corbaloc::<hostname>:<port>/NameService";
    url_resolvers:corbaname:plugin="naming_resolver";
    plugins:naming_resolver:shlib_name="it_naming";
};
```

Where `<hostname> : <port>` is the host and port where the Orbix locator service is running. By default, Orbix 6.x configures the locator `<port>` to be 3075, but you might need to check the `plugins:locator:iiop:port` setting in your Orbix 6.x configuration file if you are not sure of the value.

**Note:** The *Orbix locator service* is responsible for keeping track of running Orbix services. It is completely unrelated to the Artix locator service.

### Interoperating with Orbix 3.3

In your Artix configuration file, `ArtixInstallDir/artix/Version/etc/domains/artix.cfg`, add the following lines to the configuration scope used by the Artix client:

```
# Artix Configuration File
artix_client_or_Orbix_33 {
    ...
    initial_references:NameService:reference = "IOR:000000.....";

    policies:giop:interop_policy:negotiate_transmission_codeset = "false";
    policies:giop:interop_policy:send_principal = "true";
    policies:giop:interop_policy:send_locate_request = "false";
};
```

The stringified IOR shown in the preceding example, `IOR:000000...`, can be obtained from the 3.3.x Naming Service by starting the NS with the `-I <filename>` switch and copying the IOR from the `<filename>` into the configuration file. When using the `IOR:` format, you do not need to load the `naming_resolver` plug-in (the `naming_resolver` is needed only to resolve corbaloc URLs).

### Interoperating with other ORBs

Generally, the approach used for interoperating with Orbix 3.3 (initializing `initial_references:NameService:reference` with the value of the naming service's IOR) should work for just about any third-party ORB product. You might need to modify some of the GIOP interoperability policies, however. For more details, consult the *Artix Configuration Reference*.

**Configure the WSDL service**

To configure an Artix client to resolve a name in the CORBA Naming Service, use the `corbaname` URL format in the `<corba:address>` tag, as follows:

```
<service name="CORBAService">
  <port binding="tns:CORBABinding" name="CORBAPort">
    <corba:address location="corbaname:rir:/NameService#StringName"/>
  </port>
</service>
```

Where *StringName* is the name that you want to resolve, specified in the standard CORBA Naming Service string format. For example, if you have a name with `id` equal to `ArtixTest` and `kind` equal to `obj`, contained within a naming context with `id` equal to `Foo` and `kind` equal to `ctx`, the `corbaname` URL would be expressed as:

```
corbaname:rir:/NameService#Foo.ctx/ArtixTest.obj
```

In other words, the general format of a string name is as follows:

```
<id>[.<kind>]/<id>[.<kind>]/...
```

## How an Artix Server Binds a Name

### Overview

Figure 17 shows a typical scenario where an Artix server might need to bind a name to the CORBA Naming Service. In the context of the CORBA Naming Service, *binding a name* means that the server advertises the location of a CORBA object by storing an object reference against a name in the naming service.

To configure the server to bind the name, you need to specify a `corbaname` URL in the `corba:address` element within a `service` (exactly the same configuration as an Artix client). When the Artix server activates the `<service>` or `<port>`, by registering with the Artix Bus, the runtime automatically binds the name in the naming service.

**Figure 17:** Artix Server Binding a Name to the Naming Service

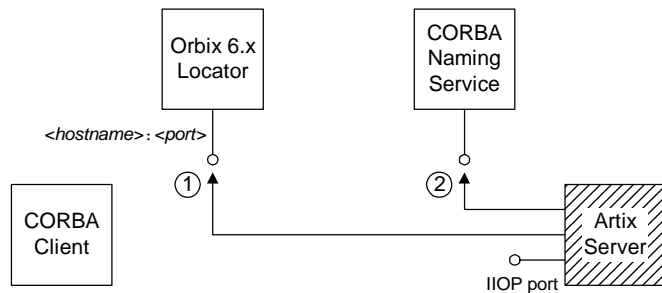

**Binding steps for Orbix 6.x**

Artix performs the following steps to bind a name in the Orbix 6.x CORBA Naming Service (as shown in [Figure 17](#)):

Step	Action
1	The Artix server sends a GIOP <i>LocateRequest</i> message to the Orbix locator, whose hostname and port is specified in the Artix configuration file. The <i>LocateRequest</i> reply gives the location of the CORBA Naming Service.
2	The Artix server contacts the CORBA Naming Service to bind the name specified in the WSDL <code>corba:address</code> element.

**Prerequisites**

The prerequisites for an Artix server that binds a name to the CORBA Naming Service are identical to the prerequisites for an Artix client that resolves a name—see [“Prerequisites” on page 89](#) for details.

**Configure the WSDL service**

To configure an Artix server to bind a name in the CORBA Naming Service, use the `corbaname` URL format in the `<corba:address>` tag, as follows:

```
<service name="CORBAService">
  <port binding="tns:CORBABinding" name="CORBAPort">
    <corba:address location="corbaname:rir:/NameService#StringName"/>
  </port>
</service>
```

Where *StringName* is the name that you want to resolve, specified in the standard CORBA Naming Service string format.

This is identical to the configuration for an Artix client, but the server treats this configuration setting differently. When an Artix server activates a service containing a `corbaname` URL, the server automatically binds the given *StringName* into the CORBA naming service.

## Binding semantics

---

The automatic binding performed by an Artix server when it encounters a `corbaname` URL has the following characteristics:

- The binding operation has the semantics of the `CosNaming::NamingContext::rebind()` IDL operation. That is, the bind operation either creates a new binding or clobbers an existing binding of the same name.
- If some of the naming contexts in the *StringName* compound name do not yet exist in the naming service, the Artix server does *not* create the missing contexts.

For example, if you try to bind a *StringName* with the value `Foo/Bar/SomeName` where neither the `Foo` nor `Foo/Bar` naming contexts exist yet, the Artix server will not bind the given name. You would need to create the naming contexts manually prior to running the Artix server (for example, in Orbix 6.x you could issue the command `itadmin ns newnc NameContext`).

---

# Artix Client Integrated with a CORBA Server

---

## Overview

This section presents an example scenario of an Artix client integrated with a CORBA server, where the client obtains a CORBA object reference through the CORBA Naming Service.

In summary, the scenario works as follows:

- A CORBA Naming Service from an ORB product (presumed to be Orbix 6.x) is assumed to be running.
- As the CORBA server starts up, it uses the `CosNaming::NamingContext` IDL interface to bind a name to the naming service.
- When the Artix client starts up, the Artix runtime reads the client's WSDL contract, extracts a `corbaname` URL and contacts the naming service to resolve the `corbaname` URL.

## In this section

This section contains the following subsections:

<a href="#">CORBA Server Implementation</a>	<a href="#">page 96</a>
<a href="#">Artix Client Configuration</a>	<a href="#">page 99</a>

## CORBA Server Implementation

### Overview

The code example in this subsection shows you how a server binds a name to the root naming context of the CORBA Naming Service. This shows how a CORBA programmer can use the standard `CosNaming::NamingContext` IDL interface to bind a name.

**Note:** This is a pure CORBA example; there is no Artix programming involved here.

### CORBA server main function

[Example 8](#) shows part of the `main()` function for a CORBA server that registers a name in the CORBA Naming Service. The lines of code shown in bold bind the name, `ArtixTest`, to the root naming context.

**Example 8:** *CORBA Server that Register a Name in the Naming Service*

```
// C++
...
#include <omg/CosNaming.h>
...
int main(int argc, char* argv[])
{
    IT_TerminationHandler::set_signal_handler(sig_handler);

    try
    {
        cout << "Initializing the ORB" << endl;
        global_orb = CORBA::ORB_init(argc, argv);
        CORBA::Object_var poa_obj =
            global_orb->resolve_initial_references("RootPOA");
        PortableServer::POA_var root_poa =
            PortableServer::POA::_narrow(poa_obj);
        assert(!CORBA::is_nil(root_poa));

        cout << "Creating objects" << endl;

        HWImplementation hw_servant;
        PortableServer::ObjectId_var hw_oid =
            root_poa->activate_object(&hw_servant);
```



**Example 8:** CORBA Server that Register a Name in the Naming Service

```

CORBA::Object_var ref=
root_poa->create_reference_with_id(
    hw_oid,
    _tc_HelloWorld->id()
);

// Use the simple NamingContext interface
CosNaming::NamingContext_var rootContext;

// Get a reference to the Root Naming Context.
CORBA::Object_var objVar;
objVar = global_orb->resolve_initial_references(
    "NameService"
);
rootContext = CosNaming::NamingContext::_narrow(objVar);

if (CORBA::is_nil(rootContext.in()))
{
    cerr << "_narrow returned nil" << endl;
    return 1;
}

CosNaming::Name_var tmpName = new CosNaming::Name(1);
tmpName->length(1);

tmpName[0].id = CORBA::string_dup("ArtixTest");
tmpName[0].kind = CORBA::string_dup("");
rootContext->rebind(tmpName, ref);

// Activate the POA Manager to allow requests to arrive
PortableServer::POAManager_var poa_manager =
    root_poa->the_POAManager();
poa_manager->activate();

// Give control to the ORB
//
global_orb->run();
return 0;
}
catch (CORBA::Exception& e)
{
    cout << "Error occurred: " << e << endl;
}
return 1;
}

```

**Demonstration code**

---

If you want to run this CORBA server code in a real example, you could use the following demonstration as a starting point:

*ArtixInstallDir/artix/Version/demos/transport/cdr\_over\_iiop/corba*

In the server subdirectory, there is an existing `server.cxx` mainline file that publishes the IOR by saving to a file. To change the server to use the naming service, you can replace the existing server `main()` function with the code shown in [Example 8 on page 96](#).

Note the following points:

- Remember to add the include line, `#include <omg/CosNaming.hh>`, at the start of the `server.cxx` file.
- Edit the server `Makefile`, adding the `it_naming` library to the link list. For example, on Windows you would add `it_naming.lib` to the link list.
- You need a separate ORB product (for example, Orbix) to run the CORBA Naming Service. The Artix product does *not* include a CORBA Naming Service.

---

## Artix Client Configuration

---

### Overview

This subsection shows how to configure an Artix client to fetch an object reference from the CORBA Naming Service.

---

### Demonstration configuration

The configuration files referred to in this subsection are taken from the `cdr_over_iiop` demonstration and located in the following directory:

*ArtixInstallDir/artix/Version/demos/transport/cdr\_over\_iiop/etc*

The corresponding client application requires no modification. You can choose to run either a C++ version of the client:

```
cdr_over_iiop/cxx/client
```

Or a Java version of the client:

```
cdr_over_iiop/java/client
```

---

### Artix configuration file

[Example 9](#) shows the Artix configuration required for the Artix client to interoperate with the Orbix 6.x naming service.

**Example 9:** *Artix Configuration for Interoperating with Orbix 6 Naming*

```
# Artix Configuration File
include "../../../../../etc/domains/artix.cfg";

demos {
  cdr_over_iiop {
    orb_plugins = ["xmlfile_log_stream", "iiop_profile", "giop", "iiop", "ws_orb"];

    initial_references:NameService:reference = "corbaloc::localhost:3075/NameService";
    url_resolvers:corbaname:plugin = "naming_resolver";
    plugins:naming_resolver:shlib_name = "it_naming";

    corba {
      orb_plugins = ["iiop_profile", "giop", "iiop"];
    };
  };
};
```

To configure the `cdr_over_iiop` demonstration, edit the `cdr_over_iiop/etc/cdr_over_iiop.cfg` file, inserting the three lines highlighted in bold in [Example 9 on page 99](#). You might need to modify the

value of the hostname and port—this example assumes that the Orbix locator service is running on the same host as the client, `localhost`, and listening on the default port, `3075`.

**Note:** The configuration shown in [Example 9 on page 99](#) is specific to the Orbix 6.x naming service. If you use a different ORB product, you might have to set this configuration differently—see [“Prerequisites” on page 89](#) for more details.

## WSDL contract

You also need to edit the client’s WSDL contract, specifying the `location` attribute of the `corba:address` element using a `corbaname` URL.

[Example 10](#) shows the modifications you need to make to the `corba:address` element in the `cdr_over_iiop/etc/cdr_over_iiop.wsdl` contract file.

### Example 10: CORBA Address Specified as a corbaname URL

```
<definitions name="cdr_over_iiop" targetNamespace="http://www.iona.com/cdr_over_iiop"
  xmlns="http://schemas.xmlsoap.org/wsdl/"
  xmlns:corba="http://schemas.iona.com/bindings/corba"
  xmlns:corbatm="http://www.iona.com/cdr_over_iiop"
  ... >
  ...
  <service name="HelloWorldService">
    <port binding="corbatm:HelloWorldBinding" name="HelloWorldPort">
      <corba:address location="corbaname:rir:/NameService#ArtixTest"/>
    </port>
  </service>
</definitions>
```

When the client starts up, the Artix runtime automatically retrieves the CORBA object reference by resolving the name, `ArtixTest`, in the scope of the root naming context.

# Advanced CORBA Port Configuration

*This chapter describes some advanced configuration options for customizing a CORBA port on an Artix server.*

---

**In this chapter**

This chapter discusses the following topics:

<a href="#">Configuring Fixed Ports and Long-Lived IORs</a>	page 102
<a href="#">CORBA Timeout Policies</a>	page 108
<a href="#">Retrying Invocations and Rebinding</a>	page 110

---

# Configuring Fixed Ports and Long-Lived IORs

---

## Overview

Artix provides a `corba:policy` element that enables you to customize certain CORBA-specific policies for a WSDL service that acts as a CORBA endpoint. Essentially, the `corba:policy` element makes it possible to enable the following features on a CORBA endpoint:

- *Fixed IP port*—the WSDL service listens on the same IP port all the time. This is useful, for example, if the available range of IP ports is restricted or if the service must be accessible through a firewall.
- *Long-lived interoperable object references (IORs)*—the IOR remains valid even after the server is stopped and restarted.

You can configure a WSDL service to behave in one of the following ways:

- [Transient service](#).
- [Direct persistent service](#).

## Transient service

By default, a CORBA endpoint is automatically configured to be *transient*. A transient service generates IORs with the following characteristics:

- *Randomly-assigned IP port*—the IP port is assigned by the underlying operating system. Hence, the port is generally different each time the Artix server is run.
- *Short-lived IORs*—the CORBA binding generates IORs in such a way that they are guaranteed to become invalid when the server is stopped and restarted.

**Note:** In this context, *transient* is a CORBA concept which refers to the `TRANSIENT` value of the `PortableServer::LifespanPolicy`. This notion of transience should *not* be confused with the Artix notion of transience, which is concerned with registering transient servants. The two concepts are completely different.

**Direct persistent service**

---

You can optionally configure a CORBA endpoint to be *direct persistent*. A direct persistent service generates IORs with the following characteristics:

- *Fixed IP port*—you can explicitly assign the IP port by configuration. Hence, the IP port remains the same each time the Artix server is run.
- *Long-lived IORs*—the CORBA binding generates IORs in such a way that they remain valid even when the server is stopped and restarted. All of the addressing information embedded in the IOR must remain constant, in particular:
  - ◆ *IP port is fixed*—the WSDL service must be configured to listen on a fixed IP port.
  - ◆ *POA name is fixed*—the POA name is a CORBA-specific construct that identifies an endpoint.
  - ◆ *Object ID in IOR is fixed*—the Object ID is a CORBA-specific construct that identifies a particular object in a given POA instance.
  - ◆ *POA is persistent*—a prerequisite for generating long-lived IORs is that the POA must have a life span policy value of `PERSISTENT`.

### Configuring a service to be direct persistent

To configure an Artix service to be direct persistent, you must edit both the WSDL file and the Artix configuration file.

#### Editing the WSDL file

Artix enables you to set direct persistence attributes in WSDL by adding a `corba:policy` element to the WSDL service, as shown in [Example 11](#).

#### Example 11: Setting Direct Persistence Attributes in WSDL

```
<definitions name="" targetNamespace="..."
  ...
  xmlns:corba="http://schemas.ionas.com/bindings/corba"
  ...>
  ...
  <service name="CORBAServiceName">
    <port binding="tns:CORBABinding"
      name="CORBAPortName">
      <corba:address location="file:///greeter.ior"/>
      <corba:policy persistent="true"
                    poaname="FQPN"
                    serviceid="ObjectID" />
    </port>
  </service>
</definitions>
```

The `corba:policy` attributes from [Example 11](#) can be explained as follows:

- `persistent` attribute—by setting this attribute to `true`, you configure the CORBA binding to generate persistent IORs (that is, IORs that continue to be valid even after the Artix server is stopped and restarted). The default value is `false`.

**Note:** In CORBA terms, this is equivalent to setting the `PortableServer::LifespanPolicy` policy to `PERSISTENT`.

- `poaname` attribute—in CORBA terminology, a POA is an object that groups CORBA objects together (a kind of container for CORBA objects). It is necessary to set the POA name here, because the POA name is embedded in the generated IORs. The generated IORs would



not be long-lived, unless the POA name remains constant. By default, a POA name is automatically generated with the value, `{ServiceNamespace}ServiceLocalPart#PortName`.

**Note:** The POA name, *FQPN*, is a *fully-qualified POA name*. In practice, however, you can only set a simple POA name. Artix currently does not provide a way of creating a POA name hierarchy.

- `serviceid` attribute—in CORBA terminology, this attribute specifies an *Object ID* for a CORBA object. It is necessary to set the Object ID here, because the Object ID is embedded in the server-generated IOR. The Object ID must have a constant value in order for the IOR to be long-lived. By default, the underlying POA would generate a random value for the Object ID.

Artix currently allows you to set only one Object ID for each port.

**Note:** The `serviceid` attribute also implicitly sets the `PortableServer::IdAssignmentPolicy` policy to `USER_ID`. If the `serviceid` attribute is *not* set, the `PortableServer::IdAssignmentPolicy` policy defaults to `SYSTEM_ID`.

### Editing the Artix configuration file

To complete the configuration of direct persistence, you must also set some configuration variables in the relevant scope of the Artix configuration file. For example, if your Artix server uses the `artix_server` configuration scope, you would add the configuration variables as shown in [Example 12](#).

#### Example 12: Setting Direct Persistence Configuration Variables

```
# Artix Configuration File
...
artix_server {
    ...
    poa:FQPN:direct_persistent="true";
    poa:FQPN:well_known_address="WKA_prefix";
    WKA_prefix:iiop:port="IP_Port";
};
```

The configuration variables from [Example 12](#) can be explained as follows:

- `poa:FQPN:direct_persistent` variable—you must set this variable to `true`, which configures the CORBA binding to receive *direct* connections from Orbix clients. You should substitute *FQPN* with the POA name from the `poaname` attribute in the WSDL (see [Example 11 on page 104](#)).

**Note:** In CORBA terms, this is equivalent to setting the `IT_PortableServer::PersistenceModePolicy` policy to `DIRECT_PERSISTENCE`. The alternative policy value, `INDIRECT_PERSISTENCE`, is not compatible with Artix, because it would require connections to be routed through the *Orbix locator service*, which is *not* part of the Artix product.

- `poa:FQPN:well_known_address` variable—this variable defines a prefix, *WKA\_prefix*, which forms part of the variable names that configure a fixed port for the WSDL service. You should substitute *FQPN* with the POA name from the `poaname` attribute in the WSDL.
- `WKA_prefix:iiop:port` variable—this variable configures a fixed IP port for the WSDL service associated with *WKA\_prefix*.

### Fixed port configuration variables

The following IIOP configuration variables can be set for a CORBA endpoint that uses the *WKA\_prefix* prefix:

`WKA_prefix:iiop:host = "host";`

Specifies the hostname, *host*, to publish in the IIOP profile of server-generated IORs. This variable is potentially useful for multi-homed hosts, because it enables you to specify which network card the client should attempt to connect to.

`WKA_prefix:iiop:port = "port";`

Specifies the fixed IP port, *port*, on which the server listens for incoming IIOP/TLS messages. This port value is also published in the IIOP profile of generated IORs.

`WKA_prefix:iiop:listen_addr = "host";`

Restricts the IIOP/TLS listening point to listen only on the specified address, *host*. It is generally used on multi-homed hosts to limit incoming connections to a particular network interface. The default is to listen on `0.0.0.0` (which represents every network card on the host).

**Secure fixed port configuration variables**

---

Additionally, the following secure fixed port configuration variables can be set for a CORBA endpoint that uses the *WKA\_prefix* prefix:

*WKA\_prefix:iiop\_tls:host*

*WKA\_prefix:iiop\_tls:port*

*WKA\_prefix:iiop\_tls:listen\_addr*

These configuration variables function analogously to their insecure counterparts.

**Note:** These secure configuration variables will have no effect, unless the *iiop\_tls* plug-in is also loaded. It is strongly recommended that you read the *Artix Security Guide* for details of how to configure IIOP/TLS security.

---

# CORBA Timeout Policies

---

## Overview

Artix servers that expose a CORBA endpoint can be configured to use CORBA-specific timeout policies. The timeout policies described here affect GIOP transports (for example, the IIOP or IIOP/TLS transports), but do *not* have any affect on non-CORBA transports.

---

## Example

To use the timeout policies, add the relevant configuration variables to the Artix server's configuration scope in the Artix configuration file. For example, for an Artix server that uses the `artix_server` configuration scope, you can set the CORBA relative roundtrip timeout as follows:

```
# Artix Configuration File
artix_server {
    # Limit total time for an invocation to 2 seconds
    # (including time for connection and binding establishment).
    policies:relative_roundtrip_timeout = "2000";
}
```

---

## Timeout policies

You can configure the following CORBA timeout policies in your Artix configuration file:

`policies:relative_binding_exclusive_request_timeout`

Limits the amount of time allowed to deliver a request, exclusive of binding attempts. Request delivery is considered complete when the last fragment of the GIOP request is sent over the wire to the target object. This policy's value is set in millisecond units.

`policies:relative_binding_exclusive_roundtrip_timeout`

Limits the amount of time allowed to deliver a request and receive its reply, exclusive of binding attempts. The countdown begins immediately after a binding is obtained for the invocation. This policy's value is set in millisecond units.

`policies:relative_connection_creation_timeout`

Specifies how much time is allowed to resolve each address in an IOR, within each binding iteration. Defaults to 8 seconds.

An IOR can have several `TAG_INTERNET_IOP` (IIOP transport) profiles, each with one or more addresses, while each address can resolve through DNS to multiple IP addresses.

This policy applies to each IP address within an IOR. Each attempt to resolve an IP address is regarded as a separate attempt to create a connection. The policy's value is set in millisecond units.

`policies:relative_request_timeout`

Specifies how much time is allowed to deliver a request. Request delivery is considered complete when the last fragment of the GIOP request is sent over the wire to the target object. The timeout-specified period includes any delay in establishing a binding. This policy type is useful to a client that only needs to limit request delivery time. Set this policy's value in millisecond units.

No default is set for this policy; if it is not set, request delivery has unlimited time to complete.

`policies:relative_roundtrip_timeout`

Specifies how much time is allowed to deliver a request and its reply. Set this policy's value in millisecond units. No default is set for this policy; if it is not set, a request has unlimited time to complete.

The timeout countdown begins with the request invocation, and includes the following activities:

- ◆ Marshalling in/inout parameters
- ◆ Any delay in transparently establishing a binding

If the request times out before the client receives the last fragment of reply data, all received reply data is discarded. In some cases, the client might attempt to cancel the request by sending a GIOP `CancelRequest` message.

---

# Retrying Invocations and Rebinding

---

## Overview

Artix lets you configure CORBA policies that customize invocation retries and reconnection. The policies can be grouped into the following categories:

- [Retrying invocations.](#)
- [Rebinding.](#)

---

## Retrying invocations

The following configuration variables determine how the CORBA binding deals with requests that raise the `CORBA::TRANSIENT` exception with a completion status of `COMPLETED_NO`. In terms of an IIOP connection, a `TRANSIENT` exception is raised if an error occurred before or during an attempt to write to or connect to a socket.

`policies:invocation_retry:backoff_ratio`

Specifies the degree to which delays between invocation retries increase from one retry to the next. Defaults to 2.

`policies:invocation_retry:initial_retry_delay`

Specifies the amount of time, in milliseconds, between the first and second retries. Defaults to 100.

**Note:** The delay between the initial invocation and first retry is always 0.

`policies:invocation_retry:max_forwards`

Specifies the number of times an invocation message can be forwarded. Defaults to 20. To specify unlimited forwards, set to -1.

`policies:invocation_retry:max_retries`

Specifies the number of transparent reinocations attempted on receipt of a `TRANSIENT` exception. Defaults to 5.

## Rebinding

---

The following configuration variables determine how the CORBA binding deals with requests that raise the `CORBA::COMM_FAILURE` exception with a completion status of `COMPLETED_NO`. In terms of an IIOP connection, a `COMM_FAILURE` exception is raised with a completion status of `COMPLETED_NO`, if the connection went down.

`policies:rebind_policy`

Specifies the default value for the rebind policy. Can be one of the following:

- ◆ `TRANSPARENT` (*default*)
- ◆ `NO_REBIND`
- ◆ `NO_RECONNECT`

`policies:invocation_retry:max_rebinds`

Specifies the number of transparent rebinds attempted on receipt of a `COMM_FAILURE` exception. Defaults to 5.

**Note:** This setting is valid only if the effective `policies:rebind_policy` value is `TRANSPARENT`; otherwise, no rebinding occurs.





# Artix IDL-to-WSDL Mapping

*This chapter describes how the Artix IDL-to-WSDL compiler maps OMG IDL types to WSDL types and how the WSDL types are then mapped to C++ and Java.*

---

## In this appendix

This appendix discusses the following topics:

<a href="#">Introducing CORBA Type Mapping</a>	page 114
<a href="#">IDL Primitive Type Mapping</a>	page 115
<a href="#">IDL Complex Type Mapping</a>	page 119
<a href="#">IDL Module and Interface Mapping</a>	page 136

---

# Introducing CORBA Type Mapping

---

## Overview

To ensure that messages are converted into the proper format for a CORBA application to understand, Artix contracts need to unambiguously describe how data is mapped to CORBA data types.

For primitive types, the mapping is straightforward. However, complex types such as structures, arrays, and exceptions require more detailed descriptions.

---

## Unsupported types

The following CORBA types are not supported:

- Value types
- Boxed values
- Local interfaces
- Abstract interfaces
- Forward-declared interfaces

# IDL Primitive Type Mapping

## Mapping chart

Most primitive IDL types are directly mapped to primitive XML Schema types. [Table 1](#) lists the mappings for the supported IDL primitive types.

**Table 1:** *Primitive Type Mapping for CORBA Plug-in*

IDL Type	XML Schema Type	CORBA Binding Type	Artix C++ Type	Artix Java Type
any	xsd:anyType	corba:any	IT_Bus::AnyHolder	com.iona.webservices.reflect.types.AnyType
boolean	xsd:boolean	corba:boolean	IT_Bus::Boolean	boolean
char	xsd:byte	corba:char	IT_Bus::Byte	byte
string	xsd:string	corba:string	IT_Bus::String	java.lang.String
wchar	xsd:string	corba:wchar	IT_Bus::String	java.lang.String
wstring	xsd:string	corba:wstring	IT_Bus::String	java.lang.String
short	xsd:short	corba:short	IT_Bus::Short	short
long	xsd:int	corba:long	IT_Bus::Int	int
long long	xsd:long	corba:longlong	IT_Bus::Long	long
unsigned short	xsd:unsignedShort	corba:ushort	IT_Bus::UShort	int
unsigned long	xsd:unsignedInt	corba:ulong	IT_Bus::UInt	long
unsigned long long	xsd:unsignedLong	corba:ulonglong	IT_Bus::ULong	java.math.BigInteger
float	xsd:float	corba:float	IT_Bus::Float	float
double	xsd:double	corba:double	IT_Bus::Double	double
long double	<i>Not Supported</i>	<i>Not Supported</i>	<i>Not Supported</i>	<i>Not Supported</i>
octet	xsd:unsignedByte	corba:octet	IT_Bus::UByte	short
fixed	xsd:decimal	corba:fixed	IT_Bus::Decimal	java.math.BigDecimal

**Table 1:** *Primitive Type Mapping for CORBA Plug-in*

IDL Type	XML Schema Type	CORBA Binding Type	Artix C++ Type	Artix Java Type
Object	wsa:EndpointReferenceType	corba:object	WS_Addressings::EndpointReferenceType	
TimeBase::UtcT	xsd:dateTime <sup>a</sup>	corba:dateTime	IT_Bus::DateTime	java.util.Calendar

a. The mapping between `xsd:dateTime` and `TimeBase::UtcT` is only partial. For the restrictions see [“Unsupported time/date values” on page 116](#)

### Unsupported types

Artix does not support the CORBA `long double` type.

### Unsupported time/date values

The following `xsd:dateTime` values cannot be mapped to `TimeBase::UtcT`:

- Values with a local time zone. Local time is treated as a 0 UTC time zone offset.
- Values prior to 15 October 1582.
- Values greater than approximately 30,000 A.D.

The following `TimeBase::UtcT` values cannot be mapped to `xsd:dateTime`:

- Values with a non-zero `inacclo` or `inacchi`.
- Values with a time zone offset that is not divisible by 30 minutes.
- Values with time zone offsets greater than 14:30 or less than -14:30.
- Values with greater than millisecond accuracy.
- Values with years greater than 9999.

### String type

The IDL-to-WSDL mapping for strings is ambiguous, because the `string`, `wchar`, and `wstring` IDL types all map to the same type, `xsd:string`. This ambiguity can be resolved, however, because the generated WSDL records the original IDL type in the CORBA binding description (that is, within the scope of the `<wsdl:binding>` `</wsdl:binding>` tags). Hence, whenever an `xsd:string` is sent over a CORBA binding, it is automatically converted back to the original IDL type (`string`, `wchar`, or `wstring`).

**Fixed type**

The mapping of `fixed` is a special case. Although `fixed` maps directly to the `xsd:decimal` type, Artix must store additional mapping information in order to support round-trip conversion between WSDL and IDL. Therefore, Artix records the details of the IDL `fixed` mapping in a `corba:fixed` element (within the scope of the `corba:typeMapping` element). For example, the mapping of a `fixed<6, 2>` type might be recorded as follows:

```
<corba:typeMapping ... >
  <corba:fixed digits="6"
    scale="2"
    name="SampleTypes.Money"
    repositoryID="IDL:SampleTypes/Money:1.0"
    type="xsd:decimal"/>
</corba:typeMapping>
```

**Example**

The mapping of primitive types is handled in the CORBA binding section of the Artix contract. For example, consider an input message that has a part, `score`, that is described as an `xsd:int` as shown in [Example 13](#).

**Example 13:** *WSDL Operation Definition*

```
<message name="runsScored">
  <part name="score"/>
</message>
<portType ...>
  <operation name="getRuns">
    <input message="tns:runsScored" name="runsScored"/>
  </operation>
</portType>
```

It is described in the CORBA binding as shown in [Example 14](#).

**Example 14:** *Example CORBA Binding*

```
<binding ...>
  <operation name="getRuns">
    <corba:operation name="getRuns">
      <corba:param name="score" mode="in" idltype="corba:long"/>
    </corba:operation>
  <input/>
  <output/>
</operation>
</binding>
```

The IDL is shown in [Example 15](#).

**Example 15:** *getRuns IDL*

```
// IDL  
void getRuns(in score);
```

---

# IDL Complex Type Mapping

---

**Overview**

This section describes how the complex IDL data types are mapped to WSDL.

---

**In this section**

This section contains the following subsections:

<a href="#">IDL enum Type</a>	<a href="#">page 120</a>
<a href="#">IDL struct Type</a>	<a href="#">page 122</a>
<a href="#">IDL union Type</a>	<a href="#">page 124</a>
<a href="#">IDL sequence Types</a>	<a href="#">page 128</a>
<a href="#">IDL array Types</a>	<a href="#">page 130</a>
<a href="#">IDL exception Types</a>	<a href="#">page 132</a>
<a href="#">IDL typedef Expressions</a>	<a href="#">page 135</a>

## IDL enum Type

### Overview

An IDL enumeration maps to an XML string with enumeration facets. The mapped enumeration is a simple type derived by restriction from the `xsd:string` type.

### IDL example

Consider the following definition of an IDL enum type, `SampleTypes::Shape`:

```
// IDL
module SampleTypes {
    enum Shape { Square, Circle, Triangle };
    ...
};
```

### WSDL mapping

The IDL-to-WSDL compiler maps the `SampleTypes::Shape` enum to a WSDL restricted simple type, `SampleTypes.Shape`, as follows:

```
<xsd:simpleType name="SampleTypes.Shape">
  <xsd:restriction base="xsd:string">
    <xsd:enumeration value="Square"/>
    <xsd:enumeration value="Circle"/>
    <xsd:enumeration value="Triangle"/>
  </xsd:restriction>
</xsd:simpleType>
```

### CORBA type mapping

To support round-trip conversion between WSDL and IDL, Artix records the details of the enumeration type mapping in a `corba:enum` element (within the scope of the `corba:typeMapping` element), as follows:

```
<corba:typeMapping ... >
  <corba:enum name="SampleTypes.Shape"
    repositoryID="IDL:SampleTypes/Shape:1.0"
    type="xsd:SampleTypes.Shape">
    <corba:enumerator value="Square"/>
    <corba:enumerator value="Circle"/>
    <corba:enumerator value="Triangle"/>
  </corba:enum>
  ...
</corba:typeMapping>
```



**C++ mapping**

The WSDL-to-C++ compiler maps the `SampleTypes.Shape` type to a C++ class, `SampleTypes_Shape`, as follows:

```
// C++
class SampleTypes_Shape : public IT_Bus::AnySimpleType
{
    public:
        SampleTypes_Shape();
        SampleTypes_Shape(const IT_Bus::String & value);
        ...
        void set_value(const IT_Bus::String & value);
        const IT_Bus::String & get_value() const;
};
```

The value of the enumeration type can be accessed and modified using the `get_value()` and `set_value()` member functions.

**Java mapping**

The WSDL-to-Java compiler maps the `SampleTypes.Shape` type to a Java class, `SampleTypesShape`, as follows:

```
// Java
package com.iona.schemas.idltypes.sampletypes_idl;

public class SampleTypesShape
{
    ...
    public String getValue() { ... };

    public static
        com.iona.schemas.idltypes.sampletypes_idl.SampleTypesShape
        fromString(String value) { ... };
    ...
    public String toString() { ... }
}
```

To create a new `SampleTypesShape` object, call the `fromString()` method with the value argument equal to `Square`, `Circle`, or `Triangle`. Either the `getValue()` method or the `toString()` method can be used to access the value.

## IDL struct Type

### Overview

An IDL structure maps to an `xsd:sequence` type. Each field in the IDL structure maps to an element in the sequence.

### IDL example

Consider the following definition of an IDL struct type,

`SampleTypes::SampleStruct`:

```
// IDL
module SampleTypes {
    struct SampleStruct {
        string theString;
        long theLong;
    };
};
```

### WSDL mapping

The IDL-to-WSDL compiler maps the `SampleTypes::SampleStruct` struct to an XML schema sequence complex type, `SampleTypes.SampleStruct`, as follows:

```
<xsd:complexType name="SampleTypes.SampleStruct">
  <xsd:sequence>
    <xsd:element name="theString" type="xsd:string"/>
    <xsd:element name="theLong" type="xsd:int"/>
  </xsd:sequence>
</xsd:complexType>
```

### CORBA type mapping

To support round-trip conversion between WSDL and IDL, Artix records the details of the structure type mapping in a `corba:struct` element (within the scope of the `corba:typeMapping` element), as follows:

```
<corba:typeMapping ... >
  <corba:struct name="SampleTypes.SampleStruct"
    repositoryID="IDL:SampleTypes/SampleStruct:1.0"
    type="xsd1:SampleTypes.SampleStruct">
    <corba:member idltype="corba:string" name="theString"/>
    <corba:member idltype="corba:long" name="theLong"/>
  </corba:struct>
</corba:typeMapping>
```

**C++ mapping**

The WSDL-to-C++ compiler maps the `SampleTypes.SampleStruct` type to a C++ class, `SampleTypes_SampleStruct`, as follows:

```
// C++
class SampleTypes_SampleStruct : public
    IT_Bus::SequenceComplexType
{
public:
    SampleTypes_SampleStruct();
    SampleTypes_SampleStruct(const SampleTypes_SampleStruct&
        copy);
    ...
    const IT_Bus::String & gettheString() const;
    IT_Bus::String & gettheString();
    void settheString(const IT_Bus::String & val);

    const IT_Bus::Int & gettheLong() const;
    IT_Bus::Int & gettheLong();
    void settheLong(const IT_Bus::Int & val);
};
```

The members of the struct can be accessed and modified using the `getStructMember()` and `setStructMember()` pairs of functions.

**Java mapping**

The WSDL-to-Java compiler maps the `SampleTypes.SampleStruct` type to a Java class, `SampleTypesSampleStruct`, as follows:

```
// Java
package com.iona.schemas.idltypes.sampletypes_idl;

public class SampleTypesSampleStruct
{
    public String getTheString() { ... }
    public void setTheString(String val) { ... }

    public int getTheLong() { ... }
    public void setTheLong(int val) { ... }
    ...
    public String toString() { ... }
}
```

The members of the struct can be accessed and modified using the `getStructMember()` and `setStructMember()` pairs of methods.

---

## IDL union Type

---

### Overview

Unions are particularly difficult to describe using the XML schema framework. In the logical data type descriptions, the difficulty is how to describe the union without losing the relationship between the members of the union and the discriminator used to select the members. The easiest method is to describe a union using an `xsd:choice` and list the members in the specified order. The OMG's proposed method is to describe the union as an `xsd:sequence` containing one element for the discriminator and an `xsd:choice` to describe the members of the union. However, neither of these methods can accurately describe all the possible permutations of a CORBA union.

### IDL example

Consider the following definition of an IDL union type, `SampleTypes::Poly`:

```
// IDL
module SampleTypes {
    union Poly switch (short)
    {
        case 0:
            string StringCase0;
        case 1:
        case 2:
            float FloatCase1and2;
        default:
            long caseDef;
    };
};
```

### WSDL mapping

The IDL-to-WSDL compiler generates two alternative mappings for the IDL union type:

- Mapping to `xsd:choice`—the name of this type is `SampleTypes.Poly`. By default, Artix uses the `xsd:choice` type as the representation of the union throughout the contract.
- Mapping to `xsd:sequence`—the name of this type is obtained by prepending `_omg_` to the basic type name, giving `SampleTypes._omg_Poly`.

The two alternative mappings for the union type are, as follows:

```
<complexType name="SampleTypes.Poly">
  <choice>
    <element name="StringCase0" type="string"/>
    <element name="FloatCase1and2" type="float"/>
    <element name="caseDef" type="int"/>
  </choice>
</complexType>

<complexType name="SampleTypes._omg_Poly">
  <sequence>
    <element maxOccurs="1" minOccurs="1" name="discriminator"
      type="short"/>
    <choice maxOccurs="1" minOccurs="0">
      <element name="StringCase0" type="string"/>
      <element name="FloatCase1and2" type="float"/>
      <element name="caseDef" type="int"/>
    </choice>
  </sequence>
</complexType>
```

## CORBA type mapping

To support round-trip conversion between WSDL and IDL, Artix records the details of the union type mapping in a `corba:union` element (within the scope of the `corba:typeMapping` element), as follows:

```
<corba:typeMapping ... >
  <corba:union discriminator="corba:short"
    name="SampleTypes.Poly"
    repositoryID="IDL:SampleTypes/Poly:1.0"
    type="xsd:SampleTypes.Poly">
    <corba:unionbranch idltype="corba:string"
      name="StringCase0">
      <corba:case label="0"/>
    </corba:unionbranch>
    <corba:unionbranch idltype="corba:float"
      name="FloatCase1and2">
      <corba:case label="1"/>
      <corba:case label="2"/>
    </corba:unionbranch>
    <corba:unionbranch default="true"
      idltype="corba:long"
      name="caseDef"/>
  </corba:union>
</corba:typeMapping>
```

**C++ mapping**

The WSDL-to-C++ compiler maps the `SampleTypes.Poly` type to a C++ class, `SampleTypes_Poly`, as follows:

```
// C++
class SampleTypes_Poly : public IT_Bus::ChoiceComplexType
{
public:
    ...
    IT_Bus::String & getStringCase0();
    const IT_Bus::String & getStringCase0() const;
    void setStringCase0(const IT_Bus::String & val);

    IT_Bus::Float getFloatCaseland2();
    const IT_Bus::Float getFloatCaseland2() const;
    void setFloatCaseland2(const IT_Bus::Float val);

    IT_Bus::Int getcaseDef();
    const IT_Bus::Int getcaseDef() const;
    void setcaseDef(const IT_Bus::Int val);

    enum PolyDiscriminator
    {
        StringCase0_enum,
        FloatCaseland2_enum,
        caseDef_enum,
        SampleTypes_Poly_MAXLONG=-1
    } m_discriminator;

    PolyDiscriminator get_discriminator() const { ... }
    IT_Bus::UInt get_discriminator_as_uint() const { ... }
    ...
};
```

The value of the union can be modified and accessed using the `getUnionMember()` and `setUnionMember()` pairs of functions. The union discriminator can be accessed through the `get_discriminator()` and `get_discriminator_as_uint()` functions.

## Java mapping

The WSDL-to-Java compiler maps the `SampleTypes.Poly` type to a Java class, `SampleTypesPoly`, as follows:

```
// Java
package com.iona.schemas.idltypes.sampletypes_idl;

public class SampleTypesPoly
{
    ...
    public String getStringCase0() { ... }
    public void setStringCase0(String val) { ... }
    public boolean isSetStringCase0() { ... }

    public float getFloatCaseland2() { ... }
    public void setFloatCaseland2(float val) { ... }
    public boolean isSetFloatCaseland2() { ... }

    public int getCaseDef() { ... }
    public void setCaseDef(int val) { ... }
    public boolean isSetCaseDef() { ... }

    public javax.xml.namespace.QName _getQName() { ... }

    public String toString() { ... }
}
```

The contents of the union can be accessed and modified using the `getUnionMember()` and `setUnionMember()` pairs of methods. The `setUnionMember()` method implicitly sets the discriminator value.

## IDL sequence Types

### Overview

An IDL sequence maps to a sequence containing a single element that has `minOccurs` equal to zero and `maxOccurs` equal to the sequence's upper bound (`maxOccurs` equals `unbounded`, for an unbounded sequence).

### IDL example

Consider the following definition of an IDL unbounded sequence type, `SampleTypes::SeqOfStruct`:

```
// IDL
module SampleTypes {
    typedef sequence< SampleStruct > SeqOfStruct;
    ...
};
```

### WSDL mapping

The IDL-to-WSDL compiler maps the `SampleTypes::SeqOfStruct` sequence to a WSDL sequence type with occurrence constraints, `SampleTypes.SeqOfStruct`, as follows:

```
<xsd:complexType name="SampleTypes.SeqOfStruct">
  <xsd:sequence>
    <xsd:element name="item"
      type="xsd:SampleTypes.SampleStruct"
      minOccurs="0" maxOccurs="unbounded"/>
  </xsd:sequence>
</xsd:complexType>
```

### CORBA type mapping

To support round-trip conversion between WSDL and IDL, Artix records the details of the IDL sequence type mapping in a `corba:sequence` element (within the scope of the `corba:typeMapping` element), as follows:

```
<corba:typeMapping ... >
  <corba:sequence bound="0"
    elemtype="corbatm:SampleTypes.SampleStruct"
    name="SampleTypes.SeqOfStruct"
    repositoryID="IDL:SampleTypes/SeqOfStruct:1.0"
    type="xsd:SampleTypes.SeqOfStruct"/>
</corba:typeMapping>
```



**C++ mapping**

The WSDL-to-C++ compiler maps the `SampleTypes.SeqOfStruct` type to a C++ class, `SampleTypes_SeqOfStruct`, as follows:

```
class SampleTypes_SeqOfStruct : public
    IT_Bus::ArrayT<SampleTypes_SampleStruct,
        &SampleTypes_SeqOfStruct_item_qname, 0, -1>
{
public:
    ...
};
```

The `SampleTypes_SeqOfStruct` class is an Artix C++ array type (based on the `IT_Vector` template). Hence, the array class has an API similar to the `std::vector` type from the C++ Standard Template Library.

**Note:** IDL bounded sequences map in a similar way to normal IDL sequences, except that the `IT_Bus::ArrayT` base class uses the bounds specified in the IDL.

**Java mapping**

The WSDL-to-Java compiler maps the `SampleTypes.SeqOfStruct` type to a Java class, `SampleTypesSampleStruct`, as follows:

```
// Java
package com.iona.schemas.idltypes.sampletypes_idl;

public class SampleTypesSeqOfStruct
{
    ...
    public SampleTypesSampleStruct [] getItem() { ... }
    public void setItem(SampleTypesSampleStruct [] val) { ... }

    public javax.xml.namespace.QName _getQName() { ... }

    public String toString() { ... }
}
```

The `SampleTypesSampleStruct` type behaves like an array holder type. The `getItem()` and `setItem()` methods enable you to retrieve and set an array of `SampleTypeSampleStruct` items.

## IDL array Types

### Overview

An IDL array maps to a sequence containing a single element that sets both `minOccurs` and `maxOccurs` equal to the array bound.

### IDL example

Consider the following definition of an IDL union type, `SampleTypes::ArrOfStruct`:

```
// IDL
module SampleTypes {
    typedef SampleStruct ArrOfStruct [10];
    ...
};
```

### WSDL mapping

The IDL-to-WSDL compiler maps the `SampleTypes::ArrOfStruct` array to a WSDL sequence type with occurrence constraints, `SampleTypes.ArrOfStruct`, as follows:

```
<xsd:complexType name="SampleTypes.ArrOfStruct">
  <xsd:sequence>
    <xsd:element name="item"
      type="xsd:SampleTypes.SampleStruct"
      minOccurs="10" maxOccurs="10"/>
  </xsd:sequence>
</xsd:complexType>
```

### CORBA type mapping

To support round-trip conversion between WSDL and IDL, Artix records the details of the IDL array type mapping in a `corba:array` element (within the scope of the `corba:typeMapping` element), as follows:

```
<corba:typeMapping ... >
  <corba:array bound="10"
    elemtype="corbatm:SampleTypes.SampleStruct"
    name="SampleTypes.ArrOfStruct"
    repositoryID="IDL:SampleTypes/ArrOfStruct:1.0"
    type="xsd:SampleTypes.ArrOfStruct"/>
</corba:typeMapping>
```

**C++ mapping**

The WSDL-to-C++ compiler maps the `SampleTypes.ArrOfStruct` type to a C++ class, `SampleTypes_ArrOfStruct`, as follows:

```
class SampleTypes_ArrOfStruct : public
    IT_Bus::ArrayT<SampleTypes_SampleStruct,
    &SampleTypes_ArrOfStruct_item_qname, 10, 10>
{
    ...
};
```

The `SampleTypes_ArrOfStruct` class is an Artix C++ array type (based on the `IT_Vector` template). The array class has an API similar to the `std::vector` type from the C++ Standard Template Library, except that the size of the vector is restricted to the specified array length, 10.

**Java mapping**

The WSDL-to-Java compiler maps the `SampleTypes.ArrOfStruct` type to a Java class, `SampleTypesArrOfStruct`, as follows:

```
// Java
package com.iona.schemas.idltypes.sampletypes_idl;

public class SampleTypesArrOfStruct
{
    ...
    public SampleTypesSampleStruct[] getItem() { ... }
    public void setItem(SampleTypesSampleStruct[] val) { ... }

    public javax.xml.namespace.QName _getQName() { ... }

    public String toString() { ... }
}
```

The `SampleTypesArrOfStruct` type behaves like an array holder type. The `getItem()` and `setItem()` methods enable you to retrieve and set an array of `SampleTypeSampleStruct` items.

---

## IDL exception Types

---

### Overview

An IDL exception type maps to an `xsd:sequence` type and to an exception message. Each field in the IDL exception maps to an element in the `xsd:sequence`.

---

### IDL example

Consider the following definition of an IDL exception type, `SampleTypes::GenericException`:

```
// IDL
module SampleTypes {
    exception GenericExc {
        string reason;
    };
    ...
};
```

---

### WSDL mapping

The IDL-to-WSDL compiler maps the `SampleTypes::GenericExc` exception to a WSDL sequence type, `SampleTypes.GenericExc`, and to a WSDL fault message, `_exception.SampleTypes.GenericExc`, as follows:

```
<xsd:complexType name="SampleTypes.GenericExc">
  <xsd:sequence>
    <xsd:element name="reason" type="xsd:string"/>
  </xsd:sequence>
</xsd:complexType>
...
<xsd:element name="SampleTypes.GenericExc"
  type="xsd1:SampleTypes.GenericExc"/>
...
<message name="SampleTypes.GenericExc">
  <part element="xsd1:SampleTypes.GenericExc"
    name="exception"/>
</message>
```

**CORBA type mapping**

To support round-trip conversion between WSDL and IDL, Artix records the details of the IDL exception type mapping in a `corba:exception` element (within the scope of the `corba:typeMapping` element), as follows:

```
<corba:typeMapping ... >
  <corba:exception name="SampleTypes.GenericExc"
    repositoryID="IDL:SampleTypes/GenericExc:1.0"
    type="xsd:SampleTypes.GenericExc">
    <corba:member idltype="corba:string" name="reason"/>
  </corba:exception>
</corba:typeMapping>
```

**C++ mapping**

The WSDL-to-C++ compiler maps the `SampleTypes.GenericExc` type and `SampleTypes.GenericExc` message type to the C++ classes, `SampleTypes_GenericExc` and `SampleTypes_GenericExcException`, as follows:

```
// C++
class SampleTypes_GenericExc : public
  IT_Bus::SequenceComplexType
{
public:
  SampleTypes_GenericExc();
  ...
  const IT_Bus::String & getreason() const;
  IT_Bus::String & getreason();
  void setreason(const IT_Bus::String & val);
};
...
class SampleTypes_GenericExcException
  : public IT_Bus::UserFaultException,
  public IT_Bus::Rethrowable<SampleTypes_GenericExcException>
{
public:
  SampleTypes_GenericExcException();
  ...
  const SampleTypes_GenericExc & getexception() const;
  SampleTypes_GenericExc & getexception();
  void setexception(const SampleTypes_GenericExc & val);
  ...
};
```

**Java mapping**

The WSDL-to-Java compiler maps the `SampleTypes.GenericExc` message type to a Java class, `SampleTypesGenericExc_Exception`, as follows:

```
// Java
package com.iona.schemas.idltypes.sampletypes_idl;

public class SampleTypesGenericExc_Exception extends Exception
{
    public SampleTypesGenericExc_Exception(String reason) { ... }
    public SampleTypesGenericExc_Exception() { ... }

    public String getReason() { ... }
    public void setReason(String val) { ... }

    public javax.xml.namespace.QName _getQName() { ... }
    public String toString() { ... }
}
```

The exception members can be accessed and modified using the `getExceptionMember()` and `setExceptionMember()` pairs of methods.

---

## IDL typedef Expressions

---

### Overview

If a type is aliased in IDL, using a `typedef` expression, Artix simply replaces the type alias with the original type when mapping to WSDL.

**Note:** The typedef that defines an IDL sequence or an IDL array is treated as a special case, with a specific C++ class or Java class being generated to represent the sequence or array type.

### IDL example

Consider the following IDL typedef that defines an alias of a `float`, `SampleTypes::FloatAlias`, and an alias of a `struct`, `SampleTypes::SampleStruct`:

```
// IDL
module SampleTypes {
    typedef float FloatAlias;
    typedef SampleStruct SampleStructAlias;
    ...
};
```

### CORBA type mapping

To support round-trip conversion between WSDL and IDL, Artix records the details of each IDL alias mapping in a `corba:alias` element (within the scope of the `corba:typeMapping` element), as follows:

```
<corba:typeMapping ... >
  <corba:alias basetype="corba:float"
    name="SampleTypes.FloatAlias"
    repositoryID="IDL:SampleTypes/FloatAlias:1.0"
    type="xsd:float"/>
  <corba:alias basetype="corbatm:SampleTypes.SampleStruct"
    name="SampleTypes.SampleStructAlias"
    repositoryID="IDL:SampleTypes/SampleStructAlias:1.0"
    type="xsd:SampleTypes.SampleStruct"/>
</corba:typeMapping>
```

### WSDL mapping

The IDL-to-WSDL compiler maps the `SampleTypes::FloatAlias` type alias directly to the type, `xsd:float` and the `SampleTypes::SampleStructAlias` type alias directly to the type, `SampleTypes.SampleStruct`.

---

# IDL Module and Interface Mapping

---

## Overview

This section describes the Artix C++ mapping for the following IDL constructs:

- [Module mapping](#).
- [Interface mapping](#).
- [Object reference mapping](#).
- [Operation mapping](#).
- [Attribute mapping](#).

---

## Module mapping

An IDL identifier appearing within the scope of an IDL module, *ModuleName::Identifier*, maps to a C++ identifier of the form *ModuleName\_Identifier*. That is, the IDL scoping operator, `::`, maps to an underscore, `_`, in C++.

Although IDL modules do *not* map to namespaces under the Artix C++ mapping, it is possible nevertheless to put generated C++ code into a namespace using the `-n` switch to the WSDL-to-C++ compiler.

For example, if you pass a namespace, `TEST`, to the WSDL-to-C++ `-n` switch, the *ModuleName::Identifier* IDL identifier would map to `TEST::ModuleName_Identifier`.

---

## Interface mapping

An IDL interface, *InterfaceName*, maps to a C++ class of the same name, *InterfaceName*. If the interface is defined in the scope of a module, that is *ModuleName::InterfaceName*, the interface maps to the *ModuleName\_InterfaceName* C++ class.

If an IDL data type, *TypeName*, is defined within the scope of an IDL interface, that is *ModuleName::InterfaceName::TypeName*, the type maps to the *ModuleName\_InterfaceName\_TypeName* C++ class.



**Object reference mapping**

When an IDL interface is used as an operation parameter or return type, it is mapped to the `WS_Addressings::EndpointReferenceType` C++ type.

For example, consider an operation, `get_foo()`, that returns a reference to a `Foo` interface as follows:

```
// IDL
interface Foo {};

interface Bar {
    Foo get_foo();
};
```

The `get_foo()` IDL operation then maps to the following C++ function:

```
// C++
void get_foo(
    WS_Addressings::EndpointReferenceType & var_return
) IT_THROW_DECL(IT_Bus::Exception);
```

Note that this mapping is qualitatively different from the OMG IDL-to-C++ mapping. In the Artix mapping, the `get_foo()` operation does not return a pointer to a `Foo` proxy object. Instead, you must construct the `Foo` proxy object in a separate step, by passing the

`WS_Addressings::EndpointReferenceType` object into the `FooClient` constructor.

**Nil object reference**

A CORBA nil object reference maps to an empty endpoint reference. Conventionally, the address of an empty endpoint reference is represented by the following URI:

<http://www.w3.org/2005/08/addressing/none>

**Operation mapping**

[Example 16](#) shows two IDL operations defined within the `SampleTypes::Foo` interface. The first operation is a regular IDL operation, `test_op()`, and the second operation is a oneway operation, `test_oneway()`.

**Example 16:** *Example IDL Operations*

```
// IDL
module SampleTypes {
    ...
    interface Foo {
        ...
        SampleStruct test_op(
            in SampleStruct in_struct,
            inout SampleStruct inout_struct,
            out SampleStruct out_struct
        ) raises (GenericExc);

        oneway void test_oneway(in string in_str);
    };
};
```

The operations from the preceding IDL, [Example 16 on page 138](#), map to C++ as shown in [Example 17](#),

**Example 17:** *Mapping IDL Operations to C++*

```
// C++
class SampleTypes_Foo
{
    public:
        ...
1     virtual void test_op(
            const TEST::SampleTypes_SampleStruct & in_struct,
            TEST::SampleTypes_SampleStruct & inout_struct,
            TEST::SampleTypes_SampleStruct & var_return,
            TEST::SampleTypes_SampleStruct & out_struct
        ) IT_THROW_DECL((IT_Bus::Exception)) = 0;
2     virtual void test_oneway(
            const IT_Bus::String & in_str
        ) IT_THROW_DECL((IT_Bus::Exception)) = 0;
};
```

The preceding C++ operation signatures can be explained as follows:

1. The C++ mapping of an IDL operation always has the return type `void`. If a return value is defined in IDL, it is mapped as an out parameter, `var_return`.

The order of parameters in the C++ function signature, `test_op()`, is determined as follows:

- ◆ First, the in and inout parameters appear in the same order as in IDL, ignoring the out parameters.
  - ◆ Next, the return value appears as the parameter, `var_return` (with the same semantics as an out parameter).
  - ◆ Finally, the out parameters appear in the same order as in IDL, ignoring the in and inout parameters.
2. The C++ mapping of an IDL oneway operation is straightforward, because a oneway operation can have only in parameters and a `void` return type.

## Attribute mapping

[Example 18](#) shows two IDL attributes defined within the `SampleTypes::Foo` interface. The first attribute is readable and writable, `str_attr`, and the second attribute is readonly, `struct_attr`.

### Example 18: Example IDL Attributes

```
// IDL
module SampleTypes {
    ...
    interface Foo {
        ...
        attribute string          str_attr;
        readonly attribute SampleStruct struct_attr;
    };
};
```

The attributes from the preceding IDL, [Example 18 on page 139](#), map to C++ as shown in [Example 19](#),

**Example 19:** *Mapping IDL Attributes to C++*

```
// C++
class SampleTypes_Foo
{
public:
...
1 virtual void _get_str_attr(
    IT_Bus::String & var_return
) IT_THROW_DECL((IT_Bus::Exception)) = 0;

virtual void _set_str_attr(
    const IT_Bus::String & _arg
) IT_THROW_DECL((IT_Bus::Exception)) = 0;
2 virtual void _get_struct_attr(
    TEST::SampleTypes_SampleStruct & var_return
) IT_THROW_DECL((IT_Bus::Exception)) = 0;
};
```

The preceding C++ attribute signatures can be explained as follows:

1. A normal IDL attribute, *AttributeName*, maps to a pair of accessor and modifier functions in C++, `_get_AttributeName()`, `_set_AttributeName()`.
2. An IDL readonly attribute, *AttributeName*, maps to a single accessor function in C++, `_get_AttributeName()`.

# Artix WSDL-to-IDL Mapping

*This chapter describes how the Artix WSDL-to-IDL compiler maps WSDL types to OMG IDL types.*

---

**In this chapter**

This chapter discusses the following topics:

<a href="#">Simple Types</a>	<a href="#">page 142</a>
<a href="#">Complex Types</a>	<a href="#">page 157</a>
<a href="#">Wildcarding Types</a>	<a href="#">page 173</a>
<a href="#">Occurrence Constraints</a>	<a href="#">page 174</a>
<a href="#">Nillable Types</a>	<a href="#">page 176</a>
<a href="#">Recursive Types</a>	<a href="#">page 179</a>
<a href="#">Endpoint References</a>	<a href="#">page 182</a>
<a href="#">Mapping to IDL Modules</a>	<a href="#">page 195</a>

---

# Simple Types

---

**Overview**

This section describes the mapping of simple WSDL types to IDL.

---

**In this section**

This section contains the following subsections:

<a href="#">Atomic Types</a>	<a href="#">page 143</a>
<a href="#">String Type</a>	<a href="#">page 146</a>
<a href="#">Date and Time Types</a>	<a href="#">page 149</a>
<a href="#">Duration Type</a>	<a href="#">page 151</a>
<a href="#">Deriving Simple Types by Restriction</a>	<a href="#">page 152</a>
<a href="#">List Type</a>	<a href="#">page 154</a>
<a href="#">Unsupported Simple Types</a>	<a href="#">page 156</a>

## Atomic Types

### soapenc atomic types

Artix maps the `soapenc:string` type to the `string` IDL type (where the `soapenc` namespace prefix is identified with the `http://schemas.xmlsoap.org/soap/encoding/` namespace).

### Table of XSD atomic types

[Table 2](#) shows how the XSD schema atomic types map to IDL.

**Table 2:** *XSD Schema Simple Types Mapping to IDL*

XSD Schema Type	IDL Type
<code>xsd:boolean</code>	<code>boolean</code>
<code>xsd:byte</code>	<code>char</code>
<code>xsd:unsignedByte</code>	<code>octet</code>
<code>xsd:short</code>	<code>short</code>
<code>xsd:unsignedShort</code>	<code>unsigned short</code>
<code>xsd:int</code>	<code>long</code>
<code>xsd:unsignedInt</code>	<code>unsigned long</code>
<code>xsd:long</code>	<code>long long</code>
<code>xsd:unsignedLong</code>	<code>unsigned long long</code>
<code>xsd:float</code>	<code>float</code>
<code>xsd:double</code>	<code>double</code>
<code>xsd:string</code>	<code>string</code>
<code>xsd:normalizedString</code>	<code>string</code>
<code>xsd:token</code>	<code>string</code>
<code>xsd:language</code>	<code>string</code>
<code>xsd:NMTOKEN</code>	<code>string</code>

**Table 2:** XSD Schema Simple Types Mapping to IDL

XSD Schema Type	IDL Type
xsd:NMTOKENS	<i>Not supported</i>
xsd:Name	string
xsd:NCName	string
xsd:ID	string
xsd:QName	string
xsd:dateTime	TimeBase::UtcT
xsd:date	string
xsd:time	string
xsd:gDay	string
xsd:gMonth	string
xsd:gMonthDay	string
xsd:gYear	string
xsd:gYearMonth	string
xsd:duration	string
xsd:decimal	<i>Typedef of fixed&lt;31,6&gt;</i>
xsd:integer	long long
xsd:positiveInteger	unsigned long long
xsd:negativeInteger	long long
xsd:nonPositiveInteger	long long
xsd:nonNegativeInteger	unsigned long long
xsd:base64Binary	base64BinarySeq <i>(typedef of sequence&lt;octet&gt;)</i>



**Table 2:** XSD Schema Simple Types Mapping to IDL

XSD Schema Type	IDL Type
xsd:hexBinary	hexBinarySeq <i>(typedef of sequence&lt;octet&gt;)</i>
soapenc:base64	base64Seq <i>(typedef of sequence&lt;octet&gt;)</i>
xsd:ID	<i>Not supported.</i>

---

## String Type

---

### Overview

Artix can map strings both from the `soapenc` schema and from the XSD schema, as follows:

- [soapenc string type](#).
  - [XSD string type](#).
- 

### soapenc string type

Artix maps the `soapenc:string` type to the `string` IDL type (where the `soapenc` namespace prefix is identified with the `http://schemas.xmlsoap.org/soap/encoding/` namespace).

---

### XSD string type

By default, `xsd:string` maps to the ordinary IDL `string` type.

If you are planning to use international strings, however, you might want `xsd:string` to map to the IDL wide string type, `wstring`, instead. The `wsdltocorba` utility does not provide an option to change the default mapping, but you can easily alter the mapping by manually editing the contents of the CORBA `<binding>` tag in the WSDL.

---

### Default CORBA binding

Consider, for example, how to add a CORBA binding to the `Greeter` port type (see the `hello_world.wsdl` file located in *ArtixInstallDir/artix/Version/demos/basic/hello\_world\_soap\_http/etc*). You can add a CORBA binding by entering the following command:

```
> wsdltocorba -corba -i Greeter hello_world.wsdl
```

The WSDL output from this command, `hello_world-corba.wsdl`, includes a new CORBA binding, `GreeterCORBABinding`, as shown in [Example 20](#). The contents of this `binding` element essentially determine the WSDL-to-CORBA mapping for the port type. Some parameters and return types in the binding are declared to have an `idlname` attribute of `corba:string`, which means they map to the IDL `string` type.

**Example 20:** *Default CORBA Binding Generated by `wsdltocorba`*

```
<definitions ... >
  ...
  <binding name="GreeterCORBABinding" type="tns:Greeter">
```

**Example 20:** *Default CORBA Binding Generated by wsdltoCORBA*

```

<corba:binding repositoryID="IDL:Greeter:1.0"/>
<operation name="sayHi">
  <corba:operation name="sayHi">
    <corba:return idltype="corba:string" name="theResponse"/>
  </corba:operation>
  <input name="sayHiRequest"/>
  <output name="sayHiResponse"/>
</operation>
<operation name="greetMe">
  <corba:operation name="greetMe">
    <corba:param idltype="corba:string" mode="in" name="me"/>
    <corba:return idltype="corba:string" name="theResponse"/>
  </corba:operation>
  <input name="greetMeRequest"/>
  <output name="greetMeResponse"/>
</operation>
</binding>
</definitions>

```

**Manually modified CORBA binding**

To alter the WSDL-to-IDL string mapping, replace some or all of the instances of `corba:string` by `corba:wstring`. [Example 21](#) shows the result of replacing all instances of `corba:string` by `corba:wstring`.

**Example 21:** *Manually Modified CORBA Binding*

```

<definitions ... >
  ...
  <binding name="GreeterCORBABinding" type="tns:Greeter">
    <corba:binding repositoryID="IDL:Greeter:1.0"/>
    <operation name="sayHi">
      <corba:operation name="sayHi">
        <corba:return idltype="corba:wstring" name="theResponse"/>
      </corba:operation>
      <input name="sayHiRequest"/>
      <output name="sayHiResponse"/>
    </operation>
    <operation name="greetMe">
      <corba:operation name="greetMe">
        <corba:param idltype="corba:wstring" mode="in" name="me"/>
        <corba:return idltype="corba:wstring" name="theResponse"/>
      </corba:operation>
      <input name="greetMeRequest"/>
      <output name="greetMeResponse"/>
    </operation>
  </binding>
</definitions>

```

**Example 21:** *Manually Modified CORBA Binding*

```
</operation>
</binding>
</definitions>
```

**Generated IDL**

[Example 22](#) shows the IDL that would be generated from the modified CORBA binding in [Example 21 on page 147](#).

**Example 22:** *IDL Generated from the Modified CORBA Binding*

```
// IDL

interface Greeter {
    wstring sayHi();
    wstring greetMe(in wstring me);
};
```

To generate this IDL interface, you would enter the following command:

```
> wsdltoCorba -idl -b GreeterCORBABinding hello_world-corba.wsdl
```

---

## Date and Time Types

---

### Overview

The WSDL-to-IDL compiler maps the `xsd:dateTime` type to the `TimeBase::UtcT` IDL type.

**Note:** The mapping is subject to certain restrictions, as detailed below.

---

### TimeBase::UtcT type

The `TimeBase::UtcT` type, which holds a UTC time value, is defined in the OMG's *CORBA Time Service* specification. [Example 23](#) shows the definition of `UtcT` in the `TimeBase` module.

#### **Example 23:** *Definition of the TimeBase IDL Module*

```
// IDL
module TimeBase
{
    typedef unsigned long long TimeT;
    typedef TimeT          InaccuracyT;
    typedef short          TdfT;

    struct UtcT
    {
        TimeT          time;
        unsigned long  inacclo;
        unsigned short inacchi;
        TdfT           tdf;
    };

    struct IntervalT
    {
        TimeT lower_bound;
        TimeT upper_bound;
    };
};
```

---

### Unsupported time/date values

The following `xsd:dateTime` values cannot be mapped to `TimeBase::UtcT`:

- Values with a local time zone. Local time is treated as a 0 UTC time zone offset.
- Values prior to 15 October 1582.
- Values greater than approximately 30,000 A.D.

The following `TimeBase::UtcT` values cannot be mapped to `xsd:dateTime`:

- Values with a non-zero `inacclo` or `inacchi`.
- Values with a time zone offset that is not divisible by 30 minutes.
- Values with time zone offsets greater than 14:30 or less than -14:30.
- Values with greater than millisecond accuracy.
- Values with years greater than 9999.

---

## Duration Type

---

### Overview

The WSDL-to-IDL compiler maps the `xsd:duration` type to the `string` IDL type.

A *duration* represents an interval of time measured in years, months, days, hours, minutes, and seconds. This type is needed for representing the sort of time intervals that commonly appear in business and legal documents.

---

### Lexical representation

The lexical representation of a positive time duration is as follows:

```
P<years>Y<months>M<days>DT<hours>H<minutes>M<seconds>S
```

Where `<years>`, `<months>`, `<days>`, `<hours>`, and `<minutes>` are non-negative integers and `<seconds>` is a non-negative decimal. The `<seconds>` field can have an arbitrary number of decimal digits, but Artix considers the digits only up to millisecond precision. The `P`, `Y`, `M`, `D`, `T`, `H`, `M`, and `S` separator characters must all be upper case. The `T` is the date/time separator. To represent a negative time duration, you can add a minus sign, `-`, in front of the `P` character.

Here are some examples:

```
P2Y6M10DT12H20M15S  
-P1Y0M0DT0H0M0.001S
```

You can abbreviate the duration string by omitting any fields that are equal to zero. You must omit the date/time separator, `T`, if and only if all of the time fields are absent. For example, `P1Y` would represent one year.

---

## Deriving Simple Types by Restriction

---

### Overview

Most derived simple types are mapped as if they had been declared to be the base type. For example, XSD types derived from `xsd:string` are treated as if they were declared as `xsd:string` and are therefore mapped to the IDL `string` type.

Exceptionally, derived simple types declared using the `<enumeration>` facet are treated as a special case: enumerated simple types are mapped to an IDL `enum` type.

---

### Unchecked facets

The following facets can be used, but are not checked at runtime:

- `length`
- `minLength`
- `maxLength`
- `pattern`
- `enumeration`
- `whiteSpace`
- `maxInclusive`
- `maxExclusive`
- `minInclusive`
- `minExclusive`
- `totalDigits`
- `fractionDigits`

---

### Checked facets

The following facets are supported and checked at runtime:

- `enumeration`



**Example with a maxLength facet**

The following example shows how you can use the `<maxLength>` facet to define a string whose length is limited to 100 characters:

```
<xsd:simpleType name="String100">
  <xsd:restriction base="xsd:string">
    <xsd:maxLength value="100"/>
  </xsd:restriction>
</xsd:simpleType>
```

The WSDL-to-IDL mapping maps this `String100` type to the `string` type.

**Example with enumeration facets**

The following example shows how to define an enumerated type, `ColorEnum`, using the `<enumeration>` facet:

```
<xsd:simpleType name="ColorEnum">
  <xsd:restriction base="xsd:string">
    <xsd:enumeration value="RED"/>
    <xsd:enumeration value="GREEN"/>
    <xsd:enumeration value="BLUE"/>
  </xsd:restriction>
</xsd:simpleType>
```

The WSDL-to-IDL mapping maps this `ColorEnum` type to the following IDL `enum` type.

```
// IDL
enum ColorEnum {
    RED,
    GREEN,
    BLUE
};
```

---

# List Type

---

## Overview

An `xsd:list` type maps to an IDL sequence type, `sequence<MappedElementType>`, where *MappedElementType* is the IDL type representing the list elements.

There are two styles of list declaration, both of which are supported in Artix:

- [Lists defined using itemType](#).
- [Lists defined by derivation](#).

---

## Lists defined using itemType

Where the list element type is a schema atomic type, you can define the list type using the `itemType` attribute. For example, a list of strings can be defined as follows:

```
<xsd:simpleType name="StringList">
  <xsd:list itemType="xsd:string"/>
</xsd:simpleType>
```

This maps to the following IDL type:

```
// IDL
typedef sequence<string> StringList;
```

---

## Lists defined by derivation

Where the list element type is derived from a schema atomic type (by the application of various restricting facets), you can define the list type using a `restriction` element. For example, you can define a list of restricted integers as follows:

```
<xsd:simpleType name="IntList">
  <xsd:list>
    <xsd:simpleType>
      <xsd:restriction base="xsd:int">
        <xsd:maxInclusive value="1000"/>
      </xsd:restriction>
    </xsd:simpleType>
  </xsd:list>
</xsd:simpleType>
```

This maps to the following IDL type:

```
// IDL  
typedef sequence<long> IntList;
```

---

## Unsupported Simple Types

---

### Overview

This subsection lists the XSD simple types that are not supported by the `wsdltocorba` mapping utility.

---

### Unsupported types

The following XSD simple types are not supported by the WSDL-to-IDL mapping:

```
xsd:ENTITY  
xsd:ENTITIES  
xsd:IDREF  
xsd:IDREFS  
xsd:NMOKENS  
xsd:NOTATION  
xsd:union
```

---

# Complex Types

**Overview**

---

This section describes the mapping of complex WSDL types to IDL.

---

**In this section**

This section contains the following subsections:

<a href="#">Sequence Complex Types</a>	<a href="#">page 158</a>
<a href="#">Choice Complex Types</a>	<a href="#">page 159</a>
<a href="#">All Complex Types</a>	<a href="#">page 160</a>
<a href="#">Attributes</a>	<a href="#">page 161</a>
<a href="#">Nesting Complex Types</a>	<a href="#">page 163</a>
<a href="#">Deriving a Complex Type from a Simple Type</a>	<a href="#">page 165</a>
<a href="#">Deriving a Complex Type from a Complex Type</a>	<a href="#">page 167</a>
<a href="#">Arrays</a>	<a href="#">page 170</a>

---

## Sequence Complex Types

---

### Overview

The XSD sequence complex type maps to an IDL `struct` type, where each element of the original sequence maps to a member of the IDL `struct`.

---

### Occurrence constraints

The WSDL-to-IDL mapping does *not* support occurrence constraints on the `sequence` element. If `minOccurs` or `maxOccurs` attribute settings appear in the `sequence` element, they are ignored by the WSDL-to-IDL compiler.

On the other hand, elements appearing *within* the `sequence` element can define occurrence constraints—see [“Arrays” on page 170](#).

---

### WSDL example

[Example 24](#) shows an XSD sequence type with three simple elements.

#### **Example 24:** *Definition of a Sequence Complex Type in WSDL*

```
<xsd:complexType name="SimpleStruct">
  <xsd:sequence>
    <xsd:element name="varFloat" type="xsd:float"/>
    <xsd:element name="varInt" type="xsd:int"/>
    <xsd:element name="varString" type="xsd:string"/>
  </xsd:sequence>
</xsd:complexType>
```

---

### IDL mapping

[Example 25](#) shows the result of mapping the `SimpleStruct` type (from the preceding [Example 24](#)) to IDL.

#### **Example 25:** *Mapping of SimpleStruct to IDL*

```
// IDL
struct SimpleStruct {
    float varFloat;
    long varInt;
    string varString;
};
```

---

## Choice Complex Types

---

### Overview

The XSD choice complex type maps to an IDL `union` type, where each element of the original choice maps to a member of the IDL `union`.

---

### Occurrence constraints

Artix does not support occurrence constraints on the `choice` element.

---

### WSDL example

[Example 26](#) shows an XSD choice type with three elements.

#### **Example 26:** *Definition of a Choice Complex Type in WSDL*

```
<xsd:complexType name="SimpleChoice">
  <xsd:choice>
    <xsd:element name="varFloat" type="xsd:float"/>
    <xsd:element name="varInt" type="xsd:int"/>
    <xsd:element name="varString" type="xsd:string"/>
  </xsd:choice>
</xsd:complexType>
```

---

### IDL mapping

[Example 27](#) shows the result of mapping the `SimpleChoice` type (from the preceding [Example 26](#)) to IDL.

#### **Example 27:** *Mapping of SimpleChoice to IDL*

```
// IDL
union SimpleChoice switch (long) {
  case 0:
    float varFloat;
  case 1:
    long varInt;
  case 2:
    string varString;
};
```

---

## All Complex Types

---

**Overview** The XSD all complex type maps to an IDL `struct` type, where each element of the original all maps to a member of the IDL `struct`.

---

**Occurrence constraints** Artix does not support occurrence constraints on the `all` element.

---

**WSDL example** [Example 28](#) shows an XSD all type with three simple elements.

**Example 28:** *Definition of an All Complex Type in WSDL*

```
<xsd:complexType name="SimpleAll">
  <xsd:all>
    <xsd:element name="varFloat" type="xsd:float"/>
    <xsd:element name="varInt" type="xsd:int"/>
    <xsd:element name="varString" type="xsd:string"/>
  </xsd:all>
</xsd:complexType>
```

---

**IDL mapping** [Example 29](#) shows the result of mapping the `SimpleAll` type (from the preceding [Example 28](#)) to IDL.

**Example 29:** *Mapping of SimpleAll to IDL*

```
// IDL
struct SimpleAll {
  float varFloat;
  long varInt;
  string varString;
};
```



---

# Attributes

---

## Overview

Attributes of a sequence type or of an all type map to additional members of an IDL `struct`. The type representing an attribute in IDL is defined as a *nillable type* (see “[Nillable Types](#)” on page 176 for details). This makes it possible for attributes to be treated as optional.

Attributes can be declared within the scope of the `xsd:complexType` element. Hence, you can include attributes in the definitions of an all type, a sequence type, and a choice type.

**Note:** Attributes of a choice type are currently *not* supported by the WSDL-to-IDL mapping.

The declaration of an attribute in a complex type has the following syntax:

```
<xsd:complexType name="TypeName">
  <xsd:attribute name="AttrName" type="AttrType"
                use="[optional|required|prohibited]"/>
  ...
</xsd:complexType>
```

---

## Attribute use

The `use` attribute setting is ignored by the WSDL-to-IDL mapping.

Because attributes are declared as nillable types in IDL, the attributes are effectively `optional` by default. If the attribute `use` is defined as `required` or `prohibited`, however, it is up to the developer to enforce these conditions.

**WSDL example**

[Example 30](#) shows an XSD sequence type, which is declared to have two attributes, `varAttrString` and `varAttrIntOptional`.

**Example 30:** *Definition of a Complex Type with Attributes in WSDL*

```
<xsd:complexType name="SimpleStructWithAttributes">
  <xsd:sequence>
    <xsd:element name="varFloat" type="xsd:float"/>
    <xsd:element name="varInt" type="xsd:int"/>
    <xsd:element name="varString" type="xsd:string"/>
  </xsd:sequence>
  <xsd:attribute name="varAttrString" type="xsd:string"/>
  <xsd:attribute name="varAttrIntOptional" type="xsd:int"
    use="optional"/>
</xsd:complexType>
```

**IDL mapping**

[Example 31](#) shows the result of mapping the `SimpleStructWithAttributes` type (from the preceding [Example 30](#)) to IDL.

**Example 31:** *Mapping of SimpleStructWithAttributes to IDL*

```
// IDL
union string_nil switch(boolean) {
  case TRUE:
    string value;
};
union long_nil switch(boolean) {
  case TRUE:
    long value;
};

struct SimpleStructWithAttributes {
  string_nil varAttrString;
  long_nil varAttrIntOptional;
  float varFloat;
  long varInt;
  string varString;
};
```

---

## Nesting Complex Types

---

### Overview

It is possible to nest complex types within each other. When mapped to IDL, the nested complex types map to a nested hierarchy of structs, where each instance of a nested type is declared as a member of another struct.

### Avoiding anonymous types

In general, it is recommended that you name types that are nested inside other types, instead of using anonymous types. This results in simpler code when the types are mapped to IDL.

**Note:** The WSDL-to-IDL mapping has only limited supported for mapping anonymous type, which does not work in all cases.

### WSDL example

[Example 32](#) shows the definition of a nested sequence type, `NestedStruct`, which contains another sequence type, `SimpleStruct`, as an element.

#### Example 32: Definition of a Nested Type in WSDL

```
<xsd:complexType name="SimpleStruct">
  <xsd:sequence>
    <xsd:element name="varFloat" type="xsd:float"/>
    <xsd:element name="varInt" type="xsd:int"/>
    <xsd:element name="varString" type="xsd:string"/>
  </xsd:sequence>
</xsd:complexType>

<xsd:complexType name="NestedStruct">
  <xsd:sequence>
    <xsd:element name="varString" type="xsd:string"/>
    <xsd:element name="varInt" type="xsd:int"/>
    <xsd:element name="varFloat" type="xsd:float"/>
    <xsd:element name="varStruct" type="tns:SimpleStruct"/>
  </xsd:sequence>
</xsd:complexType>
```

**IDL mapping**

[Example 33](#) shows the result of mapping the `NestedStruct` type (from the preceding [Example 32](#)) to IDL.

**Example 33:** *Mapping of NestedStruct to IDL*

```
// IDL
struct SimpleStruct {
    float varFloat;
    long varInt;
    string varString;
};

struct NestedStruct {
    string varString;
    long varInt;
    float varFloat;
    SimpleStruct varStruct;
};
```

---

## Deriving a Complex Type from a Simple Type

---

### Overview

A complex type derived from a simple type maps to an IDL `struct` type with a member, `_simpleTypeValue`, to hold the value of the simple type. Any attributes defined by the derived type are represented as nillable members of the struct (see “Attributes” on page 161 for more details).

The following kinds of derivation are supported:

- [Derivation by restriction.](#)
- [Derivation by extension.](#)

### Derivation by restriction

[Example 34](#) shows an example of a complex type, `OrderNumber`, derived by restriction from the `xsd:decimal` simple type. The new type is restricted to have values less than 1,000,000.

**Example 34:** *Complex Type Derived by Restriction from a Simple Type*

```
<xsd:complexType name="OrderNumber">
  <xsd:simpleContent>
    <xsd:restriction base="xsd:decimal">
      <xsd:maxExclusive value="1000000"/>
    </xsd:restriction>
  </xsd:simpleContent>
</xsd:complexType>
```

### IDL mapping of restricted type

[Example 35](#) shows the result of mapping the `OrderNumber` type (from the preceding [Example 34](#)) to IDL. The `_simpleTypeValue` struct member represents the simple type value.

**Example 35:** *Mapping of OrderNumber to IDL*

```
// IDL
typedef fixed<31, 6> fixed_1;

struct OrderNumber {
    fixed_1 _simpleTypeValue;
};
```

**Derivation by extension**

[Example 36](#) shows an example of a complex type, `InternationalPrice`, derived by extension from the `xsd:decimal` simple type. The new type is extended to include a currency attribute.

**Example 36:** *Complex Type Derived by Extension from a Simple Type*

```
<xsd:complexType name="InternationalPrice">
  <xsd:simpleContent>
    <xsd:extension base="xsd:decimal">
      <xsd:attribute name="currency" type="xsd:string"/>
    </xsd:extension>
  </xsd:simpleContent>
</xsd:complexType>
```

**IDL mapping of extended type**

[Example 37](#) shows the result of mapping the `InternationalPrice` type (from the preceding [Example 36](#)) to IDL. In addition to the `_simpleTypeValue` member, representing the simple type, there is a `currency` member of `string_nil` type, representing the currency attribute.

**Example 37:** *Mapping of InternationalPrice to IDL*

```
// IDL
union string_nil switch(boolean) {
  case TRUE:
    string value;
};
typedef fixed<31, 6> fixed_1;

struct InternationalPrice {
  string_nil currency;
  fixed_1 _simpleTypeValue;
};
```

---

## Deriving a Complex Type from a Complex Type

---

### Overview

Artix supports derivation of a complex type from a complex type, for which the following kinds of derivation are possible:

- Derivation by restriction.
- Derivation by extension.

### Allowed inheritance relationships

Figure 18 shows the inheritance relationships allowed between complex types. All of these inheritance relationships are supported by the WSDL-to-IDL mapping, including cross-inheritance. For example, a sequence can derive from a choice, a choice from an all, an all from a choice, and so on.

**Figure 18:** *Allowed Inheritance Relationships for Complex Types*

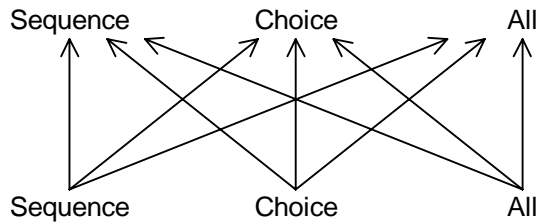

**IDL mapping**

Artix maps schema derived types to an IDL struct (irrespective of whether the schema derived type is a `sequence`, a `choice`, or an `all`). The generated IDL struct always contains the following two members:

- *The base member*—holds an instance of the base type, *BaseType*. The name of this member is *BaseType\_f*.
- *The extension member*—holds an instance of the extension type. The name of this member obeys the following naming convention (where *DerivedType* is the name of the derived type in XML):
  - ◆ `sequence` extension—the name is *DerivedTypeSequenceStruct\_f*.
  - ◆ `choice` extension—the name is *DerivedTypeChoiceType\_f*.
  - ◆ `all` extension—the name is *DerivedTypeAllStruct\_f*.

In addition, if the derived type defines attributes, they are mapped directly to members of the IDL struct.

**WSDL example**

[Example 38](#) shows the definition of a derived type that is obtained by extending a `sequence` type (base type) with a `choice` type (extension type).

**Example 38:** *XML Example of a Choice Type Derived from a Struct Type*

```
// Base type.
<xsd:complexType name="SimpleStruct">
  <xsd:sequence>
    <xsd:element name="varFloat" type="xsd:float"/>
    <xsd:element name="varInt" type="xsd:int"/>
    <xsd:element name="varString" type="xsd:string"/>
  </xsd:sequence>
</xsd:complexType>

// Derived type.
<xsd:complexType name="DerivedChoice_BaseStruct">
  <xsd:complexContent mixed="false">
    <xsd:extension base="s:SimpleStruct">
      <xsd:choice>
        <xsd:element name="varStringExt"
          type="xsd:string"/>
        <xsd:element name="varFloatExt" type="xsd:float"/>
      </xsd:choice>
      <xsd:attribute name="attrString" type="xsd:string"/>
    </xsd:extension>
  </xsd:complexContent>
</xsd:complexType>
```



**Example 38:** XML Example of a Choice Type Derived from a Struct Type

```
</xsd:complexType>
```

**Mapped example**

The preceding `DerivedChoice_BaseStruct` schema type maps to an IDL struct, `DerivedChoice_BaseStruct`, as shown in [Example 39](#).

**Example 39:** IDL Mapping of the `DerivedChoice_BaseStruct` Type

```
// IDL

// Base type.
struct SimpleStruct {
    float varFloat;
    long varInt;
    string varString;
};

// Extended part of derived type.
union DerivedChoice_BaseStructChoiceType switch(long) {
    case 0:
        string varStringExt;
    case 1:
        float varFloatExt;
};

// Derived type.
struct DerivedChoice_BaseStruct {
    string_nil attrString;

    SimpleStruct SimpleStruct_f;
    DerivedChoice_BaseStructChoiceType
        DerivedChoice_BaseStructChoiceType_f;
};
```

## Arrays

### Overview

An Artix array is a sequence complex type that satisfies the following special conditions:

- The sequence complex type schema defines a *single* element only.
- The element definition has a `maxOccurs` attribute with a value greater than 1.

**Note:** All elements implicitly have `minOccurs=1` and `maxOccurs=1`, unless specified otherwise.

Hence, an Artix array definition has the following general syntax:

```
<complexType name="ArrayName">
  <sequence>
    <element name="ElemName" type="ElemType"
      minOccurs="LowerBound" maxOccurs="UpperBound"/>
  </sequence>
</complexType>
```

The *ElemType* specifies the type of the array elements and the number of elements in the array can be anywhere in the range *LowerBound* to *UpperBound*.

### Mapping arrays to IDL

The way Artix maps arrays to IDL depend on the values of the `minOccurs` and `maxOccurs` attributes, as shown in [Table 3](#).

**Table 3:** Array to IDL Mapping for Various Occurrence Constraints

Occurrence Constraints	IDL Type
<code>minOccurs="N" maxOccurs="N"</code>	<code>ArrayName[N]</code>
<code>minOccurs="N" maxOccurs="M"</code> (with $N < M$ )	<code>sequence&lt;ElementType, M&gt;</code>
<code>maxOccurs="unbounded"</code>	<code>sequence&lt;ElementType&gt;</code>

## Fixed array

The following XSD schema shows the definition of an array, `FixedArray`, whose `minOccurs` and `maxOccurs` constraints are set to an identical, finite value.

```
<xsd:complexType name="FixedArray">
  <xsd:sequence>
    <xsd:element maxOccurs="3" minOccurs="3"
      name="item" type="xsd:int"/>
  </xsd:sequence>
</xsd:complexType>
```

The preceding `FixedArray` schema type maps to the following IDL array:

```
// IDL
typedef long FixedArray[3];
```

## Bounded array

The following XSD schema shows the definition of an array, `BoundedArray`, whose `minOccurs` and `maxOccurs` constraints are finite and unequal.

```
<xsd:complexType name="BoundedArray">
  <xsd:sequence>
    <xsd:element maxOccurs="3" minOccurs="1"
      name="item" type="xsd:float"/>
  </xsd:sequence>
</xsd:complexType>
```

The preceding `BoundedArray` schema type maps to the following IDL bounded sequence type:

```
// IDL
typedef sequence<float, 3> BoundedArray;
```

## Unbounded array

The following XSD schema shows the definition of an array, `UnboundedArray`, whose `maxOccurs` constraint is unbounded.

```
<xsd:complexType name="UnboundedArray">
  <xsd:sequence>
    <xsd:element maxOccurs="unbounded" minOccurs="0"
      name="item" type="xsd:string"/>
  </xsd:sequence>
</xsd:complexType>
```

The preceding `UnboundedArray` schema type maps to the following IDL unbounded sequence type:

```
// IDL
typedef sequence<string> UnboundedArray;
```

## Nested arrays

The following XSD schema shows the definition of a nested array, `NestedArray`, which is defined as an array whose elements are of `UnboundedArray` type.

```
<xsd:complexType name="NestedArray">
  <xsd:sequence>
    <xsd:element maxOccurs="unbounded" minOccurs="0"
      name="subarray" type="s:UnboundedArray"/>
  </xsd:sequence>
</xsd:complexType>
```

The preceding `NestedArray` schema type maps to the following IDL unbounded sequence type:

```
// IDL
typedef sequence<UnboundedArray> NestedArray;
```

# Wildcarding Types

## Overview

The XML schema wildcarding types enable you to define XML types with loosely defined characteristics. [Table 4](#) shows how the XSD schema wildcarding types map to IDL.

**Table 4:** XSD Schema Simple Types Mapping to IDL

XSD Schema Type	IDL Type
xsd:anyURI	string
xsd:anyType	any
xsd:any	Not supported

## xsd:anyType example

Consider an XSD sequence, `AnyStruct`, whose elements are declared to be of `xsd:anyType` type, as shown in [Example 40](#).

**Example 40:** AnyStruct Schema Type with `xsd:anyType` Members

```
<xsd:complexType name="AnyStruct">
  <xsd:sequence>
    <xsd:element name="varAny_1" type="xsd:anyType"/>
    <xsd:element name="varAny_2" type="xsd:anyType"/>
  </xsd:sequence>
</xsd:complexType>
```

The preceding `AnyStruct` schema type maps to the IDL struct type shown in [Example 41](#).

**Example 41:** Mapping of AnyStruct Type to IDL

```
struct AnyStruct {
  any varAny_1;
  any varAny_2;
};
```

---

# Occurrence Constraints

---

## Overview

Certain XML schema tags—for example, `<element>`, `<sequence>`, `<choice>` and `<any>`—can be declared to occur multiple times using *occurrence constraints*. The occurrence constraints are specified by assigning integer values (or the special value `unbounded`) to the `minOccurs` and `maxOccurs` attributes.

The WSDL-to-IDL mapping currently supports only *element occurrence constraints* (that is, `minOccurs` and `maxOccurs` attribute settings within the `<element>` tag).

---

## Element occurrence constraints

You define occurrence constraints on a schema element by setting the `minOccurs` and `maxOccurs` attributes for the element. Hence, the definition of an element with occurrence constraints in an XML schema element has the following form:

```
<element name="ElemName" type="ElemType" minOccurs="LowerBound"
maxOccurs="UpperBound"/>
```

**Note:** When a sequence schema contains a *single* element definition and this element defines occurrence constraints, it is treated as an array. See [“Arrays” on page 170](#).

---

## Limitations

In the current version of Artix, element occurrence constraints can be used only within the following complex types:

- all complex types,
- sequence complex types.

Element occurrence constraints are *not* supported within the scope of the following:

- choice complex types.
- 

## Mapping to IDL

Given an `<xsd:element name="ElemName" ... >` element with occurrence constraints, defined in an `<xsd:sequence>` or an `<xsd:any>` tag, Artix defines an `ElemNameArray` type in IDL to represent the multiply occurring element.

The *ElemNameArray* type is defined according to the rules in [Table 3 on page 170](#), which determine the mapped IDL type based on the values of the `minOccurs` and `maxOccurs` attributes.

### Example of element occurrence constraints

The following XSD schema shows the definition of an `<xsd:sequence>` type, `CompoundArray`, which has two multiply occurring member elements.

```
<xsd:complexType name="CompoundArray">
  <xsd:sequence>
    <xsd:element maxOccurs="unbounded" minOccurs="0"
      name="array1" type="xsd:string"/>
    <xsd:element maxOccurs="unbounded" minOccurs="0"
      name="array2" type="xsd:string"/>
  </xsd:sequence>
</xsd:complexType>
```

The preceding `CompoundArray` schema type maps to the following IDL struct, `CompoundArray`, which uses two generated array types, `array1Array` and `array2Array`, to represent the types of its member elements:

```
// IDL
typedef sequence<string> array1Array;
typedef sequence<string> array2Array;

struct CompoundArray {
  array1Array array1;
  array2Array array2;
};
```

---

# Nillable Types

## Overview

An element in an XML schema may be declared as nillable by setting the `nillable` attribute equal to `true`. This is useful in cases where you would like to have the option of transmitting no value for a type (for example, if you would like to define an operation with optional parameters).

## Nillable syntax

To declare an element as nillable, use the following syntax:

```
<element name="ElementName" type="ElementType" nillable="true"/>
```

The `nillable="true"` setting indicates that this is a nillable element. If the `nillable` attribute is missing, the default is value is `false`.

## Mapping to IDL

If a given element of *ElementType* type is defined with `nillable="true"` and *ElementType* maps to *MappedType* in IDL, Artix automatically generates a union IDL type, *MappedType\_nil*, as follows:

```
// IDL
union MappedType_nil switch(boolean) {
    case TRUE:
        MappedType value;
};
```

Artix uses this *MappedType\_nil* type to represent the type of the nillable element in IDL (for example, where it appears as the member of a struct and so on).

## Example

The following XSD schema shows the definition of an `<xsd:sequence>` type, `StructWithNillables`, which contains several nillable elements:

```
<xsd:complexType name="SimpleStruct">
  <xsd:sequence>
    <xsd:element name="varFloat" type="xsd:float"/>
    <xsd:element name="varInt" type="xsd:int"/>
    <xsd:element name="varString" type="xsd:string"/>
  </xsd:sequence>
  <xsd:attribute name="varAttrString" type="xsd:string"/>
</xsd:complexType>
```



```

<xsd:complexType name="StructWithNillables">
  <xsd:sequence>
    <xsd:element name="varFloat" nillable="true"
      type="xsd:float"/>
    <xsd:element name="varInt" nillable="true"
      type="xsd:int"/>
    <xsd:element name="varString" nillable="true"
      type="xsd:string"/>
    <xsd:element name="varStruct" nillable="true"
      type="s:SimpleStruct"/>
  </xsd:sequence>
</xsd:complexType>

```

The preceding `StructWithNillables` schema type maps to the IDL `struct`, `StructWithNillables`, which uses generated nillable types, `float_nil`, `long_nil`, `string_nil` and `SimpleStruct_nil`, to represent the types of its member elements:

```

// IDL
union float_nil switch(boolean) {
  case TRUE:
    float value;
};
union long_nil switch(boolean) {
  case TRUE:
    long value;
};
union string_nil switch(boolean) {
  case TRUE:
    string value;
};

struct SimpleStruct {
  string_nil varAttrString;
  float varFloat;
  long varInt;
  string varString;
};
union SimpleStruct_nil switch(boolean) {
  case TRUE:
    SimpleStruct value;
};

```

```
struct StructWithNullables {  
    float_nil varFloat;  
    long_nil varInt;  
    string_nil varString;  
    SimpleStruct_nil varStruct;  
};
```

---

# Recursive Types

---

## Overview

XML schema allows you to define *recursive* types and the WSDL-to-IDL compiler is able to map these types into OMG IDL. The following kinds of recursive type are considered here:

- *Self-recursive types*—a type that refers to itself within its own definition.
- *Mutually-recursive types*—for example, given two types, A and B, the definition of A refers to B and the definition of B refers to A.

More complex recursions are also supported—for example, where A refers to B refers to C refers to A (in shorthand,  $A \rightarrow B \rightarrow C \rightarrow A$ ). Overlapping recursions are also supported—for example,  $A \rightarrow C \rightarrow A$  and  $A \rightarrow B \rightarrow C \rightarrow A$  at the same time.

**Note:** Mutual recursion does not work, however, in cases where the recursive types are defined in separate IDL modules. See [“Circular references across modules” on page 197](#).

The IDL mapping of recursive types relies on the use of forward declarations of IDL structs.

**Note:** Forward declaration of structs is a relatively new feature of the OMG IDL syntax and might not be supported by all ORB products.

## Complex types that can use recursion

The following complex XML schema types can be defined with recursion:

- `xsd:sequence`,
- `xsd:union`,
- `xsd:all`.

**XML schema example of self-recursive type**

[Example 42](#) shows an example of a self-recursive sequence—that is, a sequence type, `RecurSeq`, that contains a reference to itself.

**Example 42:** *XML Example of a Self-Recursive Type*

```
<xsd:complexType name="RecurSeq">
  <xsd:sequence>
    <xsd:element name="value" type="xsd:long"/>
    <xsd:element name="RecurSeqs" type="s:RecurSeq"
      minOccurs="0" maxOccurs="unbounded"/>
  </xsd:sequence>
</xsd:complexType>
```

**Note:** In this example, it is important to set `minOccurs` equal to zero, otherwise the recursion could never terminate.

**IDL mapping of self-recursive type**

[Example 43](#) shows how the self-recursive type, `RecurSeq`, (from [Example 42 on page 180](#)) maps to OMG IDL. This mapping uses a forward declaration of the `RecurSeq` IDL struct to define the recursive type.

**Example 43:** *IDL Mapping of a Self-Recursive Type*

```
// IDL
struct RecurSeq;
typedef sequence<RecurSeq> RecurSeqsArray;

struct RecurSeq {
  long long value;
  RecurSeqsArray RecurSeqs;
};
```

**Note:** Forward declaration of an OMG IDL struct is supported only by Orbix version and later.

## XML schema example of mutually-recursive types

[Example 44](#) shows an example of two mutually-recursive sequence types, `MutualSeqA` and `MutualSeqB`. In this example, `MutualSeqB` contains a reference to `MutualSeqA` and `MutualSeqA` contains a reference to `MutualSeqB`.

### Example 44: XML Example of Mutually-Recursive Types

```
<xsd:complexType name="MutualSeqA">
  <xsd:sequence>
    <xsd:element name="valueA" type="xsd:long"/>
    <xsd:element name="MutualSeqBs" type="s:MutualSeqB"
      minOccurs="0" maxOccurs="unbounded"/>
  </xsd:sequence>
</xsd:complexType>

<xsd:complexType name="MutualSeqB">
  <xsd:sequence>
    <xsd:element name="OneMutualSeqA" type="s:MutualSeqA"/>
    <xsd:element name="valueB" type="xsd:long"/>
  </xsd:sequence>
</xsd:complexType>
```

## IDL mapping of mutually-recursive types

[Example 45](#) shows how the mutually-recursive types, `MutualSeqA` and `MutualSeqB` (from [Example 44 on page 181](#)) map to OMG IDL. This mapping uses forward declarations of the `MutualSeqA` struct and the `MutualSeqB` struct, in order to define the recursive types.

### Example 45: IDL Mapping of Mutually-Recursive Types

```
// IDL
struct MutualSeqB;
struct MutualSeqA;
typedef sequence<MutualSeqB> MutualSeqBsArray;

struct MutualSeqA {
    long long valueA;
    MutualSeqBsArray MutualSeqBs;
};

struct MutualSeqB {
    MutualSeqA OneMutualSeqA;
    long long valueB;
};
```

---

# Endpoint References

## Overview

Endpoint references provide a convenient way of encapsulating the location of an Artix service, in a form that can be passed as a parameter or a return value in a WSDL operation. In the special case where the endpoint reference refers to a CORBA port, it is possible to map the endpoint reference to a CORBA object reference. It is obviously not possible for a CORBA client to use an object reference to connect to a non-CORBA service.

## Endpoint reference type

The endpoint reference type is defined by the WS-Addressing standard. In Artix, the endpoint reference type is normally represented as `wsa:EndpointReferenceType`.

## WS-Addressing namespace

Artix conventionally defines the namespace prefix, `wsa`, to represent the WS-Addressing namespace:

```
http://www.w3.org/2005/08/addressing
```

To use endpoint references, you should define the `wsa` namespace prefix in the `definitions` element of your WSDL contract.

## WS-Addressing schema import

In order to use endpoint references in a WSDL contract, you must also import the WS-Addressing schema, using the following import statement:

```
<import namespace="http://www.w3.org/2005/08/addressing"
  schemaLocation="WSAddressingURL"/>
```

Where `WSAddressingURL` can either be the path to an `.xsd` file in the local filesystem or a URL to retrieve the schema from a remote location.

## In this section

This section contains the following subsections:

<a href="#">Default Endpoint Reference Mapping</a>	page 183
<a href="#">Custom Endpoint Reference Mapping</a>	page 188

---

## Default Endpoint Reference Mapping

---

### Overview

By default, the endpoint reference type, `wsa:EndpointReferenceType`, maps to the IDL built-in type, `Object`.

---

### Using an endpoint reference type

To use an endpoint reference in your contract, simply declare a parameter or return value to be of `wsa:EndpointReferenceType` in an operation's request or reply message. For example, to declare the return value from a `create_account` operation to be an endpoint reference type, you would define the operation's request and reply messages as follows:

#### Example 46: Request and Reply Messages for `create_account` Operation

```
<message name="create_account">
  <part name="account_name" type="xsd:string"/>
</message>
<message name="create_accountResponse">
  <part name="return" type="wsa:EndpointReferenceType" />
</message>
```

---

### Empty endpoint reference

An *empty endpoint reference* is an endpoint reference that does not address any endpoint. Conventionally, the address of an empty endpoint reference is represented by the following URI:

```
http://www.w3.org/2005/08/addressing/none
```

Artix maps an empty endpoint reference to a CORBA nil object reference.

---

### WSDL example

[Example 47](#) shows how endpoint references are used in a bank WSDL contract. The Bank service exposes two operations, `create_account` and `get_account`, which return references to Account services. The returned references are declared to be of endpoint reference type, `wsa:EndpointReferenceType` (highlighted in bold font).

#### Example 47: Example Using Default Mapping of `EndpointReferenceType`

```
<definitions xmlns="http://schemas.xmlsoap.org/wsdl/"
  xmlns:soap="http://schemas.xmlsoap.org/wsdl/soap/"
  xmlns:tns="http://www.iona.com/bus/demos/bank"
  xmlns:xsd="http://www.w3.org/2001/XMLSchema"
```

**Example 47:** Example Using Default Mapping of EndpointReferenceType

```

xmlns:xsd1="http://soapinterop.org/xsd"
xmlns:stub="http://schemas.iona.com/transport/stub"
xmlns:http="http://schemas.iona.com/transport/http"
xmlns:http-conf="http://schemas.iona.com/transport/http/configuration"
xmlns:fixed="http://schemas.iona.com/binding/fixed"
xmlns:iiop="http://schemas.iona.com/transport/iiop_tunnel"
xmlns:corba="http://schemas.iona.com/binding/corba"
xmlns:ns1="http://www.iona.com/corba/typemap/BasePortType.idl"
xmlns:wsa="http://www.w3.org/2005/08/addressing"
xmlns:mq="http://schemas.iona.com/transport/mq"
xmlns:routing="http://schemas.iona.com/routing"
xmlns:msg="http://schemas.iona.com/port/messaging"
xmlns:bank="http://www.iona.com/bus/demos/bank"
targetNamespace="http://www.iona.com/bus/demos/bank"
name="BaseService" >
</types>

<schema elementFormDefault="qualified"
targetNamespace="http://www.iona.com/bus/demos/bank"
xmlns="http://www.w3.org/2001/XMLSchema">

<import namespace="http://www.w3.org/2005/08/addressing"
schemaLocation="wsaddressing.xsd"/>

<complexType name="AccountNames">
<sequence>
<element maxOccurs="unbounded" minOccurs="0" name="name" type="xsd:string"/>
</sequence>
</complexType>
</schema>
</types>

<message name="list_accounts" />
<message name="list_accountsResponse">
<part name="return" type="bank:AccountNames"/>
</message>

<message name="create_account">
<part name="account_name" type="xsd:string"/>
</message>
<message name="create_accountResponse">
<part name="return" type="wsa:EndpointReferenceType"/>
</message>

<message name="get_account">

```



**Example 47:** Example Using Default Mapping of EndpointReferenceType

```

xmlns:xsd1="http://soapinterop.org/xsd"
xmlns:stub="http://schemas.iona.com/transport/stub"
xmlns:http="http://schemas.iona.com/transport/http"
xmlns:http-conf="http://schemas.iona.com/transport/http/configuration"
xmlns:fixed="http://schemas.iona.com/binding/fixed"
xmlns:iiop="http://schemas.iona.com/transport/iiop_tunnel"
xmlns:corba="http://schemas.iona.com/binding/corba"
xmlns:ns1="http://www.iona.com/corba/typemap/BasePortType.idl"
xmlns:wsa="http://www.w3.org/2005/08/addressing"
xmlns:mq="http://schemas.iona.com/transport/mq"
xmlns:routing="http://schemas.iona.com/routing"
xmlns:msg="http://schemas.iona.com/port/messaging"
xmlns:bank="http://www.iona.com/bus/demos/bank"
targetNamespace="http://www.iona.com/bus/demos/bank"
name="BaseService" >
</types>

<schema elementFormDefault="qualified"
  targetNamespace="http://www.iona.com/bus/demos/bank"
  xmlns="http://www.w3.org/2001/XMLSchema">

  <import namespace="http://www.w3.org/2005/08/addressing"
    schemaLocation="wsaddressing.xsd"/>

  <complexType name="AccountNames">
    <sequence>
      <element maxOccurs="unbounded" minOccurs="0" name="name" type="xsd:string"/>
    </sequence>
  </complexType>
</schema>
</types>

<message name="list_accounts" />
<message name="list_accountsResponse">
  <part name="return" type="bank:AccountNames"/>
</message>

<message name="create_account">
  <part name="account_name" type="xsd:string"/>
</message>
<message name="create_accountResponse">
  <part name="return" type="wsa:EndpointReferenceType"/>
</message>

<message name="get_account">

```

**Example 47:** *Example Using Default Mapping of EndpointReferenceType*

```

    <part name="account_name" type="xsd:string"/>
  </message>
  <message name="get_accountResponse">
    <part name="return" type="wsa:EndpointReferenceType"/>
  </message>

  <message name="delete_account">
    <part name="account_name" type="xsd:string"/>
  </message>
  <message name="delete_accountResponse" />

  <message name="get_balance"/>
  <message name="get_balanceResponse">
    <part name="balance" type="xsd:float"/>
  </message>

  <message name="deposit">
    <part name="addition" type="xsd:float"/>
  </message>

  <message name="depositResponse"/>

  <portType name="Bank">

    <operation name="list_accounts">
      <input name="list_accounts" message="tns:create_account"/>
      <output name="list_accountsResponse" message="tns:list_accountsResponse"/>
    </operation>

    <operation name="create_account">
      <input name="create_account" message="tns:create_account"/>
      <output name="create_accountResponse" message="tns:create_accountResponse"/>
    </operation>

    <operation name="get_account">
      <input name="get_account" message="tns:get_account"/>
      <output name="get_accountResponse" message="tns:get_accountResponse"/>
    </operation>

    <operation name="delete_account">
      <input name="delete_account" message="tns:delete_account"/>
      <output name="delete_accountResponse" message="tns:delete_accountResponse"/>
    </operation>
  </portType>

```

**Example 47:** *Example Using Default Mapping of EndpointReferenceType*

```

</portType>
<portType name="Account">
  <operation name="get_balance">
    <input name="get_balance" message="tns:get_balance"/>
    <output name="get_balanceResponse" message="tns:get_balanceResponse"/>
  </operation>
  <operation name="deposit">
    <input name="deposit" message="tns:deposit"/>
    <output name="depositResponse" message="tns:depositResponse"/>
  </operation>
</portType>
...
</definitions>

```

**IDL mapping**

When the preceding WSDL contract ([Example 47 on page 183](#)) is mapped to OMG IDL, the Bank operations are mapped as shown in [Example 48](#).

**Example 48:** *Bank Interface with Default Endpoint Reference Mapping*

```

// IDL
interface Bank {
  ::AccountNames
  list_accounts(
    in string account_name
  );
  Object
  create_account(
    in string account_name
  );
  Object
  get_account(
    in string account_name
  );
  void
  delete_account(
    in string account_name
  );
};

```

## Custom Endpoint Reference Mapping

### Overview

Whereas in WSDL all endpoint references must be of the same type (that is, `wsa:EndpointReferenceType`), in IDL object references are usually declared as type specific. For example, if an IDL operation returns a reference to an account, the return value is normally defined to be of `Account` type, rather than the generic `Object` type.

To ensure that a WSDL endpoint reference maps to a type-specific object reference in IDL, you can add an annotation to the WSDL contract.

### Annotation for a custom endpoint reference mapping

To customize the mapping of an endpoint reference, you must modify the parameters in an operation's request or reply message to refer to a custom element instead of referring to a `wsa:EndpointReferenceType` type. The custom element must then be defined with an `xsd:annotation` element that contains details of the custom mapping.

For example, [Example 49](#) shows you how to define a reply message for the `create_account` operation from the Bank WSDL contract, such that the type returned from `create_account` maps to `Account` in IDL.

#### Example 49: Annotation for Custom Mapping of Endpoint Reference

```
<types>
  <schema ... >
    ...
    <element name="AccountRef"
      type="wsa:EndpointReferenceType">
      <annotation>
        <appinfo>corba:binding=AccountCORBABinding</appinfo>
      </annotation>
    </element>
  </schema>
</types>

<message name="create_account">
  <part name="account_name" type="xsd:string"/>
</message>
<message name="create_accountResponse">
  <part element="bank:AccountRef" name="return"/>
</message>
```

The annotation in the `AccountRef` element is defined in order to map the `wsa:EndpointReferenceType` to the `Account` interface. The setting in the `<appinfo>` tag:

```
corba:binding=BindingName
```

identifies an associated `Account` binding, rather than an `Account` port type, because the annotation applies specifically to the CORBA binding, not to all bindings.

## WSDL example

[Example 50](#) shows an example of a Bank WSDL contract that uses an annotation to customize the mapping of the endpoint reference type.

**Example 50:** *Example Using Custom Mapping of EndpointReferenceType*

```
<definitions xmlns="http://schemas.xmlsoap.org/wsdl/"
  xmlns:soap="http://schemas.xmlsoap.org/wsdl/soap/"
  xmlns:tns="http://www.ionas.com/bus/demos/bank"
  xmlns:xsd="http://www.w3.org/2001/XMLSchema"
  xmlns:xsdl="http://soapinterop.org/xsd"
  xmlns:stub="http://schemas.ionas.com/transport/stub"
  xmlns:http="http://schemas.ionas.com/transport/http"
  xmlns:http-conf="http://schemas.ionas.com/transport/http/configuration"
  xmlns:fixed="http://schemas.ionas.com/binding/fixed"
  xmlns:iiop="http://schemas.ionas.com/transport/iiop_tunnel"
  xmlns:corba="http://schemas.ionas.com/binding/corba"
  xmlns:ns1="http://www.ionas.com/corba/typemap/BasePortType.idl"
  xmlns:wsa="http://www.w3.org/2005/08/addressing"
  xmlns:mq="http://schemas.ionas.com/transport/mq"
  xmlns:routing="http://schemas.ionas.com/routing"
  xmlns:msg="http://schemas.ionas.com/port/messaging"
  xmlns:bank="http://www.ionas.com/bus/demos/bank"
  targetNamespace="http://www.ionas.com/bus/demos/bank"
  name="BaseService" >
  <types>
    <schema elementFormDefault="qualified"
      targetNamespace="http://www.ionas.com/bus/demos/bank"
      xmlns="http://www.w3.org/2001/XMLSchema">
      <import namespace="http://www.w3.org/2005/08/addressing"
        schemaLocation="wsaddressing.xsd"/>
      <complexType name="AccountNames">
        <sequence>
```

**Example 50:** *Example Using Custom Mapping of EndpointReferenceType*

```

        <element maxOccurs="unbounded" minOccurs="0" name="name" type="xsd:string"/>
    </sequence>
</complexType>

    <xsd:element name="AccountRef" type="wsa:EndpointReferenceType">
        <xsd:annotation>
            <xsd:appinfo:corba:binding=AccountCORBABinding/></xsd:appinfo>
        </xsd:annotation>
    </xsd:element>
</schema>
</types>

<message name="list_accounts" />
<message name="list_accountsResponse">
    <part name="return" type="bank:AccountNames"/>
</message>

<message name="create_account">
    <part name="account_name" type="xsd:string"/>
</message>
<message name="create_accountResponse">
    <part name="return" element="tns:AccountRef"/>
</message>

<message name="get_account">
    <part name="account_name" type="xsd:string"/>
</message>
<message name="get_accountResponse">
    <part name="return" element="tns:AccountRef"/>
</message>

<message name="delete_account">
    <part name="account_name" type="xsd:string"/>
</message>
<message name="delete_accountResponse" />

<message name="get_balance"/>
<message name="get_balanceResponse">
    <part name="balance" type="xsd:float"/>
</message>

<message name="deposit">
    <part name="addition" type="xsd:float"/>
</message>

```

**Example 50:** *Example Using Custom Mapping of EndpointReferenceType*

```

<message name="depositResponse"/>

<portType name="Bank">
  <operation name="list_accounts">
    <input name="list_accounts" message="tns:create_account"/>
    <output name="list_accountsResponse" message="tns:list_accountsResponse"/>
  </operation>

  <operation name="create_account">
    <input name="create_account" message="tns:create_account"/>
    <output name="create_accountResponse" message="tns:create_accountResponse"/>
  </operation>

  <operation name="get_account">
    <input name="get_account" message="tns:get_account"/>
    <output name="get_accountResponse" message="tns:get_accountResponse"/>
  </operation>

  <operation name="delete_account">
    <input name="delete_account" message="tns:delete_account"/>
    <output name="delete_accountResponse" message="tns:delete_accountResponse"/>
  </operation>

</portType>
<portType name="Account">
  <operation name="get_balance">
    <input name="get_balance" message="tns:get_balance"/>
    <output name="get_balanceResponse" message="tns:get_balanceResponse"/>
  </operation>
  <operation name="deposit">
    <input name="deposit" message="tns:deposit"/>
    <output name="depositResponse" message="tns:depositResponse"/>
  </operation>
</portType>
...
</definitions>

```

## Generating the IDL interfaces

To generate IDL from the WSDL contract shown in [Example 50 on page 189](#), perform the following steps:

1. Generate the CORBA binding for the Account interface, using the following command:

```
wsdltocorba -corba -i Account -b AccountCORBABinding  
bank.wsdl
```

Where the bank WSDL contract is stored in the file, `bank.wsdl`. The output from this command is a new WSDL file, `bank-corba.wsdl`, which includes the `AccountCORBABinding` binding.

2. Generate the CORBA binding for the Bank interface, using the following command:

```
wsdltocorba -corba -i Bank -b BankCORBABinding  
-o bank-corba2.wsdl bank-corba.wsdl
```

The output from this command is a new WSDL file, `bank-corba.wsdl`, which includes both the `AccountCORBABinding` binding and the `BankCORBABinding` binding.

**Note:** The order in which these two commands are issued is important, because the `BankCORBABinding` binding references the `AccountCORBABinding` binding.

3. Convert the WSDL contract with CORBA bindings into IDL, using the following command:

```
wsdltocorba -idl -b BankCORBABinding bank-corba2.wsdl
```



**CORBA type mapping**

[Example 51](#) shows the generated CORBA type mapping that results from adding both the `AccountCORBABinding` and the `BankCORBABinding` into the contract.

**Example 51: CORBA Type Mapping with References**

```
<corba:typeMapping
  targetNamespace="http://www.ionapro.com/bus/demos/bank/corba/typemap/">
  ...
  <corba:object binding="" name="Object"
    repositoryID="IDL:omg.org/CORBA/Object/1.0" type="wsa:EndpointReferenceType"/>
  <corba:object binding="AccountCORBABinding" name="Account"
    repositoryID="IDL:Account:1.0" type="wsa:EndpointReferenceType"/>
</corba:typeMapping>
```

There are two entries because `wsltdocorba` was run twice on the same file. The first CORBA object is generated from the first pass of `wsltdocorba` to generate the CORBA binding for `Account`. Because `wsltdocorba` could not find the binding specified in the annotation, it generated a generic `Object` reference. The second CORBA object, `Account`, is generated by the second pass when the binding for `Bank` was generated. On that pass, `wsltdocorba` could inspect the binding for the `Account` interface and generate a type-specific object reference.

**IDL mapping**

[Example 52](#) shows the IDL generated for the `Account` and `Bank` interfaces.

**Example 52: IDL Generated From Artix References**

```
//IDL
...
interface Account {
    float
    get_balance();
    void
    deposit(
        in float addition
    );
};
```

**Example 52:** *IDL Generated From Artix References (Continued)*

```
interface Bank {  
    :AccountNames  
    list_accounts(  
        in string account_name  
    );  
    :Account  
    create_account(  
        in string account_name  
    );  
    :Account  
    get_account(  
        in string account_name  
    );  
    void  
    delete_account(  
        in string account_name  
    );  
};
```

---

# Mapping to IDL Modules

## Overview

If you want your generated IDL files to be organised into modules, you can achieve this by applying the appropriate naming convention to the XML schema types that appear in the WSDL contract. The following aspects of IDL module mapping are discussed in this section:

- [Module mapping convention.](#)
- [References across modules.](#)
- [Circular references across modules.](#)

## Module mapping convention

In order to indicate to the Artix WSDL-to-IDL compiler that you want a type to appear inside an IDL module, give the type a local name with the following compound format:

```
ModuleName_1.ModuleName_2. . . .ModuleName_N.TypeName
```

Where Artix uses the period character, ., as a delimiter. *ModuleName\_1* to *ModuleName\_N* are the names of a series of nested IDL modules and *TypeName* is the unscoped type name in IDL.

For example, you can define an XML sequence type with the compound name, `ONE.SeqA`, as follows:

```
<xsd:complexType name="ONE.SeqA">
  <xsd:sequence>
    <xsd:element name="valueA" type="xsd:long"/>
  </xsd:sequence>
</xsd:complexType>
```

When you map this data type to IDL, you obtain a module, `ONE`, containing a struct definition, `SeqA`, as follows:

```
// IDL
module ONE {
  struct SeqA {
    long long valueA;
  };
};
```

**References across modules**

It is also possible to make references across modules. That is, a type defined in one module can use the elements or types defined in another module.

For example, you can define an XML sequence, `ONE.SeqA`, which has a member whose type is that of another sequence, `TWO.SeqB`, as follows:

```
<xsd:complexType name="ONE.SeqA">
  <xsd:sequence>
    <xsd:element name="valueA" type="xsd:long"/>
    <xsd:element name="seqB" type="s:TWO.SeqB"/>
  </xsd:sequence>
</xsd:complexType>

<xsd:complexType name="TWO.SeqB">
  <xsd:sequence>
    <xsd:element name="valueB" type="xsd:long"/>
  </xsd:sequence>
</xsd:complexType>
```

When you map the preceding types to IDL, the `seqB` member of the `SeqA` struct is of a type, `::TWO::SeqB`, that is defined in the second module, as follows:

```
// IDL
module ONE {
  struct SeqA {
    long long valueA;
    ::TWO::SeqB seqB;
  };
};
module TWO {
  struct SeqB {
    long long valueB;
  };
};
```

## Circular references across modules

Artix currently does *not* support the case where you have a chain of references between modules that form a closed loop.

For example, the following XML schema fragment—where the `ONE.SeqA` sequence references the `TWO.SeqB` sequence, which references the `ONE.SeqC` sequence—is not supported:

```
<xsd:complexType name="ONE.SeqA">
  <xsd:sequence>
    <xsd:element name="valueA" type="xsd:long"/>
    <xsd:element name="seqB" type="s:TWO.SeqB"/>
  </xsd:sequence>
</xsd:complexType>

<xsd:complexType name="TWO.SeqB">
  <xsd:sequence>
    <xsd:element name="seqC" type="s:ONE.SeqC"/>
    <xsd:element name="valueB" type="xsd:long"/>
  </xsd:sequence>
</xsd:complexType>

<xsd:complexType name="ONE.SeqC">
  <xsd:sequence>
    <xsd:element name="valueC" type="xsd:long"/>
  </xsd:sequence>
</xsd:complexType>
```

If you map the preceding WSDL example to IDL, and then map the IDL to C++, you obtain stub code that is *not* compilable (the IDL is missing a forward reference to a struct).



# Monitoring GIOP Message Content

*Artix includes the GIOP Snoop tool for intercepting and displaying GIOP message content.*

**WARNING:** It is recommended that you avoid using this feature in secure applications. The GIOP snoop plug-in can expose user names and passwords.

## In this chapter

---

This chapter contains the following sections:

<a href="#">Introduction to GIOP Snoop</a>	<a href="#">page 200</a>
<a href="#">Configuring GIOP Snoop</a>	<a href="#">page 201</a>
<a href="#">GIOP Snoop Output</a>	<a href="#">page 204</a>

---

# Introduction to GIOP Snoop

---

## Overview

GIOP Snoop is a GIOP protocol level plug-in for intercepting and displaying GIOP message content. This plug-in implements message level interceptors that can participate in client and/or server side bindings over any GIOP-based transport. The primary purposes of GIOP Snoop are to provide a protocol level monitor and debug aid.

**WARNING:** It is recommended that you avoid using this feature in secure applications. The GIOP snoop plug-in can expose user names and passwords.

## GIOP plug-ins

The primary protocol for inter-ORB communications is the General Inter-ORB Protocol (GIOP) as defined the CORBA Specification.



---

# Configuring GIOP Snoop

---

## Overview

GIOP Snoop can be configured for debugging in client, server, or both depending on configuration. This section includes the following configuration topics:

- [Loading the GIOP Snoop plug-in.](#)
- [Client-side snooping.](#)
- [Server-side snooping.](#)
- [GIOP Snoop verbosity levels.](#)
- [Directing output to a file.](#)

---

## Loading the GIOP Snoop plug-in

For either client or server configuration, the GIOP Snoop plug-in must be included in the Orbix `orb_plugins` list (`...` denotes existing configured settings):

```
orb_plugins = [..., "giop_snoop", ...];
```

In addition, the `giop_snoop` plug-in must be located and loaded using the following settings:

```
# Artix Configuration File
plugins:giop_snoop:shlib_name = "it_giop_snoop";
```

---

**Client-side snooping**

To enable client-side snooping, include the `GIOP_SNOOP` factory in the client binding list. In this example, GIOP Snoop is enabled for IIOP-specific bindings:

```
binding:client_binding_list =
    [..., "GIOP+GIOP_SNOOP+IIOP", ...];
```

---

**Server-side snooping**

To enable server-side snooping, include the `GIOP_SNOOP` factory in the server binding list.

```
plugins:giop:message_server_binding_list =
    [..., "GIOP_SNOOP+GIOP", ...];
```

---

**GIOP Snoop verbosity levels**

You can use the following variable to control the GIOP Snoop verbosity level:

```
plugins:giop_snoop:verbosity = "1";
```

The verbosity levels are as follows:

- |   |           |
|---|-----------|
| 1 | LOW       |
| 2 | MEDIUM    |
| 3 | HIGH      |
| 4 | VERY HIGH |

These verbosity levels are explained with examples in [“GIOP Snoop Output” on page 204](#).

## Directing output to a file

---

By default, output is directed to standard error (`stderr`). However, you can specify an output file using the following configuration variable:

```
plugins:giop_snoop:filename = "<some-file-path>";
```

A month/day/year time stamp is included in the output filename with the following general format:

```
<filename>.MMDDYYYY
```

As a result, for a long running application, each day results in the creation of a new log file. To enable administrators to control the size and content of output files GIOP Snoop does not hold output files open. Instead, it opens and then closes the file for each snoop message trace. This setting is enabled with:

```
plugins:giop_snoop:rolling_file = "true";
```

**WARNING:** It is recommended that you avoid logging GIOP messages in secure applications. The GIOP snoop plug-in can expose user names and passwords.

# GIOP Snoop Output

## Overview

The output shown in this section uses a simple example that shows client-side output for a single binding and operation invocation. The client establishes a client-side binding that involves a message interceptor chain consisting of IIOP, GIOP Snoop, and GIOP. The client then connects to the server and first sends a `[LocateRequest]` to the server to test if the target object is reachable. When confirmed, a two-way invocation `[Request]` is sent, and the server processes the request. When complete, the server sends a `[Reply]` message back to the client.

Output detail varies depending on the configured verbosity level. With level 1 (`LOW`), only basic message type, direction, operation name and some GIOP header information (version, and so on) is given. More detailed output is possible, as described under the following examples.

## LOW verbosity client-side snooping

An example of `LOW` verbosity output is as follows:

```
[Conn:1] Out: (first for binding) [LocateRequest] MsgLen: 39 ReqId: 0
[Conn:1] In: (first for binding) [LocateReply] MsgLen: 8 ReqId: 0
        Locate status: OBJECT_HERE
[Conn:1] Out: [Request] MsgLen: 60 ReqId: 1 (two-way)
        Operation (len 8) 'null_op'
[Conn:1] In: [Reply] MsgLen: 12 ReqId: 1
        Reply status (0) NO_EXCEPTION
```

This example shows an initial conversation from the client-side perspective. The client transmits a `[LocateRequest]` message to which it receives a `[LocateReply]` indicates that the server supports the target object. It then makes an invocation on the operation `null_op`.

The `Conn` indicates the logical connection. Because GIOP may be mapped to multiple transports, there is no transport specific information visible to interceptors above the transport (such as file descriptors) so each connection is given a logical identifier. The first incoming and outgoing GIOP message to pass through each connection are indicated by `(first for binding)`.

The direction of the message is given (Out for outgoing, In for incoming), followed by the GIOP and message header contents. Specific information includes the GIOP version (version 1.2 above), message length and a unique request identifier (ReqId), which associates [LocateRequest] messages with their corresponding [LocateReply] messages. The (two-way) indicates the operation is two way and a response (Reply) is expected. String lengths such as len 8 specified for Operation includes the trailing null.

### MEDIUM verbosity client-side snooping

An example of MEDIUM verbosity output is as follows:

```
16:24:39 [Conn:1] Out: (first for binding) [LocateRequest]   GIOP v1.2  MsgLen: 39
  Endian: big  ReqId: 0
  Target Address (0: KeyAddr)
  ObjKey (len 27) ':>.11.....\..A.....'

16:24:39 [Conn:1] In: (first for binding) [LocateReply]     GIOP v1.2  MsgLen: 8
  Endian: big  ReqId: 0
  Locate status: OBJECT_HERE

16:24:39 [Conn:1] Out: [Request]                       GIOP v1.2  MsgLen: 60
  Endian: big  ReqId: 1 (two-way)
  Target Address (0: KeyAddr)
  ObjKey (len 27) ':>.11.....\..A.....'
  Operation (len 8) 'null_op'

16:24:39 [Conn:1] In: [Reply]                           GIOP v1.2  MsgLen: 12
  Endian: big  ReqId: 1
  Reply status (0) NO_EXCEPTION
```

For MEDIUM verbosity output, extra information is provided. The addition of time stamps (in *hh:mm:ss*) precedes each snoop line. The byte order of the data is indicated (Endian) along with more detailed header information such as the target address shown in this example. The target address is a GIOP 1.2 addition in place of the previous object key data.

**HIGH verbosity client side snooping**

The following is an example of HIGH verbosity output:

```

16:24:39 [Conn:1] Out:(first for binding) [LocateRequest]      GIOP v1.2  MsgLen: 39
  Endian: big ReqId: 0
  Target Address (0: KeyAddr)
    ObjKey (len 27) ':>.11.....A.....'
  GIOP Hdr (len 12): [47] [49] [4f] [50] [01] [02] [00] [03] [00] [00] [27]
  Msg Hdr (len 39): [00] [00] [00] [00] [00] [00] [00] [00] [00] [00] [00] [00] [1b] [3a] [3e]
 [02] [31] [31] [0c] [00] [00] [00] [00] [00] [00] [00] [00] [0f] [05] [00] [00] [41] [c6] [08] [00] [00] [00]
 [00] [00] [00] [00] [00]
  [---- end of message ----]

16:31:37 [Conn:1] In: (first for binding) [LocateReply]      GIOP v1.2  MsgLen: 8
  Endian: big ReqId: 0
  Locate status: OBJECT_HERE
  GIOP Hdr (len 12): [47] [49] [4f] [50] [01] [02] [00] [04] [00] [00] [00] [08]
  Msg Hdr (len 8): [00] [00] [00] [00] [00] [00] [00] [01]
  [---- end of message ----]

16:31:37 [Conn:1] Out: [Request]                          GIOP v1.2  MsgLen: 60
  Endian: big ReqId: 1 (two-way)
  Target Address (0: KeyAddr)
    ObjKey (len 27) ':>.11.....A.....'
  Operation (len 8) 'null_op'
  No. of Service Contexts: 0
  GIOP Hdr (len 12): [47] [49] [4f] [50] [01] [02] [00] [00] [00] [00] [00] [3c]
  Msg Hdr (len 60): [00] [00] [00] [01] [03] [00] [00] [00] [00] [00] [00] [00] [00] [00] [00]
 [00] [1b] [3a] [3e] [02] [31] [31] [0c] [00] [00] [00] [00] [00] [00] [0f] [05] [00] [00] [41] [c6]
 [08] [00] [00] [00] [00] [00] [00] [00] [00] [00] [00] [00] [00] [00] [08] [6e] [75] [6c] [6c] [5f] [6f]
 [70] [00] [00] [00] [00] [00]
  [---- end of message ----]

16:31:37 [Conn:1] In: [Reply]                            GIOP v1.2  MsgLen: 12
  Endian: big ReqId: 1
  Reply status (0) NO_EXCEPTION
  No. of Service Contexts: 0
  GIOP Hdr (len 12): [47] [49] [4f] [50] [01] [02] [00] [01] [00] [00] [00] [0c]
  Msg Hdr (len 12): [00] [00] [00] [01] [00] [00] [00] [00] [00] [00] [00] [00]
  [---- end of message ----]

```

This level of verbosity includes all header data, such as service context data. ASCII-hex pairs of GIOP header and message header content are given to show the exact on-the-wire header values passing through the interceptor. Messages are also separated showing inter-message boundaries.

**VERY HIGH verbosity client side snooping**

---

This is the highest verbosity level available. Displayed data includes `HIGH` level output and in addition the message body content is displayed. Because the plug-in does not have access to IDL interface definitions, it does not know the data types contained in the body (parameter values, return values and so on) and simply provides ASCII-hex output. Body content display is truncated to a maximum of 4 KB with no output given for an empty body. Body content output follows the header output, for example:

```
...
GIOP Hdr (len 12): [47] [49] [4f] [50] [01] [02] [00] [01] [00] [00] [00] [0c]
Msg Hdr   (len 12): [00] [00] [00] [01] [00] [00] [00] [00] [00] [00] [00] [00]
Msg Body (len <x>): <content>
...
```





# Configuring a CORBA Binding

*CORBA bindings are described using a variety of IONA-specific WSDL elements within the WSDL binding element. In most cases, the CORBA binding description is generated automatically using the `wsdltoCORBA` utility. Usually, it is unnecessary to modify generated CORBA bindings.*

**Namespace**

---

The WSDL extensions used to describe CORBA data mappings and CORBA transport details are defined in the WSDL namespace

`http://schemas.iona.com/bindings/corba`. To use the CORBA extensions you will need to include the following in the `<definitions>` tag of your contract:

```
xmlns:corba="http://schemas.iona.com/bindings/corba"
```

---

**corba:binding element**

The `corba:binding` element indicates that the binding is a CORBA binding. This element has one required attribute: `repositoryID`. `repositoryID` specifies the full type ID of the interface. The type ID is embedded in the object's IOR and therefore must conform to the IDs that are generated from an IDL compiler. These are of the form:

```
IDL:module/interface:1.0
```

The `corba:binding` element also has an optional attribute, `bases`, that specifies that the interface being bound inherits from another interface. The value for `bases` is the type ID of the interface from which the bound interface inherits. For example, the following IDL:

```
//IDL
interface clash{};
interface bad : clash{};
```

would produce the following `corba:binding`:

```
<corba:binding repositoryID="IDL:bad:1.0"
    bases="IDL:clash:1.0"/>
```

---

**corba:operation element**

The `corba:operation` element is an IONA-specific element of `<operation>` and describes the parts of the operation's messages. `<corba:operation>` takes a single attribute, `name`, which duplicates the name given in `<operation>`.

---

**corba:param element**

The `corba:param` element is a member of `<corba:operation>`. Each `<part>` of the input and output messages specified in the logical operation, except for the part representing the return value of the operation, must have a

corresponding `<corba:param>`. The parameter order defined in the binding must match the order specified in the IDL definition of the operation.

`<corba:param>` has the following required attributes:

<code>mode</code>	Specifies the direction of the parameter. The values directly correspond to the IDL directions: <code>in</code> , <code>inout</code> , <code>out</code> . Parameters set to <code>in</code> must be included in the input message of the logical operation. Parameters set to <code>out</code> must be included in the output message of the logical operation. Parameters set to <code>inout</code> must appear in both the input and output messages of the logical operation.
<code>idltype</code>	Specifies the IDL type of the parameter. The type names are prefaced with <code>corba:</code> for primitive IDL types, and <code>corbatm:</code> for complex data types, which are mapped out in the <code>corba:typeMapping</code> portion of the contract.
<code>name</code>	Specifies the name of the parameter as given in the logical portion of the contract.

---

#### **corba:return element**

The `corba:return` element is a member of `<corba:operation>` and specifies the return type, if any, of the operation. It only has two attributes:

<code>name</code>	Specifies the name of the parameter as given in the logical portion of the contract.
<code>idltype</code>	Specifies the IDL type of the parameter. The type names are prefaced with <code>corba:</code> for primitive IDL types and <code>corbatm:</code> for complex data types which are mapped out in the <code>corba:typeMapping</code> portion of the contract.

---

#### **corba:raises element**

The `corba:raises` element is a member of `<corba:operation>` and describes any exceptions the operation can raise. The exceptions are defined as fault messages in the logical definition of the operation. Each fault message must have a corresponding `corba:raises` element. The `corba:raises` element has one required attribute, `exception`, which specifies the type of data returned in the exception.

In addition to operations specified in `<corba:operation>` tags, within the `<operation>` block, each `<operation>` in the binding must also specify empty `input` and `output` elements as required by the WSDL specification. The CORBA binding specification, however, does not use them.

For each fault message defined in the logical description of the operation, a corresponding `fault` element must be provided in the `<operation>`, as required by the WSDL specification. The `name` attribute of the `fault` element specifies the name of the schema type representing the data passed in the fault message.

## Example

For example, a logical interface for a system to retrieve employee information might look similar to `personalInfoLookup`, shown in [Example 53](#).

### Example 53: *personalInfo lookup port type*

```
<message name="personalLookupRequest">
  <part name="empId" type="xsd:int" />
</message />
<message name="personalLookupResponse">
  <part name="return" element="xsd1:personalInfo" />
</message />
<message name="idNotFoundException">
  <part name="exception" element="xsd1:idNotFound" />
</message />
<portType name="personalInfoLookup">
  <operation name="lookup">
    <input name="empID" message="personalLookupRequest" />
    <output name="return" message="personalLookupResponse" />
    <fault name="exception" message="idNotFoundException" />
  </operation>
</portType>
```

The CORBA binding for `personalInfoLookup` is shown in [Example 54](#).

**Example 54:** *personalInfoLookup CORBA Binding*

```
<binding name="personalInfoLookupBinding" type="tns:personalInfoLookup">
  <corba:binding repositoryID="IDL:personalInfoLookup:1.0"/>
  <operation name="lookup">
    <corba:operation name="lookup">
      <corba:param name="empId" mode="in" idltype="corba:long"/>
      <corba:return name="return" idltype="corbatm:personalInfo"/>
      <corba:raises exception="corbatm:idNotFound"/>
    </corba:operation>
  </operation>
  <input/>
  <output/>
  <fault name="personalInfoLookup.idNotFound"/>
</binding>
```



# Configuring a CORBA Port

*CORBA ports are described using the IONA-specific WSDL elements, `corba:address` and `corba:policy`, within the WSDL port element, to specify how a CORBA object is exposed.*

**Namespace**

[Example 55](#) shows the namespace entries you need to add to the `definitions` element of your contract to use the CORBA extensions.

**Example 55:** *Artix CORBA Extension Namespaces*

```
<definitions
  ...
  xmlns:iiop="http://schemas.iona.com/bindings/corba"
  ... >
```

**corba:address element**

The IOR of the CORBA object is specified using the `corba:address` element. You have four options for specifying IORs in Artix contracts:

- Specify the object's IOR directly, by entering the object's IOR directly into the contract using the stringified IOR format:

```
IOR:22342....
```

- Specify a file location for the IOR, using the following syntax:

```
file:///file_name
```

**Note:** The file specification requires three backslashes (`///`).

It is usually simplest to specify the file name using an absolute path. If you specify the file name using a relative path, the location is taken to be relative to the directory the Artix process is started in, *not* relative to the containing WSDL file.

- Specify that the IOR is published to a CORBA name service, by entering the object's name using the `corbaname` format:

```
corbaname:rir/NameService#object_name
```

For more information on using the name service with Artix see *Deploying and Managing Artix Solutions*.

- Specify the IOR using `corbaloc`, by specifying the port at which the service exposes itself, using the `corbaloc` syntax.

```
corbaloc:iiop:host:port/service_name
```



When using `corbaloc`, you must be sure to configure your service to start up on the specified host and port.

## **corba:policy element**

Using the optional `corba:policy` element, you can describe a number of POA policies the Artix service will use when creating the POA for connecting to a CORBA application. These policies include:

- [POA Name](#).
- [Persistence](#).
- [ID Assignment](#).

Setting these policies lets you exploit some of the enterprise features of IONA's Orbix 6.x, such as load balancing and fault tolerance, when deploying an Artix integration project. For information on using these advanced CORBA features, see the Orbix documentation.

### **POA Name**

By default, an Artix POA is created with the default name, `{ServiceNamespace}ServiceLocalPart#PortName`. For example, if a CORBA port is defined by the following WSDL fragment:

```
<definitions
  ...
  xmlns:corbatm="http://iona.com/mycorbaservice" >

  <service name="CorbaService">
    <port binding="corbatm:CorbaBinding" name="CorbaPort">
      <corba:address
        location="file:../../hello_world_service.ior"/>
    </port>
  </service>
  ...
```

The unique POA name automatically generated for this CORBA port is `{http://iona.com/mycorbaservice}CorbaService#CorbaPort`.

Alternatively, you can specify the POA name explicitly by setting the `poaname` attribute, as follows:

```
<corba:policy poaname="poa_name" />
```

When setting a POA name using the `poaname` attribute, it is your responsibility to ensure that the POA name is unique. That is, the POA name should *not* be shared between CORBA ports within a service or across CORBA services.

### Persistence

By default Artix POA's have a persistence policy of `false`. To set the POA's persistence policy to `true`, use the following:

```
<corba:policy persistent="true" />
```

### ID Assignment

By default Artix POAs are created with a `SYSTEM_ID` policy, meaning that their ID is assigned by the ORB. To specify that the POA connecting a specific object should use a user-assigned ID, use the following:

```
<corba:policy serviceid="POAid" />
```

This creates a POA with a `USER_ID` policy and an object id of `POAid`.

## Example

For example, a CORBA port for the `personalInfoLookup` binding would look similar to [Example 56](#):

### Example 56: CORBA *personalInfoLookup* Port

```
<service name="personalInfoLookupService">
  <port name="personalInfoLookupPort"
    binding="tns:personalInfoLookupBinding">
    <corba:address location="file:///objref.ior" />
    <corba:policy persistent="true" />
    <corba:policy serviceid="personalInfoLookup" />
  </port>
</service>
```

Artix expects the IOR for the CORBA object to be located in a file called `objref.ior` (relative to the directory in which the Artix process is started), and creates a persistent POA with an object id of `personalInfo` to connect the CORBA application.



# CORBA Utilities in Artix

*Use the `idltowSDL` utility to convert OMG IDL to WSDL and use the `wSDLtoCORBA` utility to generate CORBA bindings and to convert WSDL to OMG IDL.*

---

## In this chapter

This chapter discusses the following topics:

<a href="#">Generating a CORBA Binding</a>	<a href="#">page 222</a>
<a href="#">Converting WSDL to OMG IDL</a>	<a href="#">page 223</a>
<a href="#">Converting OMG IDL to WSDL</a>	<a href="#">page 224</a>

---

# Generating a CORBA Binding

## Overview

The `wsdltocorba` utility can perform two distinct tasks:

- Generate a CORBA binding.
- Convert WSDL to OMG IDL.

This section discusses how to use the `wsdltocorba` utility to add a CORBA binding to an existing WSDL contract.

---

## WSDLTOCORBA

### Synopsis

```
wsdltocorba -corba -i port-type [-d directory] [-o file]
[-props namespace] [-?] [-v] [-verbose] wSDL_file
```

### Options

The command has the following options:

<code>-corba</code>	Instructs the tool to generate a CORBA binding for the specified port type.
<code>-i <i>port-type</i></code>	Specifies the name of the port type being mapped to a CORBA binding.
<code>-d <i>directory</i></code>	Specifies the directory into which the new WSDL file is written.
<code>-o <i>file</i></code>	Specifies the name of the generated WSDL file. Defaults to <code><i>wSDL_file</i>-corba.wsdl</code> .
<code>-props <i>namespace</i></code>	Specifies the target namespace for the <code>corba:typeMapping</code> element (an element that defines the WSDL-to-IDL mappings for complex types).
<code>-?</code>	Display detailed information about the options.
<code>-v</code>	Display the version of the utility.
<code>-verbose</code>	Write a detailed log to standard output while the utility is running.

---

# Converting WSDL to OMG IDL

---

## Overview

The `wsdltocorba` utility can perform two distinct tasks:

- Generate a CORBA binding.
- Convert WSDL to OMG IDL.

This section discusses how to use the `wsdltocorba` utility to convert a WSDL contract into an OMG IDL file.

---

## WSDLTOCORBA

### Synopsis

```
wsdltocorba -idl -b binding [-d directory] [-o file] [-?] [-v]
[-verbose] wSDL_file
```

### Options

The command has the following options:

<code>-idl</code>	Instructs the tool to generate an IDL file from the specified binding.
<code>-b <i>binding</i></code>	Specifies the CORBA binding from which to generate IDL.
<code>-d <i>directory</i></code>	Specifies the directory into which the new IDL file is written.
<code>-o <i>file</i></code>	Specifies the name of the generated IDL file. Defaults to <code>wSDL_file.idl</code> .
<code>-?</code>	Display detailed information about the options.
<code>-v</code>	Display the version of the utility.
<code>-verbose</code>	Write a detailed log to standard output while the utility is running.

---

# Converting OMG IDL to WSDL

---

## Overview

IONA's IDL compiler supports several command line flags that specify how to create a WSDL file from an IDL file. The default behavior of the tool is to create WSDL file that uses wrapped doc/literal style messages. Wrapped doc/literal style messages have a single part, defined using an element that wraps all of the elements in the message.

---

## IDLTOWSDL

### Synopsis

```
idltowSDL [ -I idl-include-directory ]* [ -3 ] [ -o output-directory ]
[ -a corba-address ] [ -b ] [ -f corba-address-file ] [ -n
schema-import-file ] [ -s idl-sequence-type ] [ -w target-namespace ]
[ -x schema-namespace ] [ -t type-map-namespace ] [ -useTypes ]
[ -unwrap ] [ -r reference-schema-file ] [ -L logical-wsdl-file ]
[ -P physical-wsdl-file ] [ -T schema-file-name ] [ -fasttrack ] [
-interface interface-name ] [ -soapaddr soap-port-address ] [
-qualified ] [ -inline ] [ -e xml-encoding-type ] [ -? ] [ -v ] [
-verbose ] IDLFile
```

### Options

The command has the following options:

- `-I idl-include-directory` Specify a directory to be included in the search path for the IDL preprocessor.
- `-3` Select parsing mode for compatibility with legacy Orbix 3 IDL files.
- `-o output-directory` Specifies the directory into which the WSDL file is written.
- `-a corba-address` Specifies an absolute address through which the object reference may be accessed. The *corba-address* may be a relative or absolute path to a file, or a corbaname URL
- `-b` Specifies that bounded strings are to be treated as unbounded. This eliminates the generation of the special types for the bounded string.



- f *corba-address-file* Specifies a file containing a string representation of an object reference. The object reference is placed in the `corba:address` element in the `<port>` definition of the generated service. The *corba-address-file* must exist when you run the `idltowsdl` utility.
- n *schema-import-file* Specifies that a schema file, *schema-import-file*, is to be included in the generated contract by an import statement. This option cannot be used with the `-T` option.
- s *idl-sequence-type* Specifies the XML schema type used to map the IDL `sequence<octet>` type. Valid values are `base64Binary` or `hexBinary`. The default is `base64Binary`.
- w *target-namespace* Specifies the namespace to use for the WSDL `targetNamespace`. The default is `http://schemas.ionac.com/idl/IDLFile`.
- x *schema-namespace* Specifies the namespace to use for the Schema `targetNamespace`. The default is `http://schemas.ionac.com/idltypes/IDLFile`.
- t *type-map-namespace* Specifies the namespace to use for the CORBA `TypeMapping targetNamespace`. The default is `http://schemas.ionac.com/typemap/corba/IDLFile`.
- useTypes Generate rpc style messages. rpc style messages have parts defined using XMLSchema types instead of XML elements.
- unwrap Generate unwrapped doc/literal messages. Unwrapped messages have parts that represent individual elements. Unlike wrapped messages, unwrapped messages can have multiple parts and are not allowed by the WS-I.
- r *reference-schema-file* Specify the pathname of the schema file imported to define the `wsa:EndpointReference` type. If the `-r` option is not given, the `idl` compiler gets the schema file pathname from the `AddressingSchemaLocation` setting in `etc/idl.cfg`.

<code>-L</code> <i>logical-wsdl-file</i>	Specifies that the logical portion of the generated WSDL specification into is written to <i>logical-wsdl-file</i> . The <i>logical-wsdl-file</i> is then imported into the default generated file.
<code>-P</code> <i>physical-wsdl-filen</i>	Specifies that the physical portion of the generated WSDL specification into is written to <i>physical-wsdl-file</i> . The <i>physical-wsdl-file</i> is then imported into the default generated file.
<code>-T</code> <i>schema-file-name</i>	Specifies that the schema types are to be generated into a separate file. The schema file is included in the generated contract using an import statement. This option cannot be used with the <code>-n</code> option.
<code>-fasttrack</code>	Provides a fast way of generating a router contract for a router that converts incoming SOAP/HTTP messages into CORBA invocations. The <code>-interface</code> option must always be specified when <code>-fasttrack</code> is used.
<code>-interface</code> <i>interface-name</i>	Used in combination with the <code>-fasttrack</code> option to specify the IDL interface that is exposed through the generated router contract.
<code>-soapaddr</code> <i>soap-port-address</i>	Used in combination with the <code>-fasttrack</code> option to specify the address of the generated SOAP port. The address is specified in the format <i>Host:Port</i> .
<code>-qualified</code>	Generate the schemas in the WSDL contract with the <code>elementFormDefault</code> and <code>attributeFormDefault</code> attributes set to <code>qualified</code> . This implies that elements and attributes appearing in instance documents must be explicitly qualified by a namespace.
<code>-inline</code>	Normally, when you specify a schema file using the <code>-n</code> option, the schema is imported by a generated <code>xsd:import</code> element, which sets the <code>schemaLocation</code> attribute. If you specify the <code>-inline</code> option, however, the schema is included directly in the generated WSDL contract and the generated <code>xsd:import</code> element omits the <code>schemaLocation</code> attribute.

<code>-e xml-encoding-type</code>	Use the specified WSDL encoding for the value of the <code>encoding</code> attribute in the generated <code>&lt;?xml ... ?&gt;</code> tag. The default is UTF-8.
<code>-?</code>	Display detailed information about the options.
<code>-v</code>	Display the version of the utility.
<code>-verbose</code>	Write a detailed log to standard output while the utility is running.

**Note:** The command line flag entries are case sensitive even on Windows. Capitalization in your generated WSDL file must match the capitalization used in the prewritten code.

### Orbis 3 legacy compatibility

To address some issues associated with Orbis 3 migration, the Artix IDL compiler supports a `-3` option, which causes the following behavior in the `idltowsdl` utility:

- Case sensitivity is activated—this means that name lookup during parsing is case sensitive. While technically incorrect according to the CORBA specification, some legacy IDL files might require case sensitivity. The IDL compiler issues warnings, if case sensitivity rules are broken.
- New IDL keywords added since CORBA 2.3 (for example, `factory` and `local`) are treated as ordinary identifiers, but warnings are issued.
- If a different spelling of the keyword `object` is encountered (for example, `object`, `OBJECT`, or `oBJEcT`), it is treated as an identifier, and a warning is issued.
- All IDL is preprocessed with the additional flag `-DIT_ORBIX3IDL_COMPATIBILITY`. This allows IDL definitions to make use of this macro in `#ifdefs` to help with migration issues.
- Unscoped types from the `CORBA` module—legacy IDL often uses `TypeCode` as a global type, whereas the IDL specification requires it to be properly scoped to the `CORBA` module. To deal with this issue, you could use the following `#ifdef` to bring `TypeCode` into global scope, if required:

```
#ifdef IT_ORBIX3IDL_COMPATIBILITY
typedef CORBA::TypeCode TypeCode;
```

```
#endif
```

**Note:** `TypeCode` originally was a global type in CORBA, but the CORBA module was added around 1992/1993 to scope such types.)

- Semicolons are tolerated in `#include` statements. The IDL compiler removes the semicolons and issues a warning.
- Opaque types—there are no easy migration solutions for opaque types. The IDL compiler does not recognize the `opaque` keyword. If you have legacy IDL that uses opaque types, you should consider migrating them to something like a `valuetype` instead.

# Mapping CORBA Exceptions

*To facilitate interoperability between CORBA applications and Artix applications, Artix automatically maps between CORBA system exceptions and Artix faults.*

---

## **In this appendix**

This appendix discusses the following topics:

<a href="#">Mapping from CORBA System Exceptions</a>	page 230
<a href="#">Mapping from Fault Categories</a>	page 232
<a href="#">Mapping of Completion Status</a>	page 233

# Mapping from CORBA System Exceptions

## Overview

When a CORBA system exception is returned from a CORBA server to an Artix client, Artix automatically converts the CORBA system exception to a fault category.

## Map from CORBA system exceptions to fault categories

Table 5 shows how each of the major CORBA system exceptions map to Artix fault categories.

**Table 5:** *Map from CORBA System Exceptions to Fault Categories*

CORBA System Exception	Fault Category
CORBA::BAD_CONTEXT	IT_Bus::FaultCategory::INTERNAL
CORBA::BAD_INV_ORDER	IT_Bus::FaultCategory::INTERNAL
CORBA::BAD_OPERATION	IT_Bus::FaultCategory::BAD_OPERATION
CORBA::BAD_TYPECODE	IT_Bus::FaultCategory::MARSHAL_ERROR
CORBA::BAD_QOS	IT_Bus::FaultCategory::INTERNAL
CORBA::CODESET_INCOMPATIBLE	IT_Bus::FaultCategory::MARSHAL_ERROR
CORBA::COMM_FAILURE	IT_Bus::FaultCategory::CONNECTION_FAILURE
CORBA::DATA_CONVERSION	IT_Bus::FaultCategory::MARSHAL_ERROR
CORBA::FREE_MEM	IT_Bus::FaultCategory::MEMORY
CORBA::IMP_LIMIT	IT_Bus::FaultCategory::INTERNAL
CORBA::INITIALIZE	IT_Bus::FaultCategory::UNKNOWN
CORBA::INTERNAL	IT_Bus::FaultCategory::INTERNAL
CORBA::INTF_REPOS	IT_Bus::FaultCategory::INTERNAL
CORBA::INV_FLAG	IT_Bus::FaultCategory::INTERNAL
CORBA::INV_IDENT	IT_Bus::FaultCategory::NOT_EXIST

**Table 5:** *Map from CORBA System Exceptions to Fault Categories*

<b>CORBA System Exception</b>	<b>Fault Category</b>
CORBA::INV_OBJREF	IT_Bus::FaultCategory::INVALID_REFERENCE
CORBA::INV_POLICY	IT_Bus::FaultCategory::INTERNAL
CORBA::INVALID_TRANSACTION	IT_Bus::FaultCategory::INTERNAL
CORBA::MARSHAL	IT_Bus::FaultCategory::MARSHAL_ERROR
CORBA::NO_IMPLEMENT	IT_Bus::FaultCategory::NOT_IMPLEMENTED
CORBA::NO_MEMORY	IT_Bus::FaultCategory::MEMORY
CORBA::NO_PERMISSION	IT_Bus::FaultCategory::NO_PERMISSION
CORBA::NO_RESOURCES	IT_Bus::FaultCategory::INTERNAL
CORBA::NO_RESPONSE	IT_Bus::FaultCategory::INTERNAL
CORBA::OBJ_ADAPTER	IT_Bus::FaultCategory::INTERNAL
CORBA::OBJECT_NOT_EXIST	IT_Bus::FaultCategory::NOT_EXIST
CORBA::PERSIST_STORE	IT_Bus::FaultCategory::INTERNAL
CORBA::REBIND	IT_Bus::FaultCategory::INTERNAL
CORBA::TIMEOUT	IT_Bus::FaultCategory::TIMEOUT
CORBA::TRANSACTION_MODE	IT_Bus::FaultCategory::INTERNAL
CORBA::TRANSACTION_REQUIRED	IT_Bus::FaultCategory::INTERNAL
CORBA::TRANSACTION_ROLLEDBACK	IT_Bus::FaultCategory::INTERNAL
CORBA::TRANSACTION_UNAVAILABLE	IT_Bus::FaultCategory::INTERNAL
CORBA::TRANSIENT	IT_Bus::FaultCategory::TRANSIENT

# Mapping from Fault Categories

## Overview

When a fault (that is, a built-in exception) is returned from an Artix server to a CORBA client, Artix automatically converts the fault category to a CORBA system exception.

## Map from CORBA system exceptions to fault categories

Table 6 shows how each of the Artix fault categories map to major CORBA system exceptions.

**Table 6:** *Map from CORBA System Exceptions to Fault Categories*

Fault Category	CORBA System Exception
IT_Bus::FaultCategory::BAD_OPERATION	CORBA::BAD_OPERATION
IT_Bus::FaultCategory::CONNECTION_FAILURE	CORBA::COMM_FAILURE
IT_Bus::FaultCategory::INTERNAL	CORBA::INTERNAL
IT_Bus::FaultCategory::INVALID_REFERENCE	CORBA::INV_OBJREF
IT_Bus::FaultCategory::LICENSE	CORBA::NO_IMPLEMENT
IT_Bus::FaultCategory::MARSHAL_ERROR	CORBA::MARSHAL
IT_Bus::FaultCategory::MEMORY	CORBA::NO_MEMORY
IT_Bus::FaultCategory::NO_PERMISSION	CORBA::NO_PERMISSION
IT_Bus::FaultCategory::NOT_EXIST	CORBA::OBJECT_NOT_EXIST
IT_Bus::FaultCategory::NOT_IMPLEMENTED	CORBA::NO_IMPLEMENT
IT_Bus::FaultCategory::NOT_UNDERSTOOD	CORBA::BAD_PARAM
IT_Bus::FaultCategory::TIMEOUT	CORBA::TIMEOUT
IT_Bus::FaultCategory::TRANSIENT	CORBA::TRANSIENT
IT_Bus::FaultCategory::UNKNOWN	CORBA::INITIALIZE
IT_Bus::FaultCategory::VERSION_ERROR	CORBA::BAD_PARAM



---

# Mapping of Completion Status

---

## Overview

The CORBA completion status flag and the Artix fault completion status flag have exactly the same semantics and are thus effectively equivalent. In other words, a `YES` completion status implies that the remote operation completed its work; a `NO` completion status implies that the remote operation was never called; and a `MAYBE` completion status implies that it is impossible to say whether or not the remote operation completed its work.

---

## Completion status mapping

[Table 7](#) shows the mapping between CORBA completion status values and fault completion status values.

**Table 7:** *Completion Status Mapping*

CORBA Completion Status	Fault Completion Status
<code>CORBA::COMPLETED_YES</code>	<code>IT_Bus::FaultCompletionStatus::YES</code>
<code>CORBA::COMPLETED_NO</code>	<code>IT_Bus::FaultCompletionStatus::NO</code>
<code>CORBA::COMPLETED_MAYBE</code>	<code>IT_Bus::FaultCompletionStatus::MAYBE</code>



# Index

## A

- Address specification
  - CORBA 216
- anonymous types
  - avoiding 163
- architecture, Artix overview 18
- attributes
  - mapping 161

## B

- binding:client\_binding\_list configuration variable 37
- bindings 19
- boolean 143
- bounded sequences 129

## C

- char 143
- checked facets 152
- complex types
  - deriving 167
  - nesting 163
- containers 20
- CORBA
  - enum type 120
  - exception type 132
  - sequence type 128
  - struct type 122, 124
  - typedef 135
  - union type 130
- corba:address 216
- corba:address element 33
- corba:policy 217
- CORBA bindings
  - generating 32
- CORBA endpoints
  - generating 33
- CORBA ports
  - generating 33

## D

- derivation
  - complex type from complex type 167

- double 143

## E

- embedded router 24
- ENTITIES 156
- ENTITY 156
- enumeration facet 152
- enum type 120
- exception handling
  - CORBA mapping 132
- exception type 132

## F

- facets 152
  - checked 152
- fixed 144
- fixed ports
  - host 106
  - IIOP/TLS listen\_addr 106
  - IIOP/TLS port 106
- float 143
- fractionDigits facet 152

## G

- get\_discriminator() 126
- get\_discriminator\_as\_uint() 126
- giop plug-in 37
- GIOP Snoop 199

## I

- IDL
  - bounded sequences 129
  - enum type 120
  - exception type 132
  - object references 137
  - oneway operations 139
  - sequence type 128
  - struct type 122, 124
  - typedef 135
  - union type 130
- IDL attributes
  - mapping to C++ 139

- IDL interfaces
  - mapping to C++ 136
- IDL modules
  - mapping to C++ 136
- IDL operations
  - mapping to C++ 138
  - parameter order 139
  - return value 139
- IDL readonly attribute 140
- IDREF 156
- IDREFS 156
- IIOPTLS
  - host 106
- IIOPTLS listen\_addr 106
- IIOPTLS port 106
- iiop plug-in 37
- iiop\_profile plug-in 37
- inheritance relationships
  - between complex types 167
- inout parameters 139
- in parameters 139
- IOR specification 216
- IT\_Bus::Boolean 173
- it\_container command 20

**J**

- JAX-RPC mapping 19

**L**

- length facet 152
- LocateReply 204
- LocateRequest 204
- long 143
- long long 143

**M**

- mapping
  - IDL attributes 139
  - IDL interfaces 136
  - IDL modules 136
  - IDL operations 138
- maxExclusive facet 152
- maxInclusive facet 152
- maxLength facet 152
- maxOccurs 170, 174
- minExclusive facet 152
- minInclusive facet 152
- minLength facet 152

- minOccurs 174

**N**

- nesting complex types 163
- nillable types
  - syntax 176
- NOTATION 156

**O**

- object references
  - mapping to C++ 137
- occurrence constraints
  - overview of 174
- octet 143
- oneway operations
  - in IDL 139
- orb\_plugins 201
- out parameters 139

**P**

- parameters
  - in IDL-to-C++ mapping 139
- pattern facet 152
- plugins:giop\_snoop:filename 203
- plugins:giop\_snoop:rolling\_file 203
- plugins:giop\_snoop:shlib\_name 201
- plugins:giop\_snoop:verbosity 202
- ports 19
  - activating 36
- port types 18
- protocol bridge 20

**R**

- references
  - CORBA mapping 137
- Reply 204
- Request 204
- router plug-in 20
- routers 20
- routes, configuring 21

**S**

- sequence complex types
  - and arrays 170
- sequence type 128
- servant objects 19
- servants

- registering 36
- short 143
- Specifying POA policies 217
- standalone router 23, 28
  - CORBA-to-SOAP 40
- string 143, 144
- struct type 122, 124
- stub code 19
- stub files 37

## T

- TimeBase::UtcT 144
- totalDigits facet 152
- transports 19
- typedef 135

## U

- unions
  - logical description 124
- union type 130
- unsigned long 143
- unsigned long long 143
- unsigned short 143

## W

- Web Services Definition Language 18
- whiteSpace facet 152
- wildcarding types 173
- WSDL
  - attributes 161
- WSDL contract 18
- WSDL facets 152
- WSDL faults 132
- wsdltocorba command
  - generating a CORBA binding 32
  - generating IDL 34
- wsdltocpp command 19
- WSDL-to-IDL conversion 32
- wsdltojava command 19
- wsdltoservice command 34
- ws\_orb plug-in 37

## X

- XML schema
  - wildcarding types 173
- xsd:ENTITIES 156
- xsd:ENTITY 156
- xsd:IDREF 156
- xsd:IDREFS 156
- xsd:NOTATION 156

