

A Mentoring-Based Approach to JBoss Adoption

Revolutionizing La Petite Academy's Enterprise Utilizing SOA, the JEMS Platform, and Amentra's Signature Mentoring Approach

Agenda

- Introduction
- The Challenges of Legacy Modernization
- Amentra's Mentoring Approach
- Case Study: La Petite Academy
- Conclusion

La Petite Academy - Background

- Nation's largest privately held early childhood educator
- Operations in 35+ states
- Over 600 branches (academies)

Business Challenges

- Cost Justification
- Regulatory Risk
- Shortcomings of Legacy Infrastructure
- Product Selection Risk
- Implementation Risk

Business Challenges (cont.)

- Potential Staff Turnover / Loss of Business Knowledge
- Critical External Leverage
- Failure to Realize Productivity Gains
- Failure to Realize Integration Savings
- Increased Total Cost of Ownership

Technical Challenges

- Creation of new distributed infrastructure to support near-real-time data transfer from hundreds of locations
- Integration with existing enterprise reporting environment
- Ability to support modification of complex staffing model by business users

Business Goals

- Reduce extraneous labor costs
- Perfect regulatory compliance
- Real-time operational visibility in 600+ academies

7



Technical Drivers

- Preserve flexibility through proper use of standards
- Build infrastructure to support operations and decision support
- Proactively manage TCO
 - ✓ Control hidden costs

8



A Service-Oriented Approach

- Created stateless, coarse-grained business services
- Utilized enterprise service bus to provide location-agnostic discovery and invocation of services

9



Risks / Costs

- Methodology mismatch
- Skillset mismatch
- Change management / staff turnover
- Potential reduced productivity in new environment

10



Approach

- Agile Methodology
- Signature Mentoring Model
- Favor Buy Over Build

11



Mentoring Explained

- Staff Skill Set Evaluation
- Best Practices Opportunity Analysis
- Mentoring Topic Customization
- Delivery Process Planning
- Periodic Review and Adjustment

12



Physical Architecture (Prior)

13



Physical Architecture (Current)

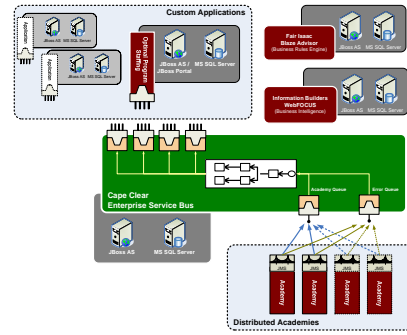

14



Logical Architecture (Current)

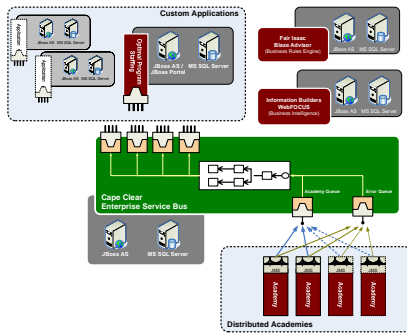

15



New Business Environment

- Reduction in Labor Costs
- Increased Regulatory Compliance
- Greatly Increased Operational Visibility
- Platform for Future Efforts

16



Conclusions

- Any major technical migration creates risk as well as opportunity
- SOA adoption poses unique challenges
- Amentra's mentoring model can address these risks and challenges

17

