



movistar



hola

Mateus Bartz

(@mateus_bartz)

Internet and IT professional with +10 years managing a broad range of technologies in large-scale and mission-critical environments. Now working in Telefónica as “Tools master”.

Automation, Photos and Programing are my current passion.

My motto: If moves, measure it. If not move as you want, automate it!

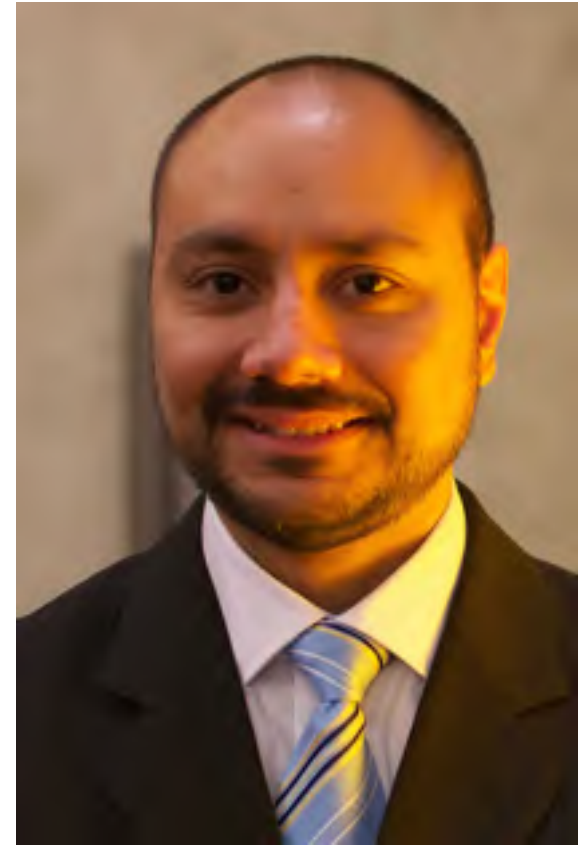

Who are we?



Almudena Vivanco

(@MrsDaehin)

From .net developer to tester. 10 years of experience as performance engineer. Now working in Telefónica I +D as “Performance Jedi”.

Active member of the web performance community in Barcelona.

Gaming, Music and Maths are my passion

My motto: Games don't cause violence, Lag does!



Who are we?

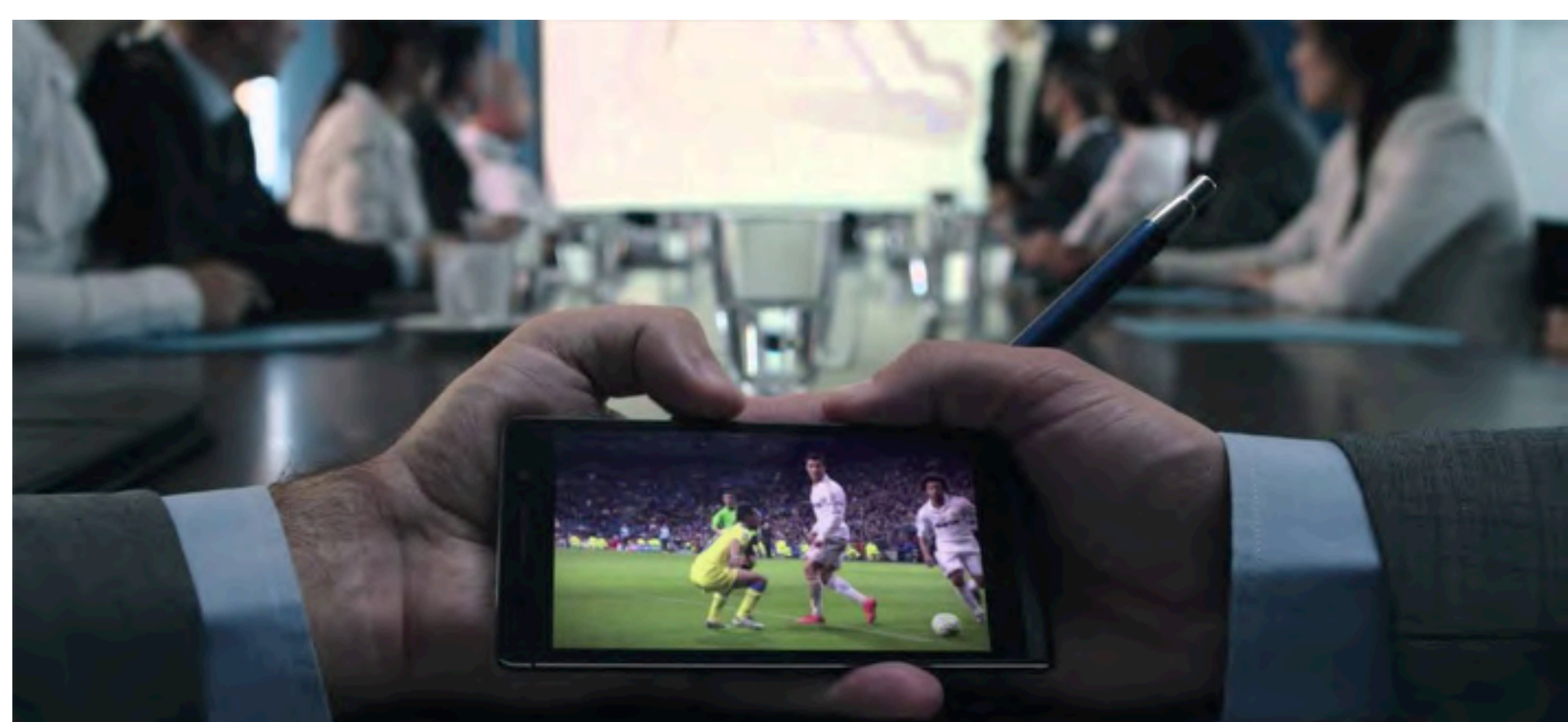

Guide to survive a World Wide Event

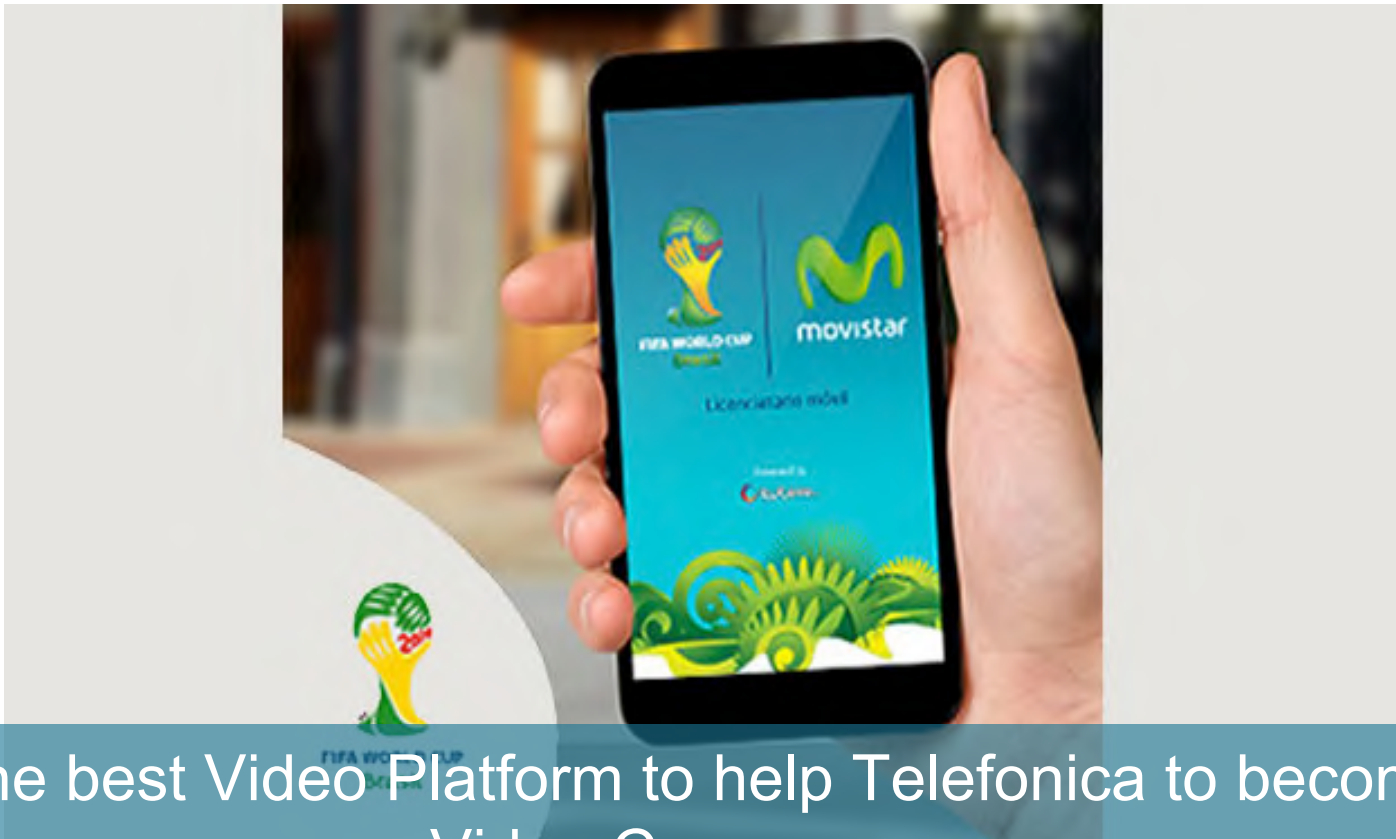

Build the best Video Platform to help Telefonica to become a Video Company

The Challenge



- **PASSION** - If it was OK, they will be back
- **DON'T MISS THE TARGET** – The audience go away
- **WILL START WITHOUT YOU** - The soccer game will start at the date/time



The Users





The Passion



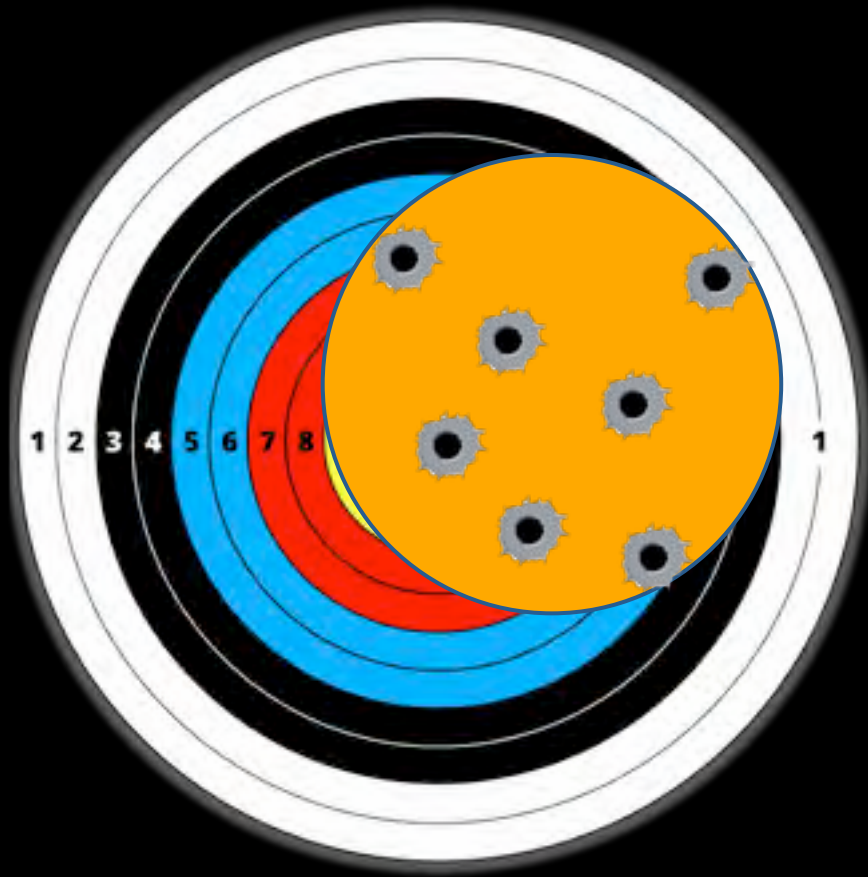

- Do you know what you are missing?
- Know how to act?
- Have the relevant info?

Don't miss the target



The Team



Our Goal



Scalability



usuarios

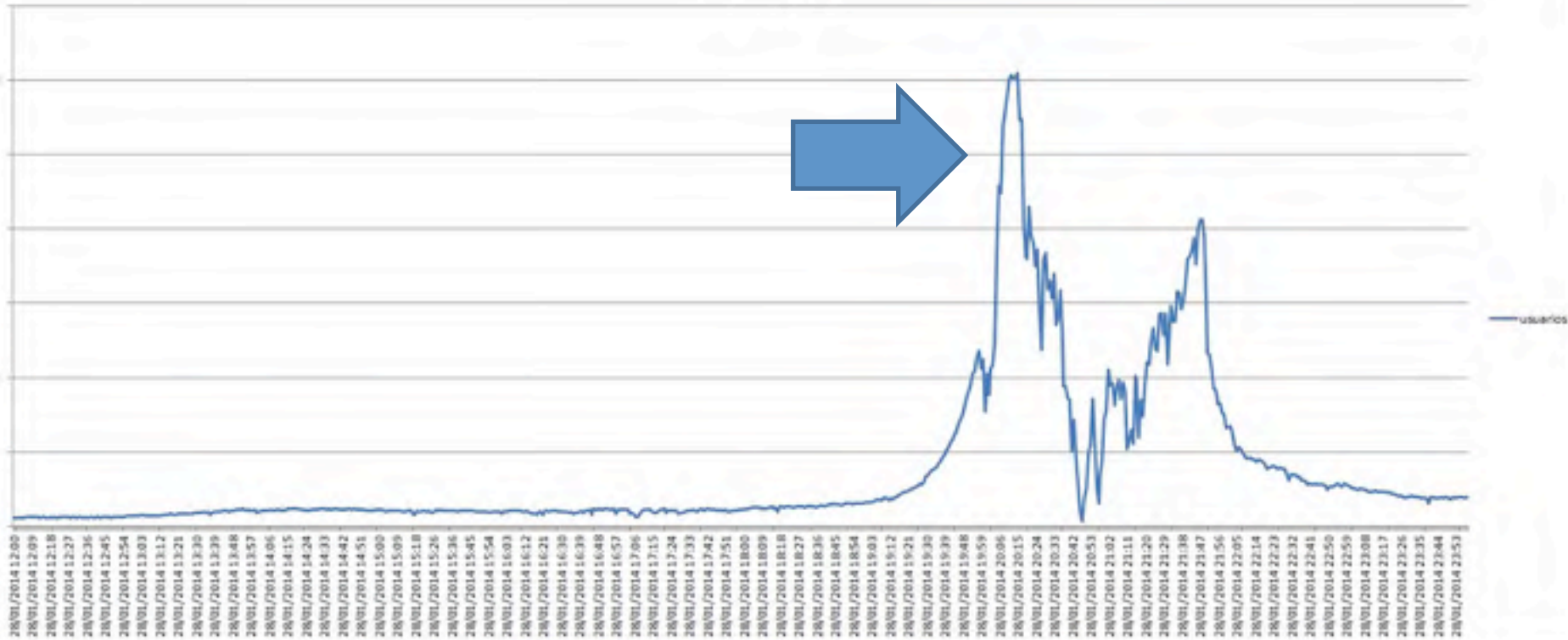

The Behaviour

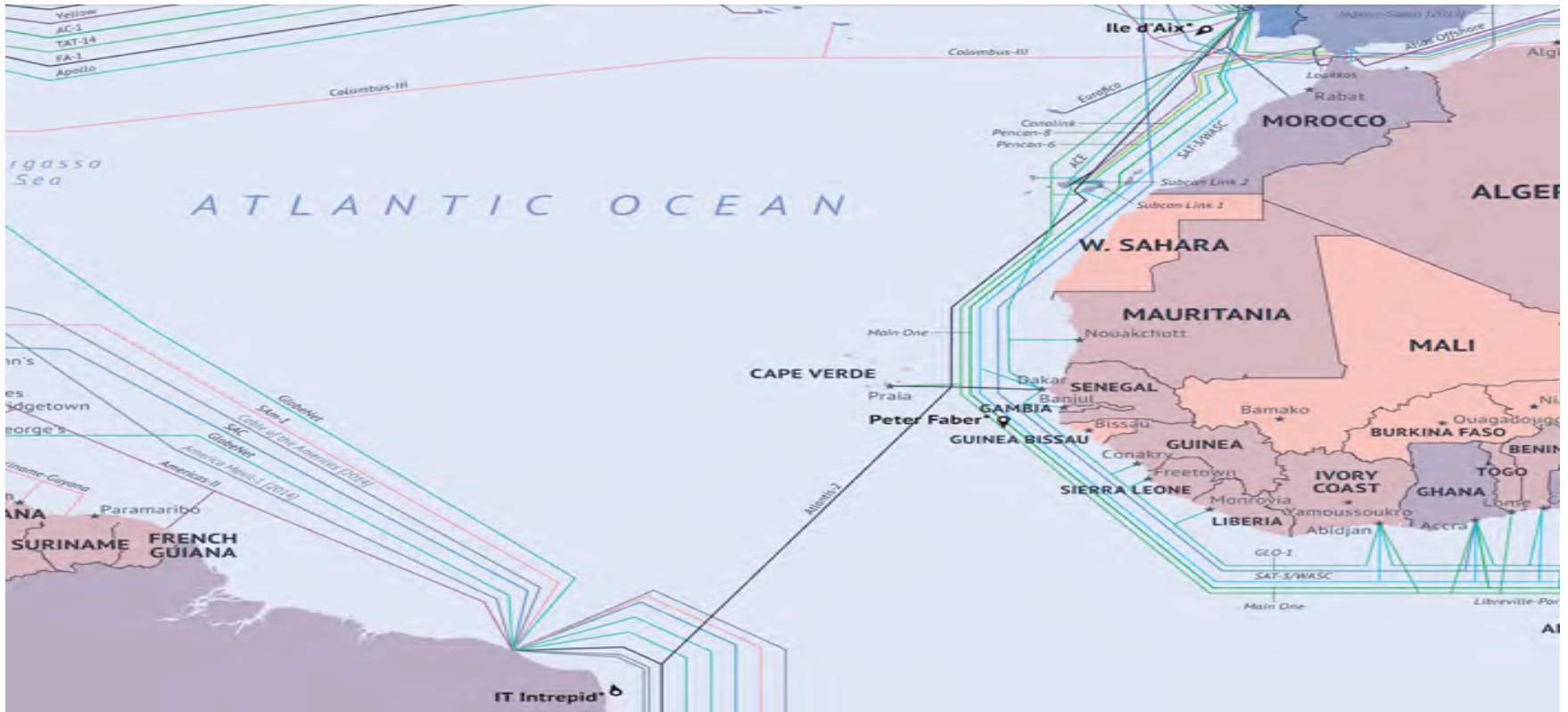

Spain - Brazil- Argentina





And MANY more

Many Devices





Change of Strategy

 SUPPORT

 ENGINEER

 RECON

 ASSAULT



Global Video Platform Squads



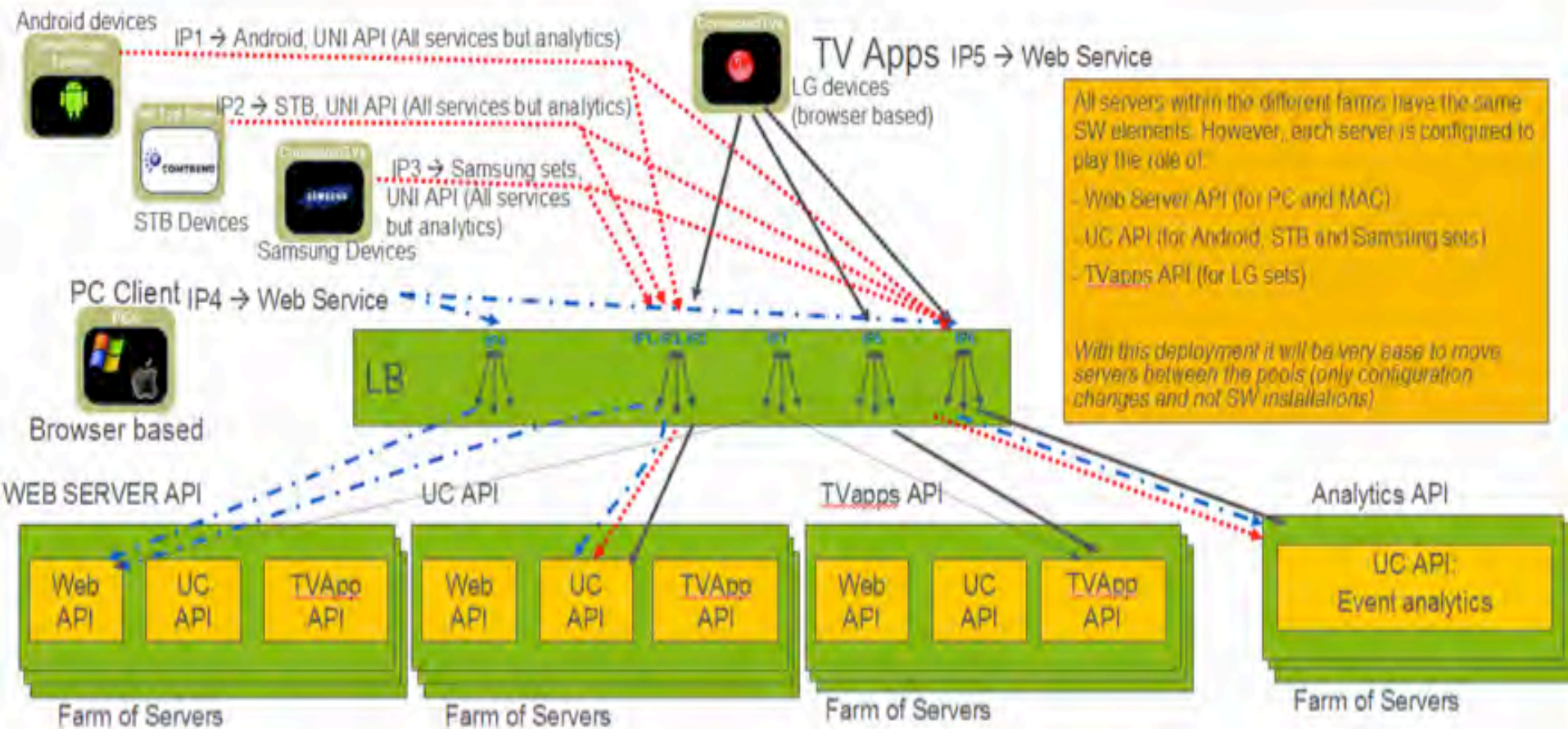

Deployment



PREPROD Environment

Automated Tests in .NET

Stable Environment

Continuous ... wait ... what?

TEST IN PRODUCTION?

FINE BY ME

TROLL.ME

Stable Testing Environment





Thumbbox



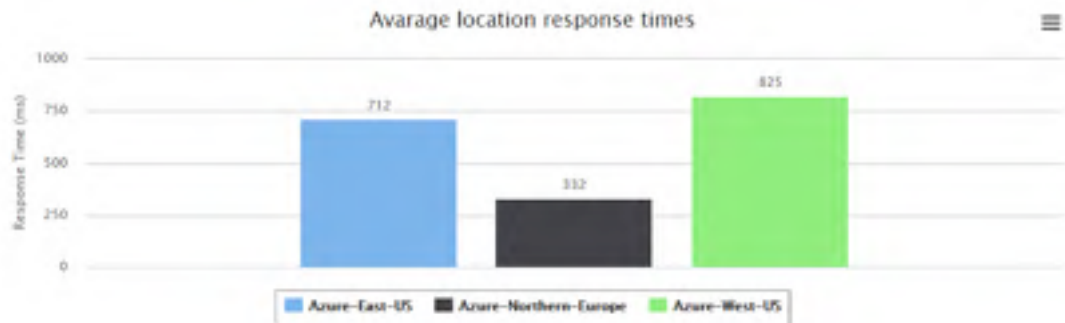

TEST	"Pre" time	"Post" time	Improvement
OTT / Spanish client: first time	523 ms	244 ms	279 ms (53%)
OTT / Spanish client: second time	531 ms	210 ms	321 ms (60%)
OTT / Spanish client: third time	529 ms	237 ms	292 ms (55%)
OTT / Brazilian client: first time	4,7 seg	1,5 seg	3,2 seg (67%)
OTT / Brazilian client: second time	4,6 seg	1,9 seg	2,7 seg (59%)
OTT / Brazilian client: third time	4,5 seg	1,7 seg	2,8 seg (62%)



Telefónica CDN
Your content. No limits.



In House CDN



Old Approach

- Monitoring resolution **5 minutes**
- **11 tools** to monitor performance

New Approach

- Monitoring resolution **15 seconds**
- Centralized in **1 tool** to monitor performance

Don't miss the target

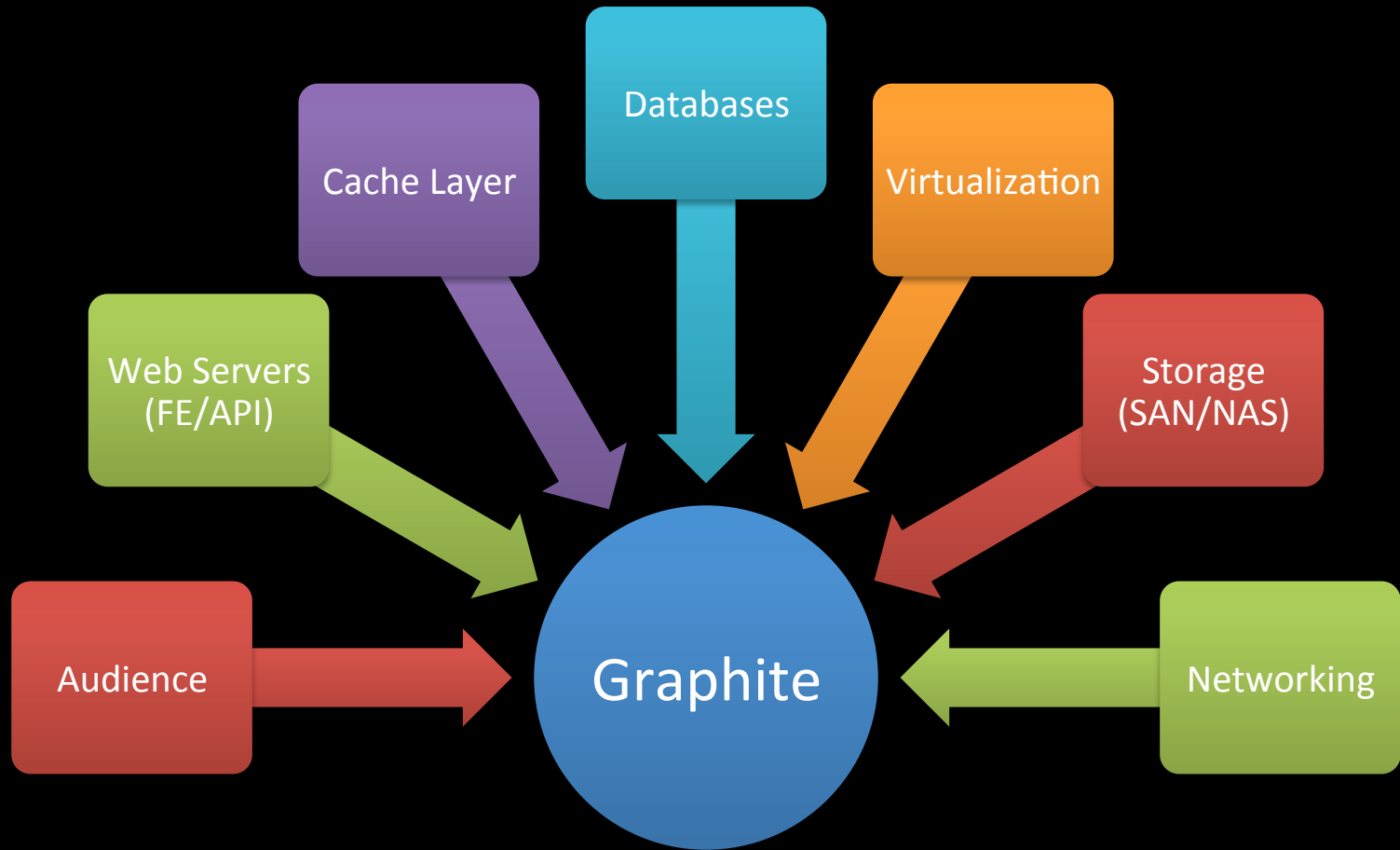

Don't miss the target



Don't miss the target



What is graphite?

- A highly scalable real-time graphing system
- Comprise of 3 projects
 - Carbon (Collect and record metrics)
 - Whisper (Storage mechanism)
 - Graphite-Web (web GUI)
- Start here:
 - <http://graphite.readthedocs.org/>
 - <https://github.com/graphite-project/graphite-web>

Don't miss the target



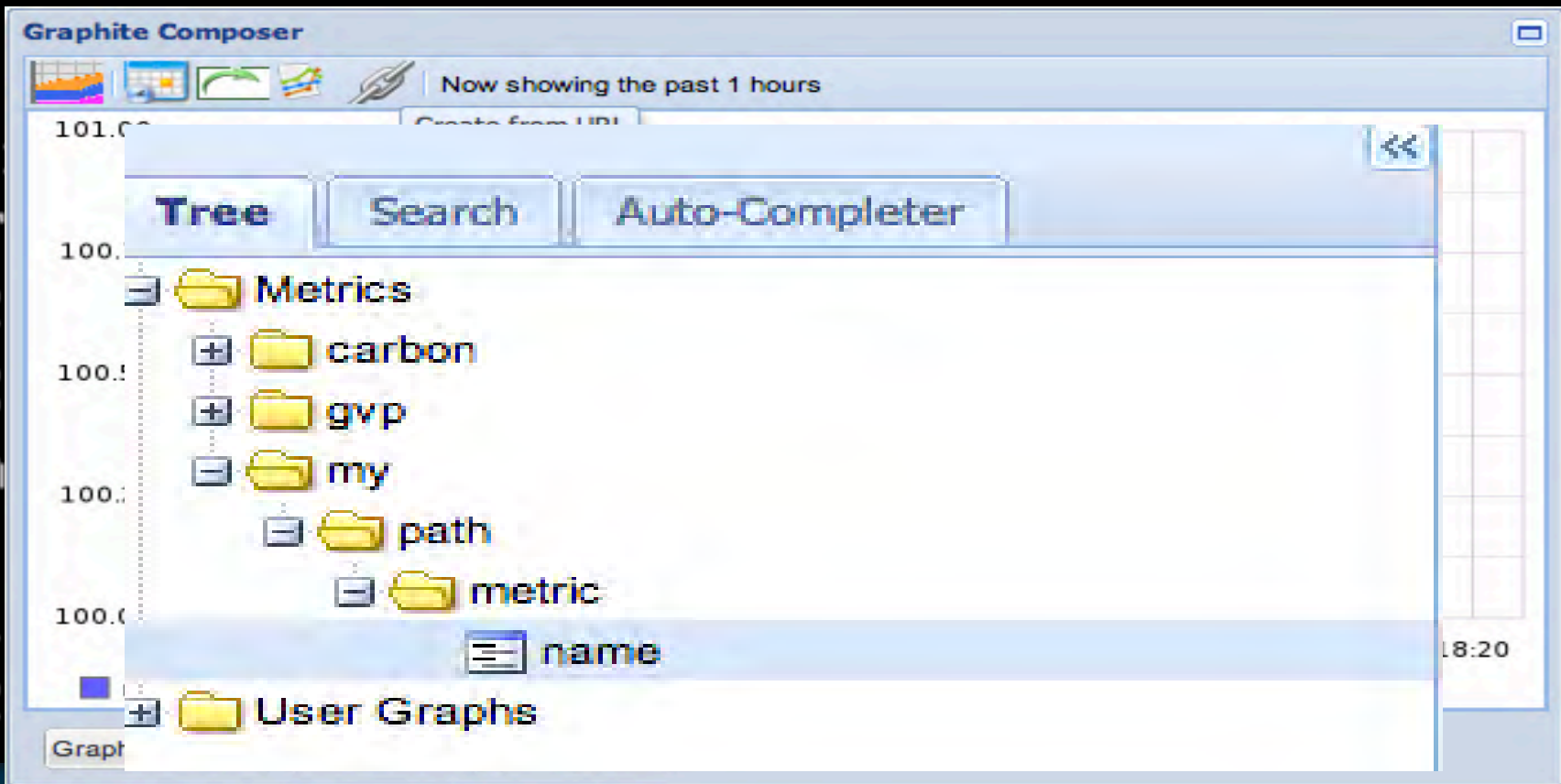

Don't miss the target

Introducing: The Soccer Game

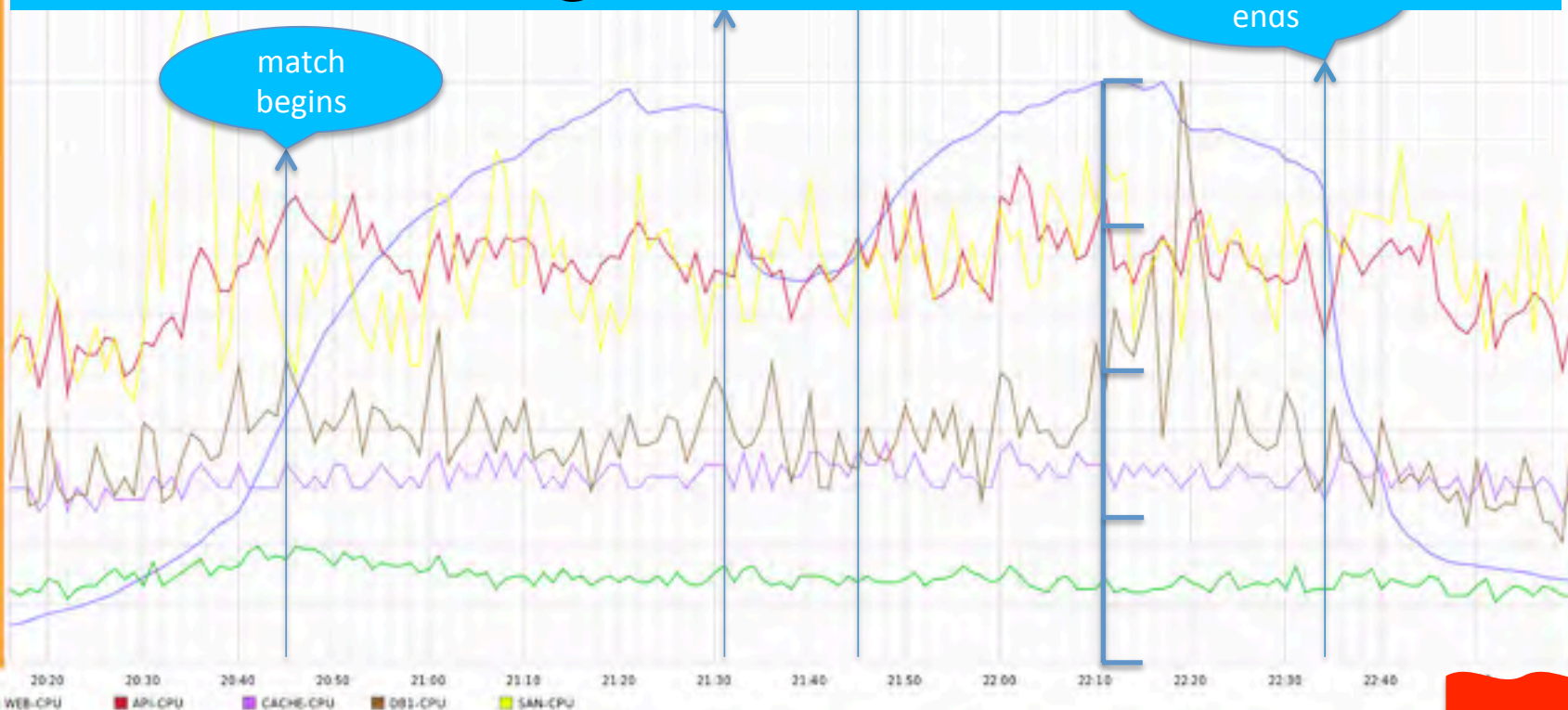

Don't miss the target

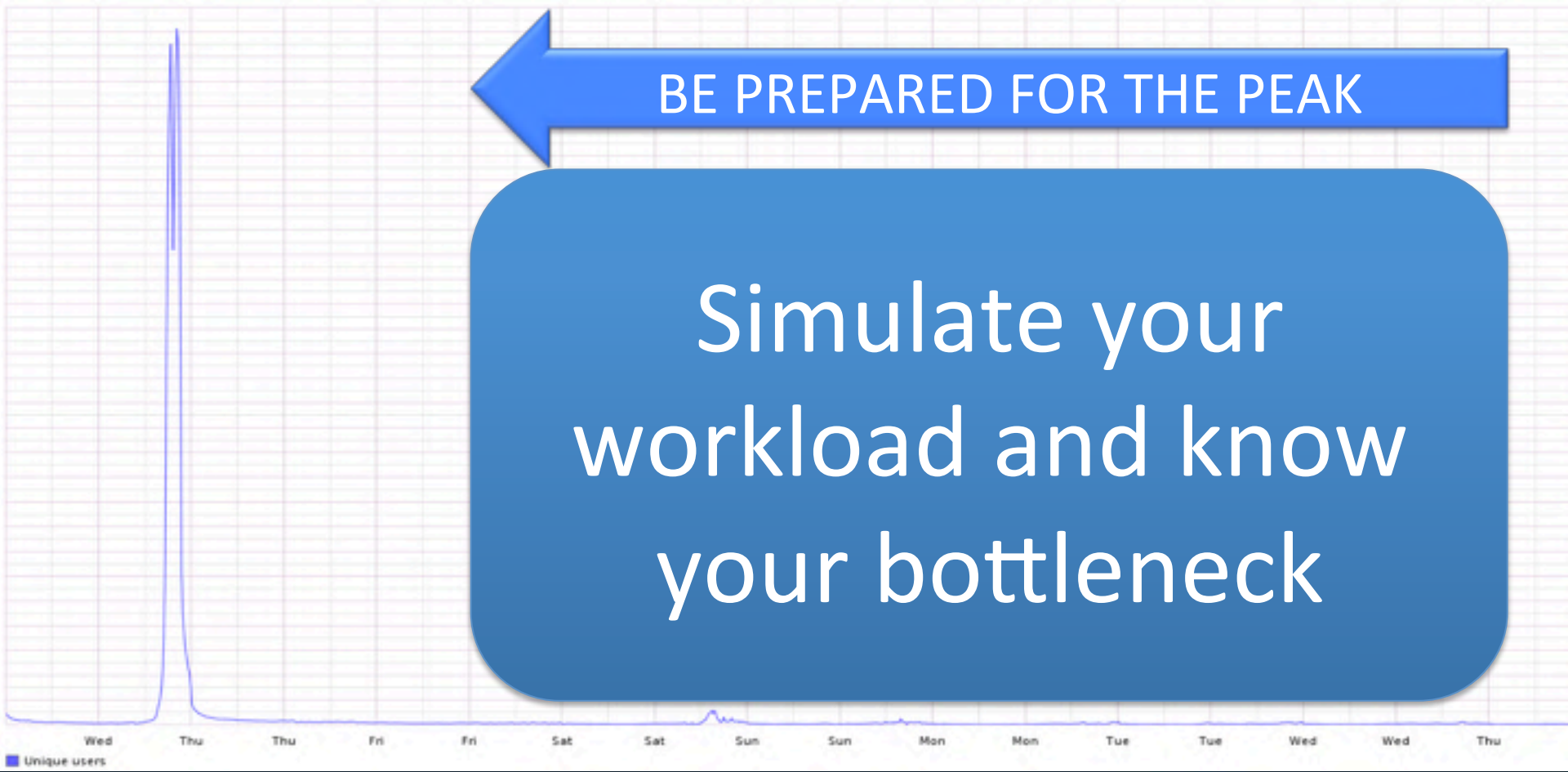

BE PREPARED FOR THE PEAK

Simulate your workload and know your bottleneck

Don't miss the target





bad things
solve it !!!!

Don't miss the target



If you need
different output

Start adding a
feedback (B)

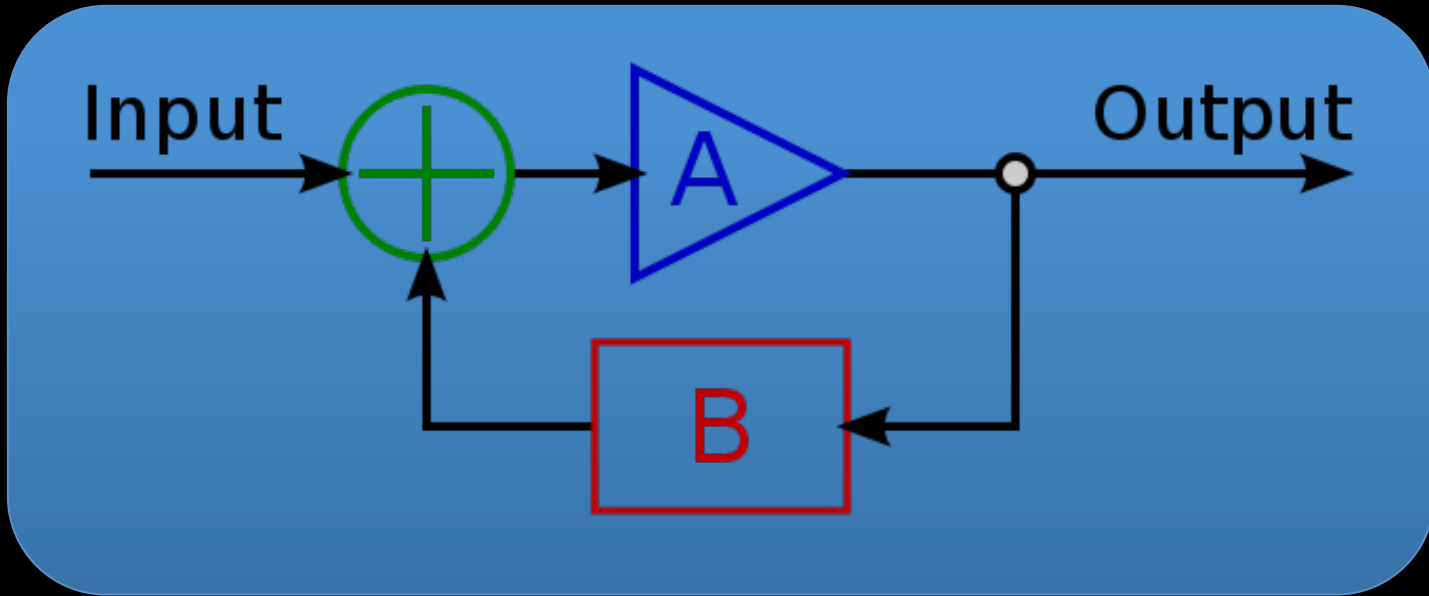

Don't miss the target

Don't do queries
with full tables scans

Show and give
access

```
SELECT
  OBJECT_NAME(S.[OBJECT_ID]) AS [OBJECT NAME],
  I.[NAME] AS [INDEX NAME],
  USER_SEEKS,
  USER_SCANS,
  USER_LOOKUPS,
  USER_UPDATES
FROM
  SYS.DM_DB_INDEX_USAGE_STATS AS S
  INNER JOIN SYS.INDEXES AS I
  ON I.[OBJECT_ID] = S.[OBJECT_ID]
  AND I.INDEX_ID = S.INDEX_ID
```

Don't miss the target

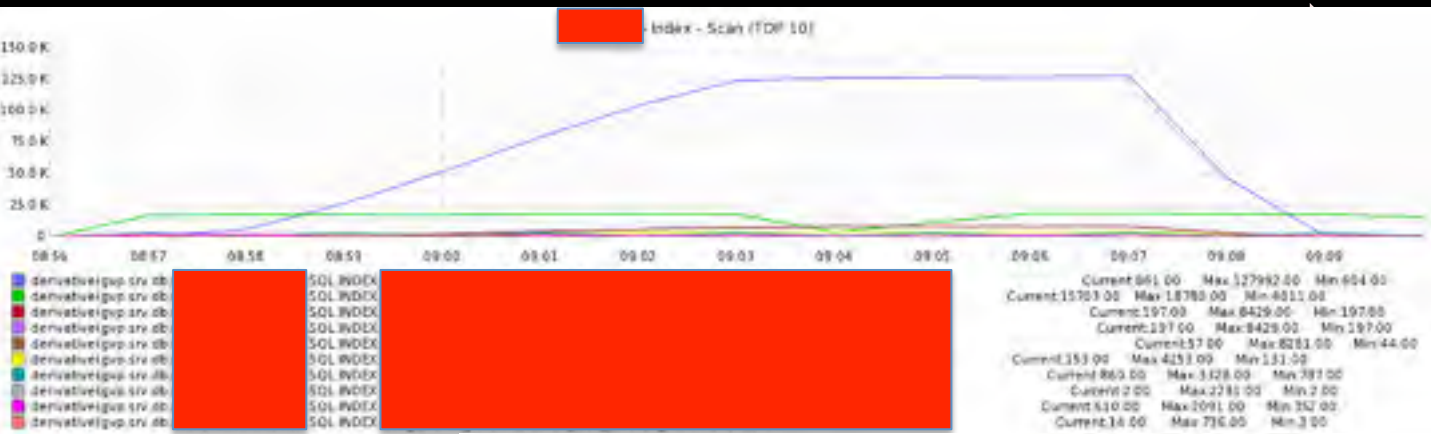

Index

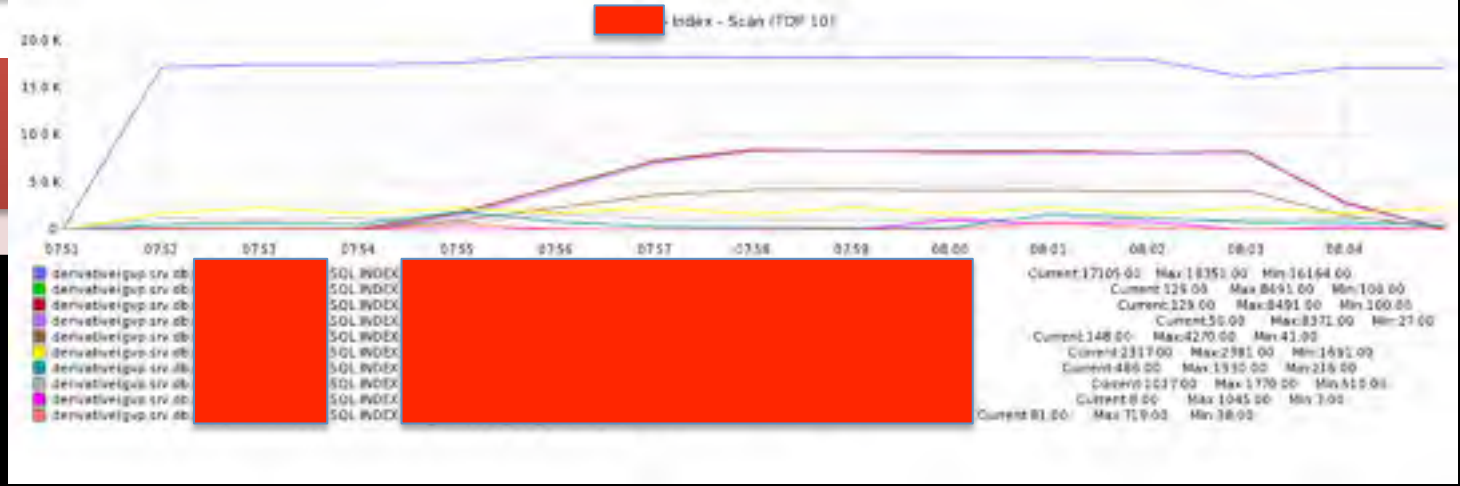

Don't miss the target



Know what are you doing!!!



Don't miss the target



The soccer game will start
if you are ready or not.

Get your team ready. They have
to know what to do.

It will start without you





It will start without you



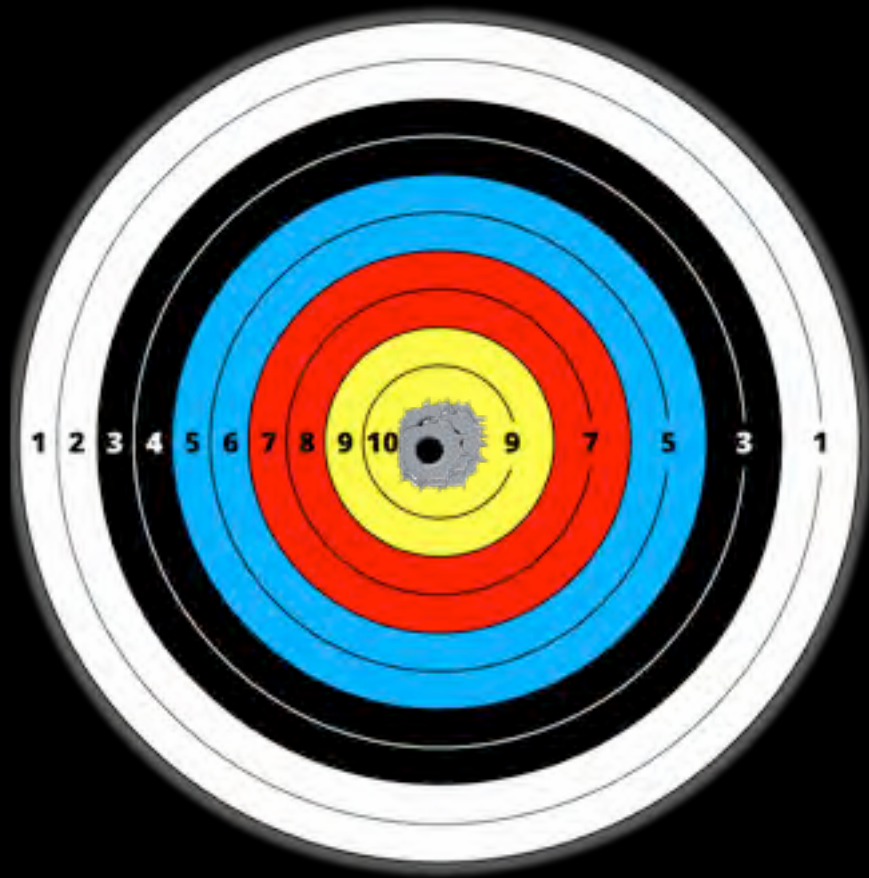

It will start without you





Questions



Wherever. Whenever. However.
BE MORE.

BE MORE.

Thank you!!!